

Recessed Electric Over Door Heater



Turnbull & Scott™
Trusted.

RDH | Recessed Electric Over Door Heater



PRODUCT DESCRIPTION

Our over door heaters provide a warm welcome for those entering by warming the air around the entrance area to create a pleasant room environment.

A powerful fan heater designed to be concealed in a ceiling void or bulkhead above a door, it is ideal for installation in shops, retail outlets, offices, entrance halls and workshops.

The purpose designed mounting arrangement allows the recessed over door heater to be fitted within the ceiling space or over door bulkhead provided adequate provision is made for the incoming airflow.

FEATURES

- 3kW, 4.5kW, 6kW and 9kW units available
- Mounting suitable for ceiling void or bulkhead installation
- Over temperature cut-out with power off reset
- Can be mounted from above or below the ceiling
- Complete with grille frame for a neat installation
- Selection of heat and fan only with remote switch unit (included)
- Outlet grille and frame in white powder coated finish (RAL9003)
- Other RAL colour powder coating finishes available on request subject to quantities ordered



RDH Electric Recessed Over Door Heater



Remote Switch Unit

RDH | Recessed Electric Over Door Heater

CONTROL

Heat output and fan only control is achieved with the included remote switch unit.

RDH-3000 Fan only with 1kW, 2kW and 3kW.

RDH-4500 Fan only with 2.25kW and 4.5kW.

RDH-6000 Fan only with 3kW and 6kW.

RDH-9000 Fan only with 4.5kW and 9kW.

OTHER CONTROL OPTIONS

The RDH-3000 and RDH-4500 can be controlled by a remote thermostat and/or time controller of suitable rating, connected in the main supply line (not included).

The RDH-6000 and RDH-9000 can be controlled by a remote thermostat and/or time controller via the heater's control circuit (not included).

TECHNICAL SPECIFICATON

Product Code	Control Type	kW	Volts	Heater			Grille			Weight kg
				Length mm	Height mm	Depth mm	Length mm	Height mm	Depth mm	
RDH-3000	Remote switch included	3	230	570	210	120	625	145	120	6
RHD-4500	Remote switch included	4.5	230	570	210	120	625	145	120	6
RDH-6000	Remote switch included	6	230	800	210	120	855	145	120	13
RDH-9000	Remote switch included	9	230/400	1170	210	120	1225	145	120	13

RDH | Recessed Electric Over Door Heater

INSTALLATION

The heaters are designed to take their input air from the ceiling void. It is therefore imperative that a suitably sized inlet grille is provided within the ceiling or enclosure. The minimum clearance to the top inlet grille is 20mm, to the back 30mm and to the front inlet grille 100mm. If one inlet grille is at its minimum dimension the other must have an unrestricted airflow.

For optimum effect the heater should be mounted as close as possible to the top of the doorway. The maximum recommended mounting height is 2.3m for 3kW and 2.8m for 4.5kW, 6kW and 9kW units.

It is recommended a frame is provided around the ceiling opening. The adjustable brackets then allow fixing to the top of this frame or to the face of the ceiling. Alternatively, holes are provided in the top of heater for drop rod fixings.

The grille frame is fixed directly to the ceiling to provide a decorative finish.

3kW, 4.5kW and 6kW units are only suitable for connection to a 230V single phase power supply. The 9kW is suitable for both a 230V single phase or 400V three phase and neutral supply.

Connection should be made to a suitably fused power supply via the remote switch unit. 4.5kW, 6kW and 9kW must be connected directly to the power distribution board. Connection should be via a 2 pole switched connection unit having a contact separation of at least 3mm in all poles.

All electrical connections should be made by a suitably qualified person in accordance with the latest edition of the IEE Requirements for Electrical Installation (BS 7671:2008).

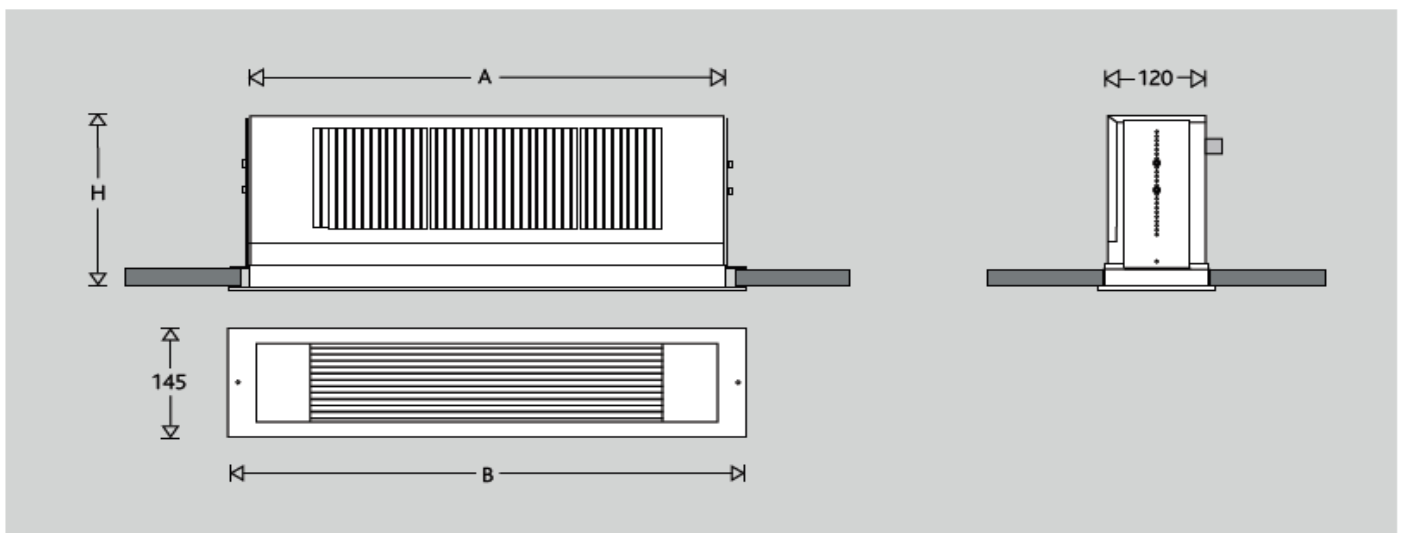



Burnfoot Industrial Estate
Roxburghshire,
Scotland, TD9 8SL

www.turnbull-scott.co.uk

01450 372 103