

DANTHERM GROUP



PROFESSIONAL INSTALLED
CLIMATE SOLUTIONS

HEAT PUMPS, HEATERS, DEHUMIDIFIERS, EVAPORATIVE COOLERS,
ELECTRONIC COOLING AND VENTILATION

Dantherm[®]
CLIMATE SOLUTIONS

TROTEC
CLIMATE SOLUTIONS

MASTER[®]
CLIMATE SOLUTIONS



About the Dantherm Group

Dantherm Group is a European leader in portable and installed climate control solutions for a wide range of industries and uses. Based on the heritage of the variety of brands we own, our climate control experts build and manufacture hundreds of thousands of exceptional heating, cooling, dehumidification, air cleaning and ventilation units in our own factories in Europe every year.

All of them are designed to create healthy and comfortable climate surroundings in a sustainable, energy-efficient and cost-effective way.

Why partner with us

- ✓ European design quality
- ✓ Experts in climate control
- ✓ Extensive range of solutions



INDEX

Heating solutions: Swimming pool heat pumps, industrial heaters	4
Drying and humidity control solutions: Swimming pool climate control, industrial drying and air handling	33
Cooling solutions: Evaporate cooling systems	147
Cooling and ventilation solutions: For data centres, telecom cabinets and industry	159
Ventilation solutions: For residential buildings	171



Discover our
climate solutions
danthermgroup.com



DANTHERM GROUP



PROFESSIONAL INSTALLED
HEATING SOLUTIONS

FOR SWIMMING POOLS, BUILDINGS, COMMERCIAL SPACES, INDUSTRY AND PRODUCTION

Dantherm[®]
CLIMATE SOLUTIONS

MASTER[®]
CLIMATE SOLUTIONS

I-PAC PRO



I-PAC PRO

The I-PAC PRO range is the next generation of high-performance inverter heat pumps that are designed specifically for energy-efficient heating and cooling of swimming pools. Engineered with cutting-edge technology and eco-friendly components, the heat pumps offer a reliable and energy-efficient solution for a wide range of pool applications, including outdoor and indoor pools, hotel and spa pools, therapy pools, health clubs, and wellness centers.

The units combine advanced features with user-friendly controls, making them an ideal choice for both commercial and private settings. With their quiet operation, robust performance, and remote monitoring capabilities, they provide unparalleled convenience, performance, and comfort all year round.

- Inverter heat pumps – deliver enhanced performance and energy savings
- Expanded range – includes high-capacity single- and three-phase models (I-PAC PRO 28A and 36B)
- Eco-friendly R32 refrigerant – environmentally responsible and highly efficient
- Remote control/monitoring – handle device control, firmware updates and fault diagnostics over the air
- Titanium condenser – provides corrosion resistance and durability in pool environments
- Touchscreen user interface – integrated controller with real-time data and easy operation
- Multi-function operation – choose from heating, cooling, or a combination of both
- Built-in Wi-Fi module – control your heat pump remotely via the Pooltherm App
- Operating range of -20°C to +43°C – reliable year-round operation in extreme temperatures
- New silence mode – reduces noise levels, perfect for noise-sensitive locations
- Standard supply – winter cover, anti-vibration mounts, condensate drainage kit and water union connectors
- Optional – wired remote control panel with 10m cable

Product dimensions

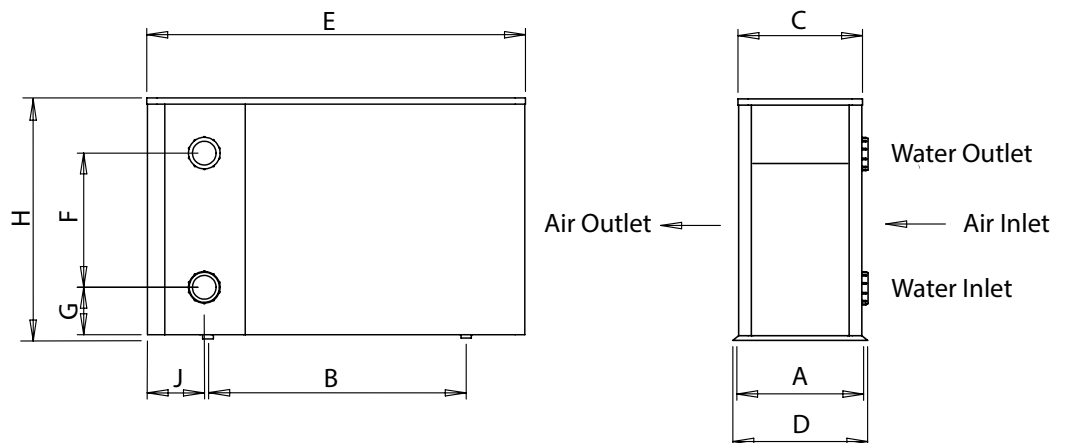

Model	Units	A	B	C	D	E	F	G	H	J
10A	mm	402	574	390	427	946	340	75	660	108
16A		402	824	390	427	1,195	470	75	760	108
22A		511	700	495	536	1,071	550	75	953	122
22B		511	700	495	536	1,071	550	75	953	122
28A		511	891	495	536	1,264	550	75	954	133
28B		511	891	495	536	1,264	550	75	954	133
36B		511	991	495	536	1,364	670	75	954	133

I-PAC PRO

Specifications	Units	10A	16A	22A	22B	28A	28B	36B
Performance – air 27°C 80% RH. water 27°C								
Heating capacity (Turbo mode)	kW	14.5	22.5	27	27	32.5	32.5	40.5
Heating capacity (Perfect mode)	kW	11.6	18	21.6	21.6	26	26	32.5
COP range (Perfect mode)		7.5 ~ 20.1	7.3 ~ 20.4	7.4 ~ 20.2	7.3 ~ 20.1	7.2 ~ 20	7.3 ~ 19.7	7.3 ~ 20
COP 50% speed (Perfect mode)		14.8	15.2	15	14.9	14.7	14.6	14.7
Performance – air 15°C 70% RH. water 26°C								
Heating capacity (Turbo mode)	kW	9.6	15	18.5	18.5	22.7	22.7	29
Heating capacity (Perfect mode)		7.8	12	15	15	18.8	18.8	23.5
COP range (Perfect mode)		5.2 ~ 8.6	5.3 ~ 9.0	5.2 ~ 8.9	5.3 ~ 8.6	5.4 ~ 8.1	5.3 ~ 8.2	5.2 ~ 8.0
COP 50% speed (Perfect mode)		7.4	7.7	7.6	7.4	7.2	7.2	7.1
Performance – air 5°C 70% RH. water 10°C								
Heating capacity (Turbo mode)	kW	9.3	14.9	17.5	17.2	21.4	21.6	27.5
Performance – air -10°C 70% RH. water 23°C								
Heating capacity (Turbo mode)	kW	5.2	8.2	10.3	9.9	11.4	11.6	14.9
Performance – air 35°C 80% RH. water 28°C								
Cooling capacity	kW	6.7	11.9	13.5	13.5	15.4	15.4	20
Air temperature range	°C	-20°C to 43°C						
Water heating setting range	°C	18°C to 40°C						
Water cooling setting range	°C	5°C to 30°C						
Power supply	V / ~ / Hz	230/1ph/50	230/1ph/50	230/1ph/50	400/3ph/50	230/1ph/50	400/3ph/50	400/3ph/50
Rated input power	kw	0.22 ~ 1.85	0.34 ~ 2.83	0.43 ~ 3.56	0.42 ~ 3.49	0.50 ~ 4.20	0.51 ~ 4.28	0.67 ~ 5.58
Max input current	A	12.5	18.5	20.5	8	24	9.4	12.5
Waterflow	m ³ /h	3 ~ 4	6 ~ 9	8 ~ 10	8 ~ 10	10 ~ 12	10 ~ 12	12 ~ 18
Water connection		48.3mm or 50mm female						
Compressor		Inverter						
Condenser		Titanium						
R32 gas weight / CO ₂ equivalent		1.25 / 0.844	1.7 / 1.148	2.3 / 1.553	2.4 / 1.620	3 / 2.025	3 / 2.025	3.6 / 2.430
Sound level @10m	dB(A)	16.4 ~ 24.8	18.8 ~ 28.5	18.8 ~ 29.2	19.0 ~ 29.4	19.6 ~ 30.2	19.7 ~ 30.4	19.9 ~ 30.5
Dimensions (w x d x h)	mm	946 x 427 x 660	1,195 x 427 x 760	1,071 x 536 x 953	1,071 x 536 x 953	1,264 x 536 x 954	1,264 x 536 x 954	1,364 x 536 x 954
Net weight	kg	65	82	100	111	122	132	147

Swimming pool inverter heat pumps
CALOREX I-PAC 8-12-16-22



I-PAC 12

Inverter technology allows for efficient control of the pool temperature, and the I-PAC only uses what energy is needed when it is required. High efficiency with modulating step-less inverter compressor giving an average COP of 9.7.



- 2 x more efficient than on/off heat pumps
- R32 = 675 GWP, (Global Warming Potential)
- Inverter heat pump
- Power ratings from 9.5 to 25kW
- 9-11 dB(A) sound reduction compared to an equivalent on/off heat pump, with 'Whisper Mode'
- Operates in air temperatures of -5°C to 43°C
- Integrated controller with a touchscreen user interface
- Function settings for heating, cooling or heat/cool
- Soft start-up
- Aluminium alloy
- Built-in Wi-Fi module
- PoolTherm App
- Winter protection cover included

Dimensions (mm)

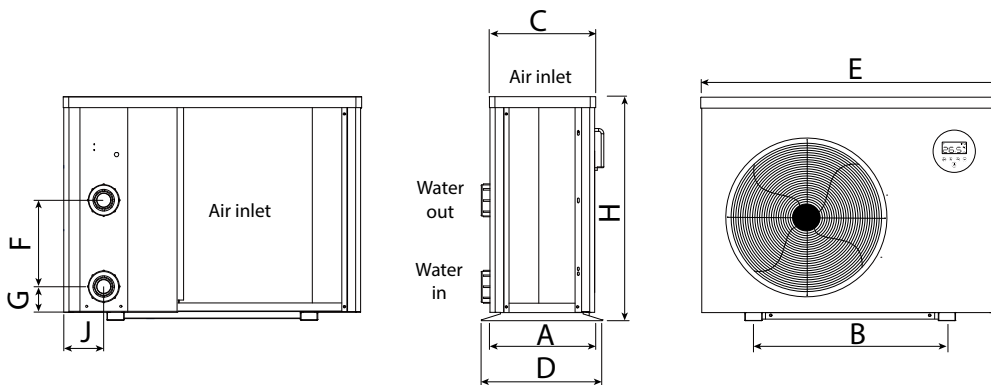

Model	A	B	C	D	E	F	G	H	J
I-PAC 8ALX	334	560	318	359	864	250	74	648	116
I-PAC 12ALX	334	560	318	359	864	290	74	648	116
I-PAC 16ALX	334	590	318	359	954	390	74	748	116
I-PAC 22ALX	404	720	388	429	1084	640	74	948	107

Swimming pool inverter heat pumps

CALOREX I-PAC 8-12-16-22

Included in the box



Rubber feet
(kit of 4) 1005526



Drainage kit 1005558



Water union
connectors 2 x 1 1/2
1005556 and 2 x 50mm
1005629

Optional accessories



Remote LED control kit w/10m
cable and Wi-Fi module 1007890

Specifications	Units	I-PAC 8ALX	I-PAC 12ALX	I-PAC 16ALX	I-PAC 22ALX
Air temperature range	°C	-5-43	-5-43	-5-43	-5-43
Water temperature range	°C	12-40	12-40	12-40	12-40

Performance – air 27°C 80% RH, water 27°C

Heating capacity	kW	9.5	13.0	20.0	25.0
COP range		13.2-5.4	13.5-5.6	13.5-5.7	13.8-5.8
Average COP at 50% speed		8.9	9.7	9.3	9.6

Performance – air 15°C 70% RH, water 26°C

Heating capacity	kW	7.0	9.5	13.5	17.0
COP range		6.9-4.2	7.0-4.0	7.0-4.2	7.2-4.0
Average COP at 50% Speed		6.3	6.1	6.3	6.4

Performance – air 5°C 70% RH, water 10°C

Heating capacity	kW	4.5	5.6	7.9	9.9
------------------	----	-----	-----	-----	-----

Performance – air 35°C 80% RH, water 28°C

Cooling capacity	kW	3.9	5.2	7.4	9.4
Power supply	V/Hz	230/1ph/50	230/1ph/50	230/1ph/50	230/1ph/50
Rated input power	kW	0.3-1.79	0.40-2.38	0.57-3.21	0.69-4.25
Maximum input current	A	9.5	12.5	19.5	20.0
Water flow	m ³ /h	3.0-5.0	4.0-6.0	7.0-10.0	10.0-12.0
Water connection	"/mm	1½/50	1½/50	1½/50	1½/50
Compressor		Inverter	Inverter	Inverter	Inverter
Condenser		Titanium	Titanium	Titanium	Titanium
R32 gas weight/CO ₂ equivalent	kg/t	0.6/0.41	0.9/0.61	1.1/0.74	2.0/1.35
Sound pressure level @ 10m	dB(A)	19.6-31.5	21.9-32.0	24.3-36.1	24.9-36.7
Product size (w x d x h)	mm	864 x 359 x 648	864 x 359 x 648	954 x 359 x 748	1084 x 429 x 948
Weight	kg	47	49	68	90

HPP-i 8-12-16



HPP-i

The low energy consumption coupled with high heat production makes the HPP-i heat pump an environmentally friendly way to heat your swimming pool.

Unlike alternative ways of heating pools, the HPP-i heat pump requires no fuel storage tank or high capacity electrical supply. It produces no smell, fumes or CO₂ gases.

HPP-i heat pumps are designed to work all year round when temperatures are above -5°C. Thus, the pool season can be extended for several months.

Rapid installation, flexible operation

Dantherm HPP-i heat pumps are easy to install and fully self-contained units. When it comes to operation, the HPP-i units offer a quiet, high efficient, reliable, and safe performance.

Included in the box



Rubber feet
(kit of 4) 108112



Drainage kit 1005558



Water union connectors 2 x 50mm
1005629

Dimensions (mm)

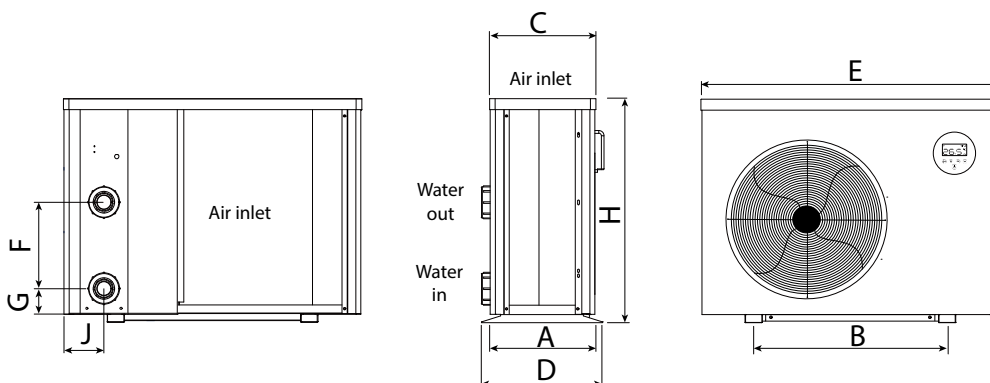

- Inverter heat pump
- Average COP >8.8 = 2 x more efficient than on/off heat pumps
- R32 = 675 GWP, (Global Warming Potential)
- Performance ratings from 9.5 to 20kW
- 9-11 dB(A) sound reduction compared to an equivalent on/off heat pump, with 'Whisper Mode'
- Multifunction operation functions can be set to heating, heat/cool and cooling
- Soft start-up
- Aluminium alloy
- Built-in Wi-Fi module
- PoolTherm App
- Winter cover included

Optional accessories



Remote LED control kit w/10m cable and Wi-Fi module 1007890

Controls

The HPP-i heat pump has an integrated controller with a touchscreen user interface.

The basic functions are:

- Function settings for: Heating, Cooling or Heat/Cool
- Parameter adjustment



HPP-i 8-12-16

Model	A	B	C	D	E	F	G	H	J
HPP-i 8	334	560	318	359	864	250	74	648	116
HPP-i 12	334	560	318	359	864	290	74	648	116
HPP-i 16	334	590	318	359	954	390	74	748	116

Specifications	Units	HPP-i 8	HPP-i 12	HPP-i 16
Air temperature range	°C	-5-43	-5-43	-5-43
Water temperature range	°C	12-40	12-40	12-40
Performance – air 27°C 80% RH, water 27°C				
Heating capacity	kW	9.5	13.0	20.0
COP range		13.2-5.4	13.5-5.6	13.5-5.7
Average COP at 50% speed		8.9	9.7	9.3
Performance – air 15°C 70% RH, water 26°C				
Heating capacity	kW	7.0	9.5	13.5
COP range		6.9-4.2	7.0-4.0	7.0-4.2
Average COP at 50% speed		6.3	6.1	6.3
Performance – air 5°C 70% RH, water 10°C				
Heating capacity	kW	4.5	5.6	7.9
Performance – air 35°C 80% RH, water 28°C				
Cooling capacity	kW	3.9	5.2	7.4
Power supply	V/Hz	230/1ph/50	230/1ph/50	230/1ph/50
Rated input power	kW	0.3-1.79	0.40-2.38	0.57-3.21
Rated input current	A	1.38-7.58	1.82-10.80	2.60-14.61
Maximum input current	A	9.5	12.5	19.5
Water flow	m ³ /h	3.0-5.0	4.0-6.0	7.0-10.0
Water connection	"/mm	1½/50	1½/50	1½/50
Compressor		Inverter	Inverter	Inverter
Condenser		Titanium	Titanium	Titanium
R32 gas weight/CO ₂ equivalent	kg/t	0.6/0.41	0.9/0.61	1.1/0.74
Sound pressure level @10m	dB(A)	19.6-31.5	21.9-32.0	24.3-36.1
Product size (w x d x h)	mm	864 x 359 x 648	864 x 359 x 648	954 x 359 x 748
Weight	kg	47	49	68

Swimming pool inverter heat pumps
CALOREX I-PAC+ 12-16-22-28



I-PAC 16

- Average COP >10.1 = 2 x more efficient than on/off heat pumps
- R32 = 675 GWP, (Global Warming Potential)
- Inverter heat pump
- Power ratings from 15 to 36kW
- 9-11 dB(A) sound reduction compared to an equivalent on/off heat pump, with 'Whisper Mode'.
- Operates in air temperatures of -10°C to 43°C
- Integrated controller with a touchscreen user interface
- Function settings for heating, cooling or heat/cool
- Soft start-up
- Aluminium alloy
- Built-in Wi-Fi module
- PoolTherm App
- Winter protection cover included

Benefits

- All year heating for outdoor and indoor pools
- Can operate down to -10°C ambient air temperature
- High heating performance at lower temperatures – ideal for quick pool heat up at the start of the season
- Pool heating at altitude
- Higher cooling capacity
- Most efficient models – highest COP

Optional accessories



Remote LED control kit w/10m cable and Wi-Fi module 1007890

Included in the box



Rubber feet (kit of 4) 1005526



Drainage kit 1005558



Water union connectors 2 x 11/2 1005556 and 2 x 50mm 1005629

Dimensions (mm)

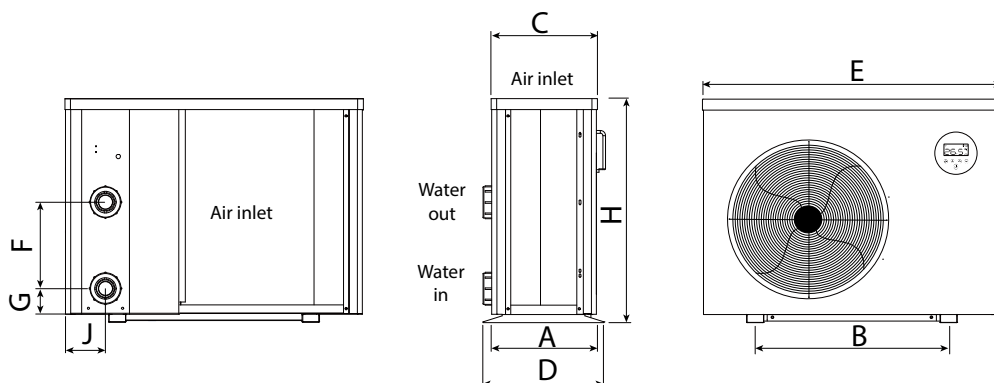

CALOREX I-PAC+ 12-16-22-28

Model	A	B	C	D	E	F	G	H	J
I-PAC 12ALY	334	590	318	359	954	340	74	648	107
I-PAC 16ALY	404	590	388	429	954	460	74	755	107
I-PAC 16BLY	404	590	388	429	954	460	74	755	107
I-PAC 22ALY	404	720	388	429	1084	620	74	948	107
I-PAC 22BLY	404	720	388	429	1084	620	74	948	107
I-PAC 28BLY	514	790	498	539	1154	650	74	948	128

Specifications	Units	I-PAC+ 12ALY	I-PAC+ 16ALY	I-PAC+ 16BLY	I-PAC+ 22ALY	I-PAC+ 22BLY	I-PAC+ 28BLY
Air temperature range	°C	-10-43	-10-43	-10-43	-10-43	-10-43	-10-43
Water temperature range	°C	12-40	12-40	12-40	12-40	12-40	12-40

Performance – air 27°C 80% RH, water 27°C

Heating capacity	kW	15.0	21.0	21.0	27.5	27.5	36.0
COP range		15.0-6.6	14.8-6.4	14.8-6.4	15.0-6.5	15.0-6.8	14.8-6.0
Average COP at 50% speed		10.6	10.3	10.3	10.3	10.3	10.2

Performance – air 15°C 70% RH, water 26°C

Heating capacity	kW	10.5	14.5	14.5	18.0	18.0	23.9
COP range		7.7-4.6	7.1-4.6	7.5-4.6	7.5-4.6	7.5-4.6	7.5-4.6
Average COP at 50% speed		6.4	6.3	6.3	6.3	6.3	6.3

Performance – air 5°C 70% RH, water 10°C

Heating capacity	kW	6.8	8.9	8.9	11.4	11.4	16.8
------------------	----	-----	-----	-----	------	------	------

Performance – air -10°C 70% RH, water 23°C

Heating capacity	kW	3.2	4.2	4.2	5.2	5.2	7.7
------------------	----	-----	-----	-----	-----	-----	-----

Performance – air 35°C 80% RH, water 28°C

Cooling capacity	kW	6.7	9.5	9.5	11.9	11.9	16.0
Power supply	V/Hz	230/1ph/50	230/1ph/50	400/3ph/50	230/1ph/50	400/3ph/50	400/3ph/50
Rated input power	kW	0.27-2.28	0.41-3.15	0.41-3.15	0.48-3.91	0.48-3.91	0.64-5.20
Maximum input current	A	13.5	17.0	5.8	20.0	7.0	9.5
Water flow	m ³ /h	5.0-7.0	8.0-10.0	8.0-10.0	10.0-12.0	10.0-12.0	12.0-18.0
Water connection	"/mm	1½/50	1½/50	1½/50	1½/50	1½/50	1½/50
Compressor		Inverter	Inverter	Inverter	Inverter	Inverter	Inverter
Condenser		Titanium	Titanium	Titanium	Titanium	Titanium	Titanium
R32 gas weight/CO ₂ equivalent	kg/t	0.9/0.61	1.2/0.81	1.2/0.81	2.0/1.35	2.0/1.35	2.7/1.82
Sound pressure level @ 10m	dB(A)	20.8-34.5	20.4-33.7	20.4-33.7	23.0-34.4	23.0-34.4	22.1-34.2
Product size (w x d x h)	mm	954 x 359 x 648	954 x 429 x 755	954 x 429 x 755	1084 x 429 x 948	1084 x 429 x 948	1154 x 539 x 948
Weight	kg	52	68	68	90	93	120

HPP-iw 12-16-22-28



HPP-iw

The low energy consumption coupled with high heat production makes the HPP-iw heat pump an environmentally friendly way to heat your swimming pool.

Unlike alternative ways of heating pools, the HPP-iw heat pump requires no fuel storage tank or high capacity electrical supply. It produces no smell, fumes or CO₂ gases.

HPP-iw heat pumps are designed to work all year round when temperatures are above -10°C. Thus, the pool season can be extended for several months.

Rapid installation, flexible operation

Dantherm HPP-iw heat pumps are easy to install and fully self-contained units. When it comes to operation, the HPP-iw units offer a quiet, high efficient, reliable, and safe performance.

Included in the box



Rubber feet
(kit of 4)
108112



Drainage kit
1005558



Water unit connectors
2 x 50mm 1005629

Dimensions (mm)

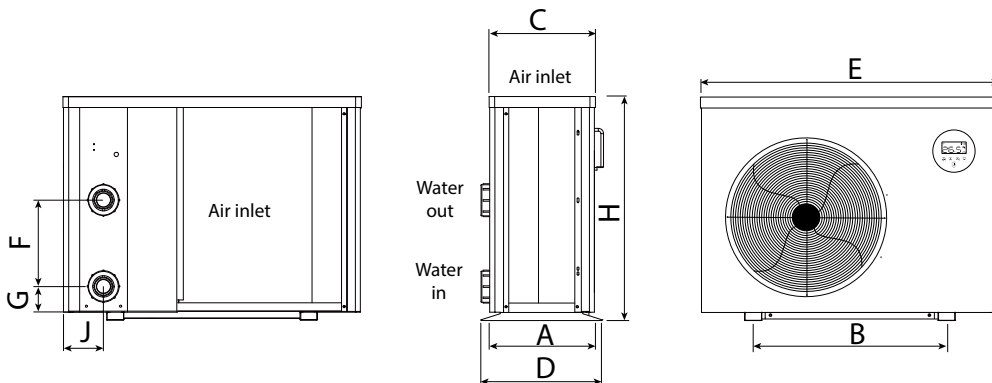

- Inverter heat pump
- Average COP >10.1 = 2 x more efficient than on/off heat pumps
- R32 = 675 GWP, (Global Warming Potential)
- Increased range of performance ratings from 15 to 36kW
- 9-11 dB(A) sound reduction compared to an equivalent on/off heat pump, with 'Whisper Mode'
- Multifunction operation functions can be set to heating, heat/cool and cooling
- Soft start-up
- Aluminium alloy
- Built-in Wi-Fi module
- PoolTherm App
- Winter cover included

Benefits

- All year heating for outdoor and indoor pools
- Can operate down to -10°C ambient air temperature
- High heating performance at lower temperatures – ideal for quick pool heat up at the start of the season
- Pool heating at altitude
- Higher cooling capacity
- Most efficient models – highest COP

Optional accessories



Remote LED control kit w/10m cable and Wi-Fi module 1007890

HPP-iw 12-16-22-28

Model	A	B	C	D	E	F	G	H	J
HPP-iw 12	334	590	318	359	954	340	74	648	107
HPP-iw16	404	590	388	429	954	460	74	755	107
HPP-iw 22	404	720	388	429	1084	620	74	948	107
HPP-iw 28	514	790	498	539	1154	650	74	948	128

Specifications	Units	HPP-iw 12	HPP-iw 16	HPP-iw 22	HPP-iw 28
Air temperature range	°C	-10-43	-10-43	-10-43	-10-43
Water temperature range	°C	12-40	12-40	12-40	12-40

Performance – air 27°C 80% RH, water 27°C

Heating capacity	kW	15.0	21.0	27.5	36.0
COP range		15.0-6.6	14.8-6.4	15.0-6.8	14.8-6.0
Average COP at 50% speed		10.6	10.3	10.3	10.2

Performance – air 15°C 70% RH, water 26°C

Heating capacity	kW	10.5	14.5	18.0	23.9
COP range		7.7-4.6	7.1-4.6	7.5-4.6	7.5-4.6
Average COP at 50% speed		6.4	6.3	6.3	6.3

Performance – air 5°C 70% RH, water 10°C

Heating capacity	kW	6.8	8.9	11.4	16.8
------------------	----	-----	-----	------	------

Performance – air -10°C 70% RH, water 23°C

Heating capacity	kW	3.2	4.2	5.2	7.7
------------------	----	-----	-----	-----	-----

Performance – air 35°C 80% RH, water 28°C

Cooling capacity	kW	6.7	9.5	11.9	16.0
Power supply	V/Hz	230/1ph/50	400/3ph/50	400/3ph/50	400/3ph/50
Rated input power	kW	0.27-2.28	0.41-3.15	0.48-3.91	0.64-5.20
Maximum input current	A	13.5	5.8	7.0	9.5
Water flow	m ³ /h	5.0-7.0	8.0-10.0	10.0-12.0	12.0-18.0
Water connection	"/mm	1½/50	1½/50	1½/50	1½/50
Compressor		Inverter	Inverter	Inverter	Inverter
Condenser		Titanium	Titanium	Titanium	Titanium
R32 gas weight/CO ₂ equivalent	kg/t	0.9/0.61	1.2/0.81	2.0/1.35	2.7/1.82
Sound pressure level @10m	dB(A)	20.8-34.5	20.4-33.7	23.0-34.4	22.1-34.2
Product size (w x d x h)	mm	954 x 359 x 648	954 x 429 x 755	1084 x 429 x 948	1154 x 539 x 948
Weight	kg	52	68	93	120

SET i-SILENT 10-15



i-SILENT 10

Offering a very high heat output using very little energy, the i-Silent range stands out for its environmental friendliness and operational cost effectiveness. In fact, their energy consumption is approximately half that of traditional on/off heat pumps and 1/10 of that of gas or electrical pool heaters.

In addition, it does not require a fuel storage tank or high-capacity electrical supply. It does not emit any CO₂ gases, fumes or smells.

Specifically designed for operation down to -10°C, the i-Silent heat pumps will extend your pool season by several months too.

Rapid installation, flexible operation

The i-Silent heat pumps are built with easy installation in mind. In terms of operation, you'll note that the highly efficient units are very quiet, reliable and safe to use.

- Inverter heat pump
- Average COP 9.7 = 2 x more efficient than on/off heat pumps
- R32 = 675 GWP, (Global Warming Potential)
- Increased range of performance ratings from 10.2 to 14.1kW
- 9-11 dB(A) sound reduction compared to an equivalent on/off heat pump, with 'Whisper Mode'
- Multifunction operation functions can be set to heating, heat/cool and cooling
- Soft start-up
- Robust housing made of eloxated aluminium
- Built-in Wi-Fi module
- PoolTherm App
- Winter protection cover included

Controls

The i-Silent heat pump has an integrated controller with a touchscreen user interface.

The basic functions are:

- Function settings for: Heating, Cooling or Heat/Cool
- 24-hour time clock via Wi-Fi
- Timer ON/OFF via Wi-Fi
- Parameter adjustment



Optional accessories



Remote LED control kit w/10m cable 109804

Dimensions (mm)

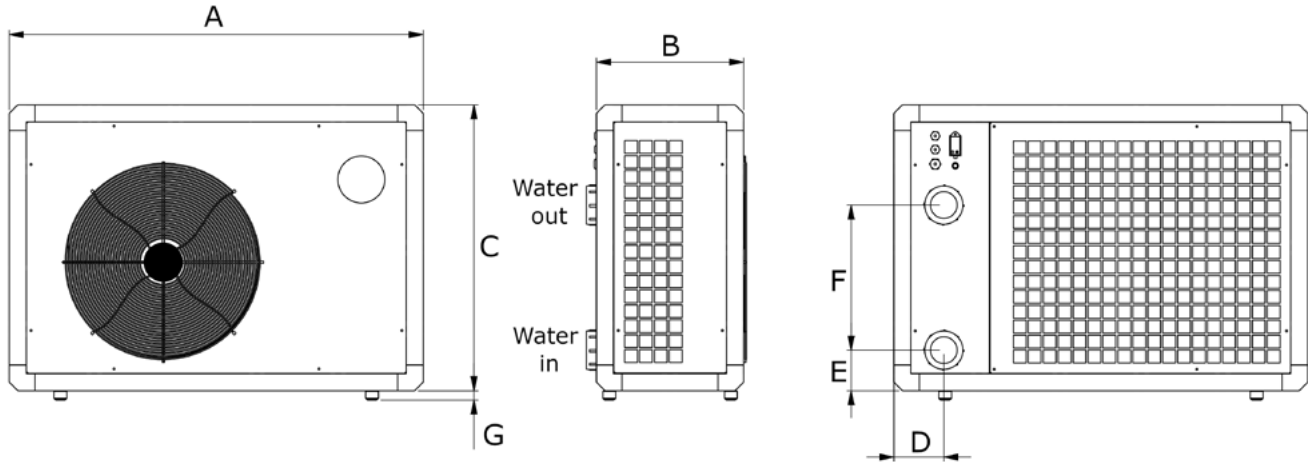

SET i-SILENT 10-15

Model	A	B	C	D	E	F	G
i-Silent 10	970	345	670	116	95	340	22
i-Silent 15	970	415	770	120	100	460	22

Specifications	Units	i-SILENT 10	i-SILENT 15
Operating temperature range	°C	-10-40	-10-40
Water temperature range	°C	12-40	12-40
Performance – air 15°C, 70% RH, water 26°C			
Heating capacity	kW	10.2	14.1
Performance – air 5°C, 70 % RH, water 10°C			
Heating capacity	kW	7.4	9.5
Performance – air 35°C, 80 % RH, water 28°C			
Cooling capacity	kW	6.5	9.3
Power supply	V/Hz	230/1ph/50	230/1ph/50 or 400/3ph/50
Rated input power	kW	2.2	3.1
Rated input current	A	10	13.6/3 x 4.5
Maximum input current	A	13.5	17.0/3 x 5.8
Water flow	m ³ /h	4-6	7-10
Water connection	"/mm	1½/50	1½/50
Compressor		Inverter	Inverter
Condenser		Titanium	Titanium
R32 gas weight/CO ₂ equivalent	kg	0.9/0.61	1.2/0.81
Sound level @ 10m	dB(A)	20.5-24.0	20.5-33.5
Sound level @ 1m	dB(A)	40-45	40-53
Product size (w x d x h)	mm	980 x 360 x 680	980 x 420 x 780
Weight	kg	55	70

Swimming pool inverter heat pumps
CALOREX V-PAC 12-16-22



- Average COP >8.7 = 2 x more efficient than on/off heat pumps
- R32 = 675 GWP, (Global Warming Potential)
- Inverter heat pump
- Power ratings from 14 to 24kW
- 9-11 dB(A) noise reduction compared to traditional on/off heat pumps, with 'Whisper Mode'.
- Ideal for confined spaces
- Operates in air temperatures of -5°C to 43°C
- Integrated controller with a user interface
- Function settings for heating, cooling or heat/cool
- Soft start-up
- ABS cabinet

V-PAC 12

Inverter technology allows for efficient control of the pool temperature, and the V-PAC only uses what energy is needed when it is required. High efficiency with modulating step-less inverter compressor.

Included in the box



Rubber feet (kit of 4) 1008099



Drainage kit 1008091



Water union connectors 2 x 11/2 x 50mm 1007621

Dimensions (mm)

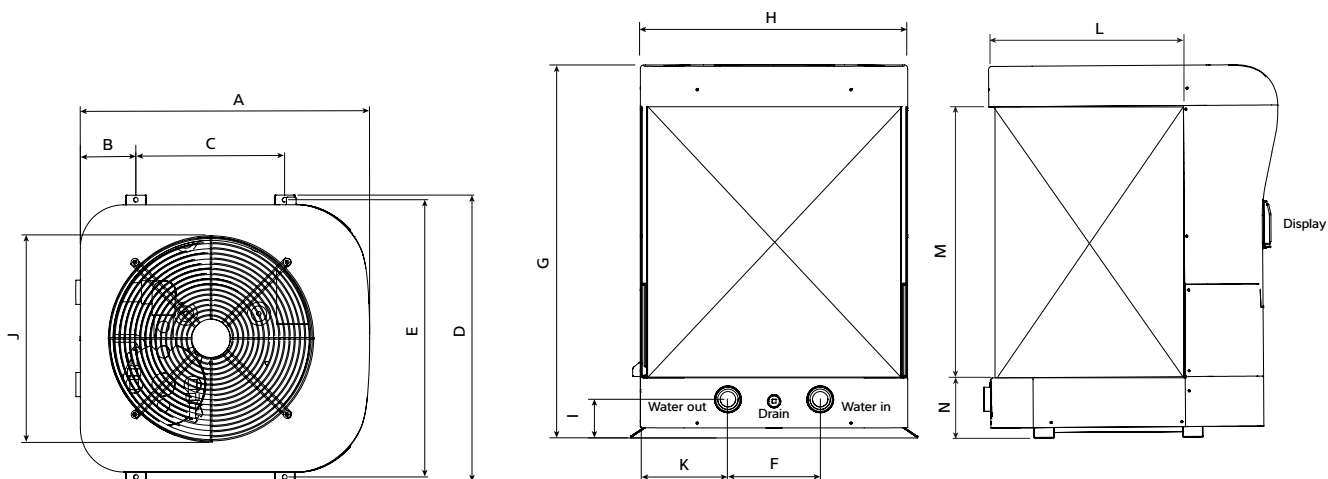

Swimming pool inverter heat pumps
CALOREX V-PAC 12-16-22

Model	A	B	C	D	E	F	G
V-PAC 12ALX	650	98	362	650	626	220	835
V-PAC 16ALX	650	98	362	650	626	220	835
V-PAC 22ALX	752	138	387	745	721	240	967

Model	H	I	J	K	L	M	N
V-PAC 12ALX	600	92	490	190	430	588	130
V-PAC 16ALX	600	92	490	190	430	588	130
V-PAC 22ALX	695	92	530	228	505	705	157

Specifications	Units	V-PAC 12ALX	V-PAC 16ALX	V-PAC 22ALX
Air temperature range	°C	-5-43	-5-43	-5-43
Water temperature range	°C	8-40	8-40	8-40
Performance – air 27°C 80% RH, water 27°C				
Heating capacity	kW	14.1	18.5	24.4
COP range		13.5-6.28	13.5-6.03	13.5-5.14
Average COP at 50% speed		9.7	9.3	8.8
Performance – air 15°C 70% RH, water 26°C				
Heating capacity	kW	10.6	13.6	17.8
COP range		8.5-5.11	8.4-5.02	6.2-4.14
Average COP at 50% speed		6.5	6.4	4.7
Performance – air 5°C 70% RH, water 10°C				
Heating capacity	kW	6.6	9.5	13.9
Performance – air 35°C 80% RH, water 28°C				
Cooling capacity	kW	6.0	7.5	10.9
Power supply	V/Hz	230/1ph/50	230/1ph/50	230/1ph/50
Rated input power	kW	0.20-2.24	0.23-3.06	0.75-4.75
Maximum input current	A	12.5	15.5	24.5
Water flow	m ³ /h	5.0	6.5	9.0
Water connection	"/mm	1½/50	1½/50	1½/50
Compressor		Inverter	Inverter	Inverter
Condenser		Titanium	Titanium	Titanium
R32 gas weight/CO ₂ equivalent	kg/t	0.8/0.54	0.8/0.54	1.7/1.15
Sound pressure level @ 10m	dB(A)	< 29	< 30	< 30
Product size (w x d x h)	mm	650 x 650 x 835	650 x 650 x 835	745 x 752 x 967
Weight	kg	70	80	95

CALOREX I-PAC 50-100BLY



I-PAC 50

Inverter technology allows for efficient control of the pool temperature, and the I-PAC BLY only uses what energy is needed when it is required. High efficiency with modulating step-less inverter compressor giving an average COP of 10.5 (I-PAC 50BLY) and 10 (I-PAC 100BLY).



- 2 x more efficient than on/off heat pumps
- Inverter heat pump
- Titanium heat exchanger
- Fully automatic operation
- Comprehensive circuit protection
- Quiet and efficient axial fans
- Weather proof construction
- Multifunction operation functions can be set to heating, heat/cool and cooling
- 10-12 dB(A) noise reduction compared to traditional on/off heat pumps, with 'Whisper Mode'
- Soft start-up
- Aluminium alloy
- 50/60Hz compatible
- BMS Connectivity
- Built-in Wi-Fi module
- PoolTherm App

CALOREX I-PAC 50-100BLY

Specifications	Units	I-PAC 50BLY	I-PAC 100BLY
Air temperature range	°C	-7-43	-7-43
Performance – air 27°C 80% RH, water 27°C			
Heating capacity	kW	60.2	115.0
Average COP @50% speed		10.5	10.0
Performance – air 15°C 70% RH, water 26°C			
Heating capacity	kW	40.1	80.8
Average COP @50% speed		7.0	6.7
Performance – air 5°C 70% RH, water 26°C			
Heating capacity	kW	27	55
Average COP @50% speed		4.8	4.8
Performance – air 35°C 80% RH, water 28°C			
Cooling capacity	kW	26.8	53.5
Power supply	V/Hz	400/3ph/50-60	400/3ph/50-60
Rated input power	kW	2.10-8.18	4.25-17.0
Rated current input	A	3.05-11.90	6.16-24.7
Max. input current	A	19	38
Water flow	m ³ /h	20-25	40-50
Water pressure drop	kPa	13	25
Water connection	mm	75	110
Compressor		Inverter	Inverter
Heat exchanger		Titanium	Titanium
R410A gas weight/CO ₂ equivalent	kg/t	8.0/16.70	16/33.41
Sound pressure level @ 10m	dB(A)	33-41	35-44
Product size (w x d x h)	mm	1020 x 1100 x 1260	2100 x 1090 x 1280
Weight	kg	230	448



I-PAC 50

Inverter technology allows for efficient control of the pool temperature, and the I-PAC BHC only uses what energy is needed when it is required. High efficiency with modulating step-less inverter compressor giving an average COP of 10.5 (I-PAC 50BHC) and 10.0 (I-PAC 100BHC).



- 2 x more efficient than on/off heat pumps
- Inverter heat pump
- Titanium heat exchanger
- Fully automatic operation
- Comprehensive circuit protection
- Quiet and efficient axial fans
- Weather proof construction
- Multifunction operation functions can be set to heating, heat/cool and cooling
- 10-12 dB(A) noise reduction compared to traditional on/off heat pumps, with 'Whisper Mode'
- 'Enhanced Vapour Injection' technology for efficient operation, even on the hottest summer days
- Soft start-up
- Aluminium alloy
- Optimised for Gulf climate
- BMS Connectivity
- Built-in Wi-Fi module
- PoolTherm App

CALOREX I-PAC 50-100BHC

Specifications	Units	I-PAC 50BHC	I-PAC 100BHC
Air temperature range	°C	0-55	0-55
Performance – air 27°C 80% RH, water 27°C			
Heating capacity	kW	60.2	115.0
Average COP @ 50% speed		10.5	10.0
Performance – air 15°C 70% RH, water 26°C			
Heating capacity	kW	40.1	80.8
Average COP @ 50% speed		7.0	7.0
Performance – air 45°C 80% RH, water 32°C			
Cooling capacity	kW	25.1	50.3
Power supply	V/Hz	400/3ph/50	400/3ph/50
Rated input power	kW	2.26-8.90	4.68-17.5
Rated current input	A	3.27-12.9	6.78-25.3
Max. input current	A	19	38
Water flow	m ³ /h	20-25	40-50
Water pressure drop	kPa	13	25
Water connection	mm	75	110
Compressor		Inverter	Inverter
Heat exchanger		Titanium	Titanium
R410A gas weight/CO ₂ equivalent	kg/t	8.0/16.70	16.0/33.41
Sound pressure level @ 10m	dB(A)	33-41	33-44
Product size (l x w x h)	mm	1020 x 1100 x 1260	2100 x 1090 x 1280
Weight	kg	230	448

CF 75 SPARK



CF 75 SPARK

- Designed for indoor and outdoor use
- Can be placed on the floor or hung from a ceiling
- Galvanised steel combustion chamber
- Reliable twin spark ignition
- Natural gas or LP gas burner
- High efficiency heat exchanger
- Overheat thermostat
- Closed motor to assure safety and dependability even in harsh environments
- Galvanised steel body

Included in the box



Diverter



LPG to natural gas kit

Optional accessories



Analogue thermostat TH5 with cable
3m - **4150.109**
10m - **4150.112**



Digital thermostat THD with cable
5m - **4150.133**
10m - **4150.134**

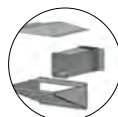

Kit for outdoors
Galvanised - **4015.164**



Brackets
Galvanised - **4230.120**

Specifications	Units	CF 75 SPARK
Heating power	kW	75
	Btu/h	255,900
	kcal/h	64,500
Air flow	m ³ /h	2,100
Thermostat control		Optional
Fuel consumption (LPG)	m ³ /h	2.3
Fuel consumption (natural gas)	m ³ /h	8.0
Electric power	kW	0.5
Power supply	V/Hz	220-240/1ph/50
Rated current	A	2.8
Product size (l x w x h)	mm	788 x 464 x 719
Box size (l x w x h)	mm	825 x 515 x 780
Net/gross weight	kg	57/61
Pallet	pcs	4

F 30-60-80



F 30
F 60
F 80

**ErP
2021**



Control panel





Heat exchanger

- Large built-in oil tank
- Integrated burner with electronic flame control and photocell cut-off
- Fan limit thermostat with automatic reset
- Summer/winter switch for ventilation only
- Centrifugal fan
- Stainless steel combustion chamber
- High efficiency dual-circuit heat exchanger
- Wide inspection doors for easy cleaning
- Built-in thermostat
- Can run on HVO100 biofuel, diesel or kerosene

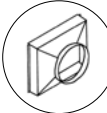
Optional accessories (on request)

- 

Circular 1-way air outlet panel
F 30, F 60 - Ø500mm
F 80 - Ø600mm
- 

2-way outlet panel
F 30, F 60 - 2xØ400mm
F 80 - 2 x Ø500mm
- 

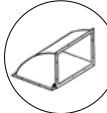
360° rotating diffuser for F 30 and F 60
- 

Plenum for connection to rectangular supply ducts
- 

Air return adaptor
F 30 - Ø505mm
F 60 - Ø565mm
F 80 - Ø625mm
- 

Supply ducts
- 

Chimney elements
- 

Set of 4 stainless steel feet, height 11cm

Specifications	Units	F 30	F 60	F 80
Heating power	kW	27.55	59.63	79.88
Air flow	m ³ /h	2,700	6,000	7,800
Performance	%	94.13	93.58	94.08
Fuel consumption	kg/h	2.18	4.71	6.32
Air pressure	Pa	150	150	150
Power supply	V/Hz	230/1ph/50	230/1ph/50	230/1ph/50
Electric power	W	690	1,360	1,800
Tank capacity	l	80	110	110
Air flow temperature increase (ΔT)	°C	31	37,5	31
Flue tube diameter	mm	153	153	153
Product size (l x w x h)	mm	1010 x 530 x 1745	1045 x 600 x 1920	1400 x 640 x 2090
Weight	kg	161	212	291

SP 30-60



ErP
2021



SP 30
SP 60













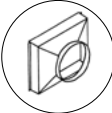

Options: 360° pivoting
air diffuser and feet kit



- Large built-in oil tank as standard
- 4-sided supply plenum with directional vanes
- Complete tubular structure for high rigidity
- Stainless steel combustion chamber with high-efficiency heat exchanger
- Integrated control panel with protection, indicator lights and selector switch
- Body panels with reinforcement
- High-pressure centrifugal fan with dual intake
- Summer-winter switch for ventilation only
- Ideally suited to heating garages, workshops, warehouses, livestock buildings, etc. or keeping them frost-free.
- Can run on HVO100 biofuel, diesel or kerosene

Optional accessories (on request)

 Analogue thermostat	 Timer and clock	 360° rotatable air diffuser	 Custom-made plenum for connection to ductwork
 Circular air outlet SP 30 - Ø450mm SP 60 - Ø500mm	 2-way circular air outlet 2x Ø400mm	 Air return adaptor SP 30 - Ø505mm SP 60 - Ø565mm	 Stainless steel feet kit, height 11 cm
 Fuel storage tank	 Combi-fuel	 Chimney elements	 Supply ducts

Specifications	Units	SP 30	SP 60
Heating power	kW	27.55	59.53
Air flow	m ³ /h	2,700	6,000
Performance	%	93.9	93.6
Fuel consumption	kg/h	2.18	4.7
Air pressure	Pa	150	150
Power supply	V/Hz	230/1ph/50	230/1ph/50
Electric power	W	690	1.360
Chimney connection diameter	mm	153	153
Product size (l x w x h)	mm	511 x 935 x 1605	580 x 955 x 1800
Weight	kg	115	153

SF RANGE



ErP
2021



SF



- Vertical or horizontal monoblocks
- Supplied with or without oil, propane or natural gas burner
- High-pressure centrifugal fan with double intake
- High air flow
- 2mm thick combustion chamber with flame return
- Reinforced chamber bottom in refractory stainless steel
- Heat exchanger with stainless steel flue gas turbulators
- 10/10mm thick pre-painted galvanised sheet metal casing
- Panel thermal insulation
- Integrated watertight electrical panel
- Inspection hatches for easy maintenance of the firebox/exchanger assembly and flue gas manifold
- Bi-thermostat "fan-limit" doubled with an independent overheating thermostat
- Can run on HVO100 biofuel, diesel or kerosene



SF/H - horizontal version

Optional accessories (on request)



Analogue thermostat

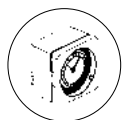

Timer and clock

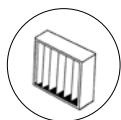

Plenum with directional air outlets (from 2 to 9 depending on model)



Outdoor installation kit

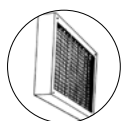

Air filtration box

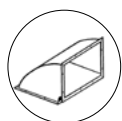

Connection plenum for ducts

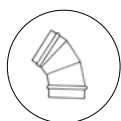

Supply ducts



Chimney elements

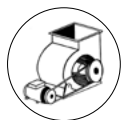

2-speed ventilation

SF RANGE



Direct blow out

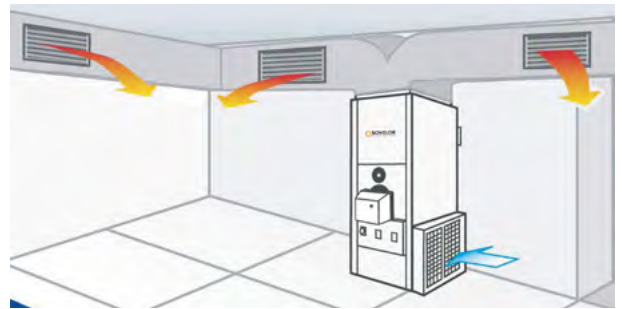

Blowing via ductwork

Specifications	Units	SF 600	SF 700	SF 900	SF 1200
Heating power	kW	581.4	697.7	872	1,163
Air flow	m ³ /h	35,000	43,500	53,000	72,000
Air pressure	Pa	200	200	180	200
Fuel consumption	kg/h	49	58.8	73.5	98
Natural gas (G20)	m ³ /h	61.4	73.7	92.1	122.9
Propane gas (G31)	kg/h	45.4	54.5	68.1	90.8
Power supply	V/Hz	380/3ph/50	380/3ph/50	380/3ph/50	380/3ph/50
Electric power	W	2 x 4,000	2 x 5,500	2 x 7,500	3 x 7,500
Noise level at 1.5 m	dB(A)	73	74	74	70
Fan	pcs	2	2	2	3
Air blast range	m	80	87	95	110

From SF 600 to SF 1200: delivery in 2 parts to be assembled on site (combustion part + ventilation part)

Specifications	Units	SF 70	SF 95	SF 130	SF 190	SF 260	SF 360	SF 500
Heating power	kW	60.7	92	115.9	185.8	232.6	348.8	465.1
Air flow	m ³ /h	4,300	5,800	7,800	11,100	15,000	20,250	31,000
Air pressure	Pa	100	160	180	200	200	180	240
Fuel consumption	kg/h	5.1	7.7	9.8	15.6	19.6	29.4	39.2
Natural gas (G20)	m ³ /h	6.4	9.7	12.3	19.6	24.6	36.8	49.1
Propane gas (G31)	kg/h	4.7	7.2	9	14.5	18.1	27.2	36.3
Power supply	V/Hz	230/1ph/50	380/3ph/50	380/3ph/50	380/3ph/50	380/3ph/50	380/3ph/50	380/3ph/50
Electric power	W	740	1,100	1,500	3,000	4,000	2 x 3,000	2 x 4,000
Noise level at 1.5 m	dB(A)	65	66	67	71	73	73	73
Fan	pcs	1	1	1	1	1	2	2
Air blast range	m	17	20	24	35	50	65	75

From SF 70 to SF 500: delivery in one block

SF RANGE



Dimensions

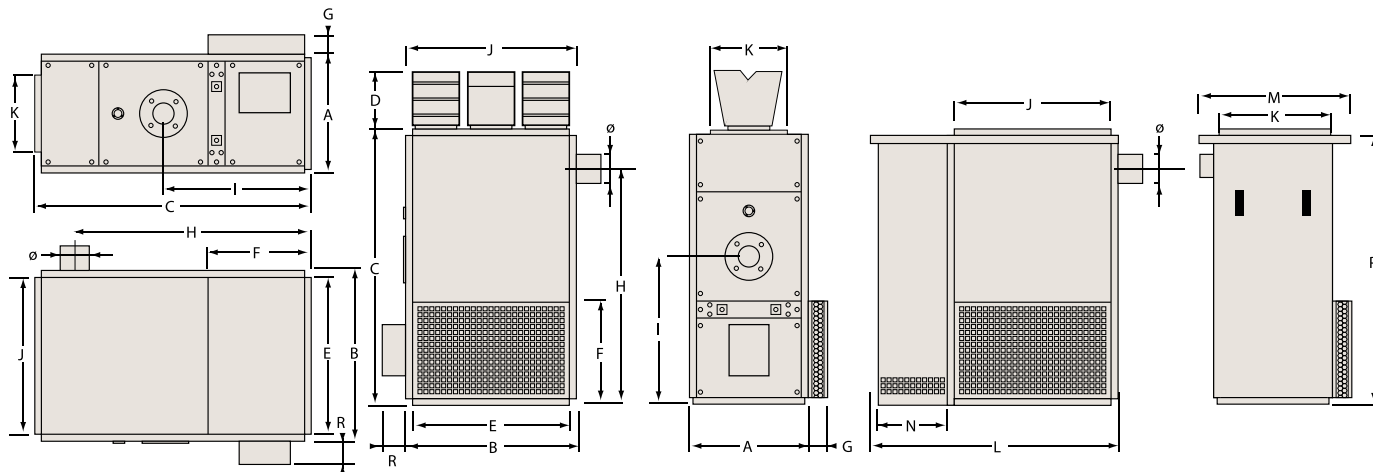

Horizontal version

Vertical version (standard)

Outdoor versions (without plenum)

mm	SF 70	SF 95	SF 130	SF 190	SF 260	SF 360	SF 500	SF 600	SF 700	SF 900	SF 1200
A	760	760	760	960	960	1,160	1,160	1,360	1,360	1,360	1,360
B	950	1,150	1,150	1,290	1,490	1,760	2,160	2,530	2,530	3,030	3,930
C	1,760	1,860	1,860	2,050	2,050	2,390	2,390	3,100	3,100	3,100	3,100
D	425	425	425	530	530	530	530	530	530	535	535
E	730	930	930	1,070	1,270	1,540	1,940	2,310	2,310	2,720	3,620
F	500	600	600	700	700	800	800	950	950	950	950
G	160	160	160	160	160	160	160	180	180	180	180
H	1,395	1,490	1,490	1,775	1,775	2,120	2,120	2,730	2,730	2,730	2,730
I	1,010	1,105	1,105	1,290	1,290	1,460	1,460	1,850	1,850	1,850	1,850
J	800	1,000	1,000	1,160	1,360	1,490	1,990	2,080	2,080	2,890	3,790
K	500	500	500	600	600	800	800	1,100	1,100	1,100	1,100
L	-	1,650	1,650	1,920	2,120	2,550	2,950	3,650	3,650	4,150	5,050
M	-	830	830	1,050	1,050	1,250	1,250	1,450	1,450	1,450	1,450
N	-	460	460	590	590	750	750	980	980	980	980
P	-	1,795	1,795	1,985	1,985	2,280	2,280	3,025	3,025	3,025	3,025
R	200	200	200	200	200	200	200	300	300	300	300
Ø	160*	160*	160*	200	200	250	250	300	300	350	350
Weight kg**	305	380	385	610	710	910	1,010	1,660	1,690	1,900	2,300

SF RANGE



Combustion chamber with 5-year guarantee, thickness 2mm



Fan-motor unit with frame

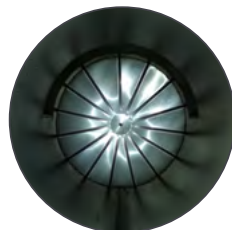

Combustion chamber bottom



Electrical panel with protection (IP44)

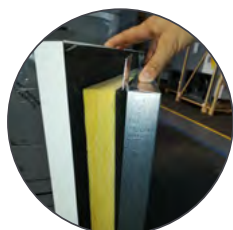

Thermal insulation of panels

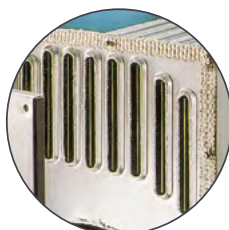

Heat exchanger inspection hatch



Filter box (optional)

SF standard elements

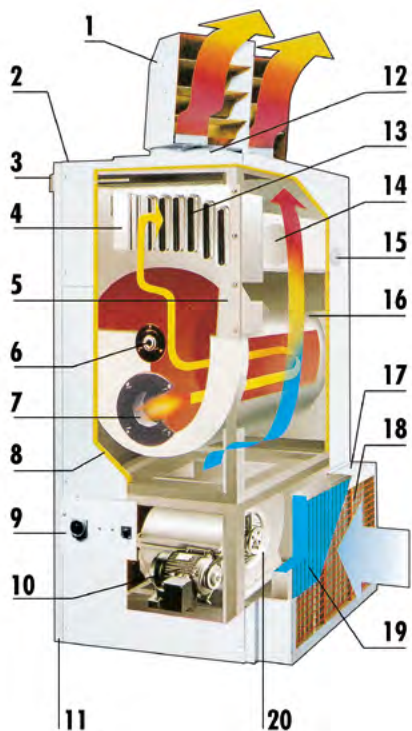

1. Air flow
Via ductwork or plenum with 360° air diffuser
2. Control astat
3. Fan-limit astat
4. Turbulators
5. Heat exchanger inspection hatch
6. Control eye
7. Burner adapter plate
8. Insulation
9. Control panel
10. Ventilation motor
11. Casing
12. Outlet panel to connect the air diffuser or to the ductwork
(see dimensions J and K)
13. Heat exchanger
14. Exhaust gas collector
15. Manifold inspection hatch
16. Combustion chamber
17. Filter box (optional) adaptable to either side of the heater
18. Intake grille
19. Intake filter (optional)
20. Fan

SF/HP RANGE



**ErP
2021**

SF/HP 136
SF/HP 236



- High-pressure centrifugal fan with dual intake
- Wide range of combinations to provide the most appropriate and efficient solution for every need
- Combustion chambers with high-efficiency heat exchangers
- 2-stage burners to adapt the heat output as closely as possible to requirements
- The imposing size of the SF/HP means that they are delivered in several parts to be assembled on site
- Vertical version as standard horizontal version on request
- Air supply and extraction configurations can be adapted to meet specific requirements
- Optional burner box with door for direct outdoor installation
- SF/HP SPORT heaters have been specially developed for heating indoor sports pitches. They are fully enclosed and designed for permanent outdoor installation
- Can run on HVO100 biofuel, diesel or kerosene



SF/HP 342
SF/HP 495
SF/HP 630

SF/HP units are particularly suitable for heating and ventilating industrial processes, compensating for hot air in rooms with air extraction, surface treatment buildings, drying rooms, paint booths and heating with distribution via a network of ducts with high stresses.

Optional accessories (on request)



G4 bag filters
(1 filter per fan)

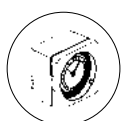

Pressure and airflow adjustment
(1 register per fan)



Custom-made supply plenum



Burner compartment for outdoor installation



Chimney elements

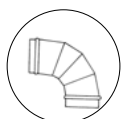

Supply ducts



Extension cable
10m

SF/HP RANGE



Specifications	Units	SF 136	SF 136	SF 236	SF 236	SF 236	SF 236	SF 236
Type		HP 1	HP 2	HP 1	HP 2	HP 3	HP 4	HP 5
Heating power	kW	150	150	260	260	260	260	260
Electric power	Type	380	380	380	380	380	380	380
No. of fans x fan power	No. x kW	1 x 4	1 x 5.5	1 x 4	1 x 5.5	1 x 7.5	1 x 9.2	1 x 11
Max. fuel consumption	kg/h	12.7	12.7	21.9	21.9	21.9	21.9	21.9
Max. propane gas (G31)	kg/h	10.7	10.7	18.6	18.6	18.6	18.6	18.6
Max. natural gas (G20)	m ³ /h	14.3	14.3	24.8	24.8	24.8	24.8	24.8
Air flow	m ³ /h	15,000	19,000	16,000	20,000	24,000	26,000	29,000
Air pressure	Pa	150	200	150	200	250	250	250
Temperature increase (DT)	°C	15-26	15-20.6	21.2-42.3	17-33.9	15-28.3	15-26.1	17.6-23.4
Product size (l x w x h)	mm	1500 x 1200 x 3410	1500 x 1200 x 3410	1500 x 1200 x 3410	1500 x 1200 x 3410	1500 x 1200 x 3410	1500 x 1200 x 3410	1500 x 1200 x 3410
Weight	kg	740	750	760	775	772	810	820

Specifications	Units	SF 342	SF 342	SF 342	SF 342	SF 342
Type		HP 1	HP 2	HP 3	HP 4	HP 5
Heating power	kW	380	380	380	380	380
Electric power	Type	380	380	380	380	380
No. of fans x fan power	No. x kW	2 x 4	2 x 5,5	2 x 7,5	2 x 9,2	2 x 11
Max. fuel consumption	kg/h	32.1	32.1	32.1	32.1	32.1
Max. propane gas (G31)	kg/h	27.1	27.1	27.1	27.1	27.1
Max. natural gas (G20)	m ³ /h	36.2	36.2	36.2	36.2	36.2
Air flow	m ³ /h	32,000	40,000	48,000	52,000	58,000
Air pressure	Pa	150	200	250	250	250
Temperature increase (DT)	°C	15.3-30.6	15-24.5	15-20.4	15-18.9	15-16.9
Product size (l x w x h)	mm	2400 x 2250 x 3410	2400 x 2250 x 3410	2400 x 2250 x 3410	2400 x 2250 x 3410	2400 x 2250 x 3410
Weight	kg	1,130	1,160	1,154	1,230	1,250

Specifications	Units	SF 495	SF 495	SF 495	SF 495	SF 630	SF 630	SF 630	SF 630
Type		HP 1	HP 2	HP 3	HP 4	HP 1	HP 2	HP 3	HP 4
Heating power	kW	550	550	550	550	700	700	700	700
Electric power	Type	380	380	380	380	380	380	380	380
No. of fans x fan power	No. x kW	3 x 4	3 x 5.5	3 x 7.5	3 x 9.2	4 x 4	4 x 5.5	4 x 7.5	4 x 9.2
Max. fuel consumption	kg/h	46.4	46.4	46.4	46.4	59.1	59.1	59.1	59.1
Max. propane gas (G31)	kg/h	39.3	39.3	39.3	39.3	50	50	50	50
Max. natural gas (G20)	m ³ /h	52.4	52.4	52.4	52.4	66.7	66.7	66.7	66.7
Air flow	m ³ /h	48,000	60,000	72,000	78,000	64,000	80,000	96,000	104,000
Air pressure	Pa	150	100	100	100	100	100	100	100
Temperature increase (DT)	°C	15-29.6	15-23.7	15-19.7	15-18.2	15-28.2	15-22.6	15-18.8	15-17.4
Product size (l x w x h)	mm	3600 x 2250 x 3470	3600 x 2250 x 3470	3600 x 2250 x 3470	3600 x 2250 x 3470	4800 x 2250 x 3470	4800 x 2250 x 3470	4800 x 2250 x 3470	4800 x 2250 x 3470
Weight	kg	1,930	1,975	1,966	2,080	2,540	2,600	2,588	2,740

DANTHERMGROUP



PROFESSIONAL INSTALLED

DRYING AND HUMIDITY CONTROL SOLUTIONS

FOR SWIMMING POOLS, INDUSTRY, BUILDINGS, AGRICULTURE, FOOD PRODUCTION, STORAGE AND PHARMACEUTICAL

Dantherm[®]
CLIMATE SOLUTIONS

TROTEC
CLIMATE SOLUTIONS

DANX 1-2-3 XD



DANX 1-2-3 XD

DanX XD with double crossflow heat exchanger

The DanX XD is a very effective ventilation system that uses outdoor air to provide dehumidification using a double cross-flow exchanger that delivers up to a 95% heat recovery. This reduces energy consumption and total operating costs, thus making the unit perfect for managing humidity and temperature in the pool room.

For both DanX HP and DanX XD

The built-in mixing function takes care not to add any more outdoor air than necessary to provide a comfortable indoor climate. Free cooling is also an option during the summer, where the unit can add up to 100% outdoor air into the pool area through a by-pass. The unit's compact, integrated design enables optimal installation in the technical room. Convenient top or side connections ensure easy access to ducts.

- Built-in user friendly control system for high-quality demand management Automatic monitoring and control of pool hall temperature and humidity The custom-built software runs the unit as efficiently as possible under different conditions
- Double crossflow heat exchangers with a high efficiency of more than 95% and a low pressure drop
- Built-in by-pass for free cooling in summertime
- Highly energy-efficient EC plug fans
- Efficient M5/ePM10 70% and F7/ePM1 55% compact filters with low pressure drop
- Self-bearing cabinet with hot-dip galvanised, powder-painted sandwich panels with 50mm mineral wool insulation, internal partition walls with 30mm and bottom frame with adjustable feet
- Designed to withstand the aggressive swimming pool environment (Corrosion class C4 according to EN/ISO 12944-2), with epoxy-coated crossflow heat exchangers heating coil with aluminium frame, pre-painted fins and epoxy coating to protect all fasteners, bolts, nuts
- Two large inspection doors with strong hinges and tongue locks and handles for easy access for service
- All-in-one box solutions for easy and quick installation – all sensors and electrical components pre-connected
- BMS communication with either Modbus or BACnet

Optional accessories

- Water trap - 092447
- Fire thermostat 40°C/70°C - 101277
- Attendance transmitter - 076092
- Outdoor sensor - 018092
- Frost thermostat for LPHW coil Auto reset - 101953
- Frost thermostat for LPHW coil MAN reset - 102092
- 3.5" control panel, touch screen - 109404

Specifications	Units	DANX 1 XD	DANX 2 XD	DANX 3 XD
Nominal air volume	m ³ /h	1,000	1,750	2,750
Max. air volume	m ³ /h	1,300	2,100	3,700
Max. external duct pressure*	Pa	350	350	350
Outdoor air volume	%	0-100	0-100	0-100
Dehumidification capacity VDI 2089**	kg/h	7	11	18
Max. power consumption	kW	1.1	1.2	1.9
Power supply	V/Hz	230/1ph/50	230/1ph/50	230/1ph/50
Product size (w x d x h)	mm	1750 x 515 x 1570	1750 x 780 x 1570	2250 x 890 x 1990
Weight	kg	254	344	465

* at nominal air volume, ** at 30°C/54% indoor

DANX 1-2-3 XD



DanX 1 XD dimensions (mm)

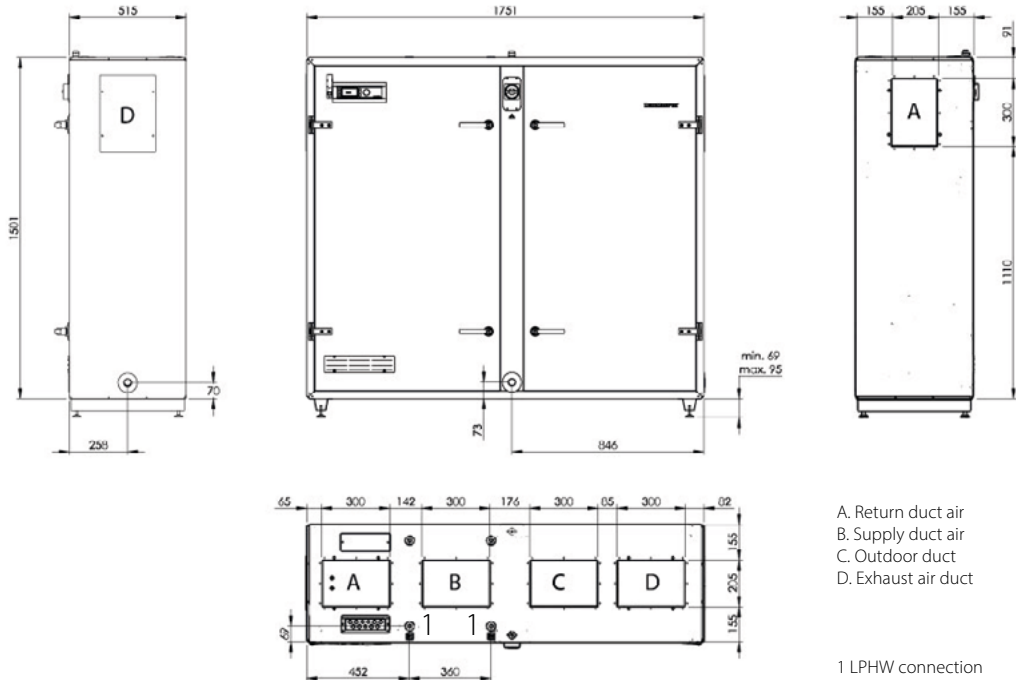

- A. Return duct air
- B. Supply duct air
- C. Outdoor duct
- D. Exhaust air duct

1 LPHW connection

The unit shown in the picture is left hand position.

DanX 2 XD dimensions (mm)

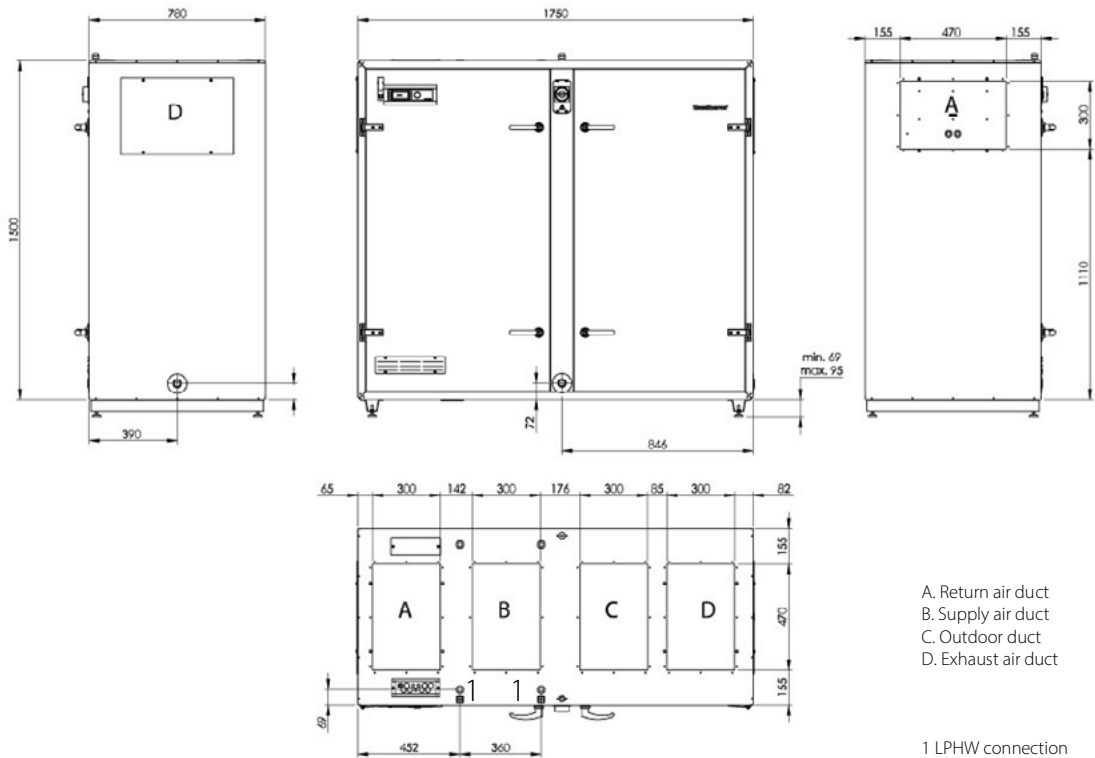

- A. Return air duct
- B. Supply air duct
- C. Outdoor duct
- D. Exhaust air duct

1 LPHW connection

The unit shown in the picture is left hand position.

DANX 1-2-3 XD



DanX 3 XD dimensions (mm)

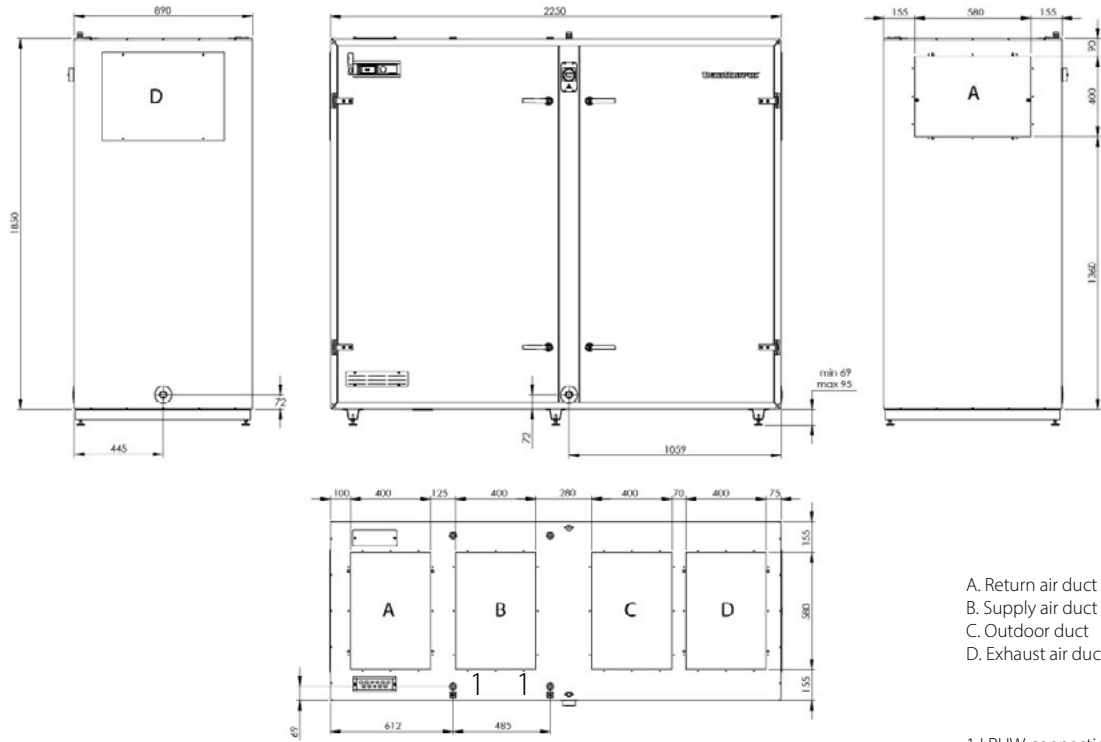

- A. Return air duct
- B. Supply air duct
- C. Outdoor duct
- D. Exhaust air duct

1 LPHW connection

The unit shown in the picture is left hand position.

DANX XKS



DANX XKS

DanX XKS with crossflow heat exchanger

The DanX XKS is a very effective outdoor air dehumidification system with highly efficient crossflow heat exchanger. This system perfectly controls the humidity and indoor temperature while offering significant running cost reductions due to real energy savings of up to 80%. The integrated mixing function ensures that only the exact quantity of outdoor air needed is supplied – which keeps running costs at a minimum.

Free cooling is also an option during summer, when the unit can add up to 100% outdoor air into the pool area through the integrated by-pass.

For countries with high outdoor summer temperatures, the system can be equipped with an additional cooling coil for further dehumidification and air cooling.

Optionally, we offer various fan types, filter qualities and coils to perfectly match to the requirements.

- User-friendly control system for high-quality demand management, automatic monitoring, control of temperature and humidity of the pool hall
- Crossflow heat exchanger with a high efficiency of up to 75% and a low pressure drop
- Built-in by-pass for free cooling in the summertime
- Highly energy-efficient EC plug fans
- Efficient bag filters in different lengths and qualities with low pressure drops are available
- Load-bearing frame construction module with hot-dip galvanised, powder-painted sandwich panels with 50mm mineral wool insulation, internal partition walls with 30mm and bottom frame with adjustable feet
- Designed to withstand the aggressive swimming pool environment (Corrosion class C4 according to EN/ISO 12944-2), with epoxy-coated crossflow heat exchanger, heating coil with aluminium frame, pre-painted fins and epoxy coating to protect all fasteners, bolts, nuts
- IP66 damper motors designed for swimming pool use
- Large inspection doors with strong hinges and tongue locks and handles for easy access for service
- Modular unit for easy and quick installation with all sensors and electrical components already connected
Separate control panel fitted with cables and plugs for quick electrical connection between unit and panel
- BMS communication with either Modbus or BACnet

Specifications	Units	2/4 XKS	3/6 XKS	5/10 XKS	7/14 XKS	9/18 XKS	12/24 XKS	16/32 XKS
Nominal air volume	m ³ /h	3,350	4,500	8,400	12,500	15,500	21,500	25,500
Max. air volume	m ³ /h	4,500	6,000	10,000	14,000	20,000	26,000	32,000
Outdoor air volume	%	0-100	0-100	0-100	0-100	0-100	0-100	0-100
Dehumidification capacity VDI 2089*	kg/h	22	29	54	81	100	139	165
Max. power consumption**	kW	2.2	3.0	6.0	11.0	15.0	22.0	60.0
Power supply	V/Hz	400/3ph/50	400/3ph/50	400/3ph/50	400/3ph/50	400/3ph/50	400/3ph/50	400/3ph/50
Height	mm	1600	1960	1960	2120	2250	2760	3010
Width	mm	3101	3572	3572	3712	4080	4270	5100
Depth	mm	880	880	1400	1900	1800	2200	2200
Weight	kg	850	925	1300	1675	1925	2550	3300

* at 30°C/54% indoor, ** at nominal air volume

DANX XKS



Dimensions (mm)

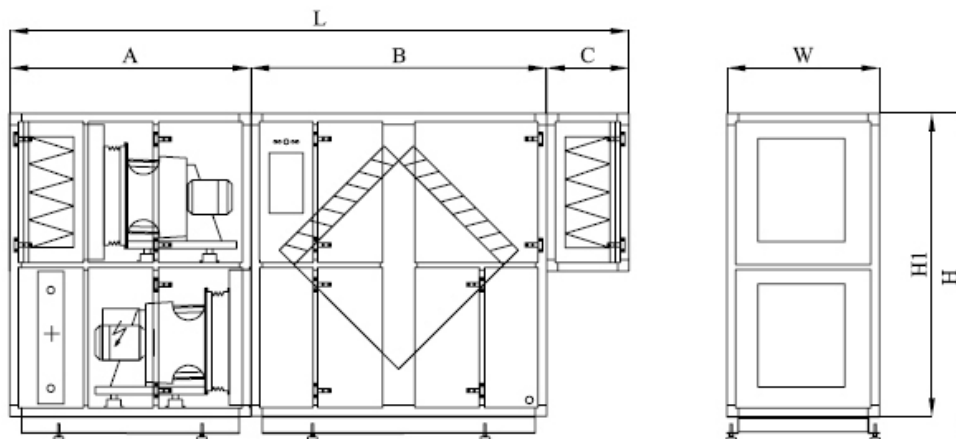

DanX XKS	A mm	B mm	C mm	L mm	W mm	H mm	H1 mm	Weight kg
2/4	1285	1341	475	3101	880	1600	1400	850
3/6	1390	1707	475	3572	880	1960	1760	925
5/10	1390	1707	475	3572	1400	1960	1760	1300
7/14	1530	1707	475	3712	1900	2120	1920	1675
9/18	1685	1920	475	4080	1800	2550	2350	1925

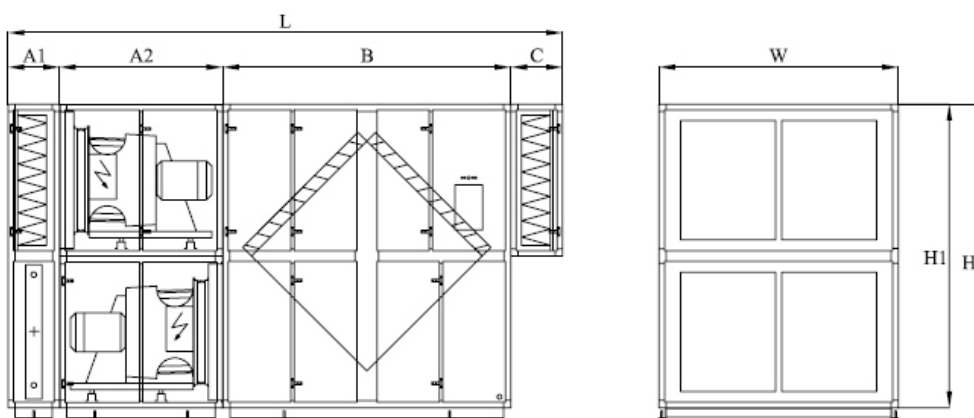

DanX XKS	A mm	A2 mm	B mm	C mm	L mm	W mm	H mm	H1 mm	Weight kg
12/24	475	1400	1920	475	4270	2200	2760	2550	2550
16/32	475	1500	2650	475	5100	2200	3010	2800	3300

DANX CF



DANX CF

The DanX CF is a very effective outdoor air dehumidification system with a highly efficient counter-flow heat exchanger. This system perfectly controls the humidity and indoor temperature while offering significant running cost reductions due to real energy savings of up to 80%. The integrated mixing function ensures that only the exact quantity of outdoor air needed is supplied. This keeps running costs at a minimum.

Free cooling is also an option during summer, when the unit can add up to 100% outdoor air into the pool area through the integrated by-pass.

For countries with high outdoor summer temperatures the system can be equipped with an additional cooling coil for further dehumidification and air cooling.

A wide range of fan types, filter qualities and coils are available on request, enabling you to create the perfect solution for your requirements.



- User-friendly control system for high-quality demand management. Automatic monitoring and control of temperature and humidity of the pool hall
- Counter-flow heat exchangers with a high efficiency of up to 93% and a low pressure drop
- Built-in by-pass for free cooling in the summertime.
- Highly energy-efficient EC plug fans
- Efficient bag filters in different lengths and qualities with low pressure drops are available
- Load-bearing frame construction module with hot-dip galvanised, powder-painted sandwich panels with 50mm mineral wool insulation, internal partition walls with 30mm and bottom frame with adjustable feet
- Designed to withstand the aggressive swimming pool environment (corrosion class C4 according to EN/ISO 12944-2), with epoxy-coated counter-flow heat exchanger, heating coil with aluminium frame, pre-painted fins and epoxy coating to protect all fasteners, bolts, nuts
- Large inspection doors with strong hinges and tongue locks and handles for easy access for service
- Modular unit for easy and quick installation – all sensors and electrical components pre-connected.
- BMS communication with either Modbus or BACnet

DANX CF

Specifications	Units	DANX CF 3/5	DANX CF 4/7	DANX CF 6/9	DANX CF 8/12
Nominal air volume	m ³ /h	3,100	4,400	6,300	8,000
Max air volume	m ³ /h	4,500	6,500	9,000	11,500
Outdoor air volume	%	0-100	0-100	0-100	0-100
Dehumidification capacity VDI 2089*	kg/h	20	29	41	52
Power supply	V/Hz	400/3ph/50	400/3ph/50	400/3ph/50	400/3ph/50
Height	mm	1700	1700	2300	2300
Width	mm	3790	3790	4490	4490
Depth	mm	880	1185	1185	1473
Weight	kg	800	960	1335	1530

Specifications	Units	DANX CF 10/14	DANX CF 12/17	DANX CF 16/23	DANX CF 19/28	DANX CF 22/32
Nominal air volume	m ³ /h	9,800	11,600	16,000	19,000	22,000
Max air volume	m ³ /h	14,000	17,000	23,000	28,000	32,000
Outdoor air volume	%	0-100	0-100	0-100	0-100	0-100
Dehumidification capacity VDI 2089*	kg/h	63	75	104	123	142
Power supply	V/Hz	400/3ph/50	400/3ph/50	400/3ph/50	400/3ph/50	400/3ph/50
Height	mm	2300	2300	3000	3600	3600
Width	mm	4490	4490	4760	4760	4760
Depth	mm	1778	2066	1964	2066	2370
Weight	kg	1730	1950	2365	2685	2755

* at 30°C/54% indoor

DANX CF



Dimensions (mm)

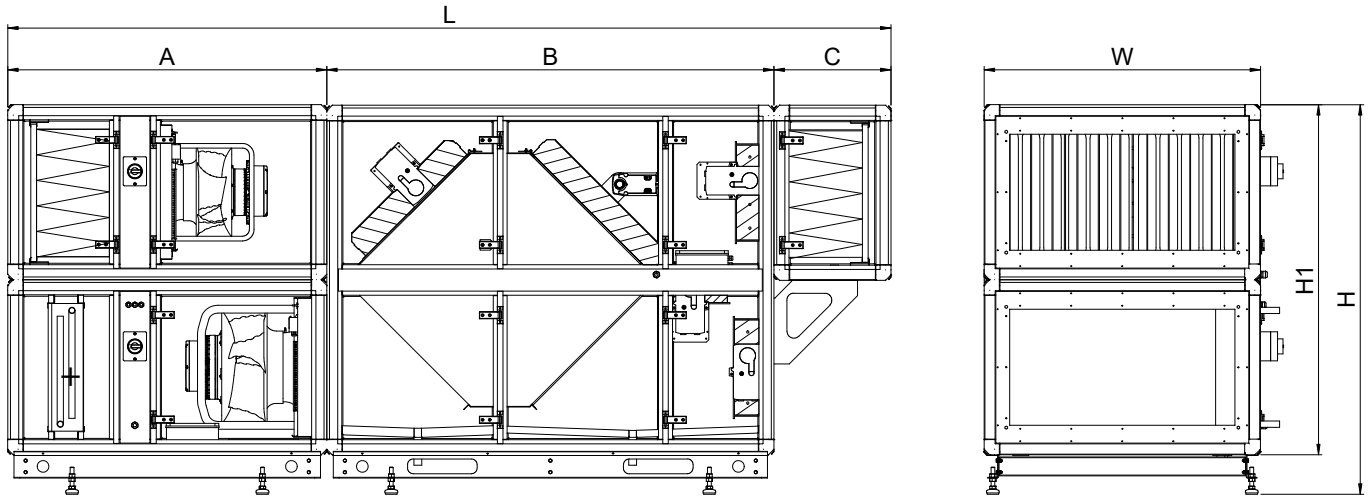

DanX CF	A mm	B mm	C mm	L mm	W mm	H1 mm	H mm	Weight kg
3/5	1370	1920	500	3790	880	1500	1700	800
4/7	1370	1920	500	3790	1185	1500	1700	960
6/9	1490	2500	500	4490	1185	2100	2300	1335
8/12	1490	2500	500	4490	1473	2100	2300	1530
10/14	1490	2500	500	4490	1778	2100	2300	1730
12/17	1490	2500	500	4490	2066	2100	2300	1950
16/23	1490	2770	500	4760	1964	2800	3000	2365
19/28	1490	2770	500	4760	2066	3400	3600	2685
22/32	1490	2770	500	4760	2370	3400	3600	2755

DANX 1-2-3 HP

**DANX 1/2/3 HP****DanX HP with double crossflow heat exchanger and heat pump**

The DanX HP combines the strengths of a heat pump system with a system that dehumidifies using outdoor air. The combined heat pump and highly effective double crossflow heat exchanger precisely regulate both humidity and temperatures in the pool room. In addition to heat recovery exceeding 100% the heat pump optimises dehumidification, so that the proportion of outdoor air never exceeds what is necessary to ensure comfort. For further energy optimization, a water-cooled condenser can be integrated into the heat pump. This allows the excess heat to be transferred to the pool or the hot water supply, where it is reused.

Optional accessories

- Water trap - 092447
- Fire thermostat 40°C/70°C - 101277
- Attendance transmitter - 076092
- Outdoor sensor - 018092
- Frost thermostat for LPHW coil Auto reset - 101953
- Frost thermostat for LPHW coil MAN reset - 102092
- 3.5" control panel, touch screen - 109404

- Built-in heat pump with rotary compressor and high COP Optional built-in water cooled condenser for heating of the pool or domestic water
- Built-in user friendly control system for high-quality demand management Automatic monitoring and control of pool hall temperature and humidity
- Double crossflow heat exchangers with a high efficiency of more than 85% and a low pressure drop
- Built-in by-pass for free cooling in the summertime
- Highly energy-efficient EC plug fans
- Efficient M5/ePM10 70% and F7/ePM1 55% compact filters with low pressure drop
- Self-bearing cabinet with hot-dip galvanised, powder-painted sandwich panels with 50mm mineral wool insulation, internal partition walls with 30mm and bottom frame with adjustable feet
- Designed to withstand the aggressive swimming pool environment (Corrosion class C4 according to EN/ISO 12944-2), with epoxy-coated crossflow heat exchangers, coils with aluminium frame, pre-painted fins and epoxy coating to protect all fasteners, bolts and nuts
- Two large inspection doors with strong hinges and tongue locks and handles for easy access for service
- All-in-one box solutions for easy and quick installation with all sensors and electrical components already connected
- BMS communication with either Modbus or BACnet

Specifications	Units	DANX 1 HP	DANX 2 HP	DANX 3 HP
Nominal air volume	m ³ /h	1,000	1,750	2,750
Max. air volume	m ³ /h	1,300	2,100	3,500
Max. external duct pressure*	Pa	350	350	350
Outdoor air volume	%	0-100	0-100	0-100
Dehumidification capacity recirculation**	kg/h	1.7	4.2	6.9
Dehumidification capacity VDI 2089**	kg/h	7	11	18
Power consumption compressor**	kW	0.6	1.2	1.9
Max. power consumption	kW	1.7	2.9	4.6
Power supply	V/Hz	230/1ph/50	400/2ph/50	400/2ph/50
R407C gas weight/CO ₂ equivalent	kg/t	1.0/1.77	1.6/2.84	4.0/7.10
Product size (w x d x h)	mm	1750 x 515 x 1570	1750 x 780 x 1570	2250 x 890 x 1990
Weight	kg	279	379	500

* at nominal air volume, ** at 30°C/54% indoor

DANX 1-2-3 HP



DanX 1 HP dimensions (mm)

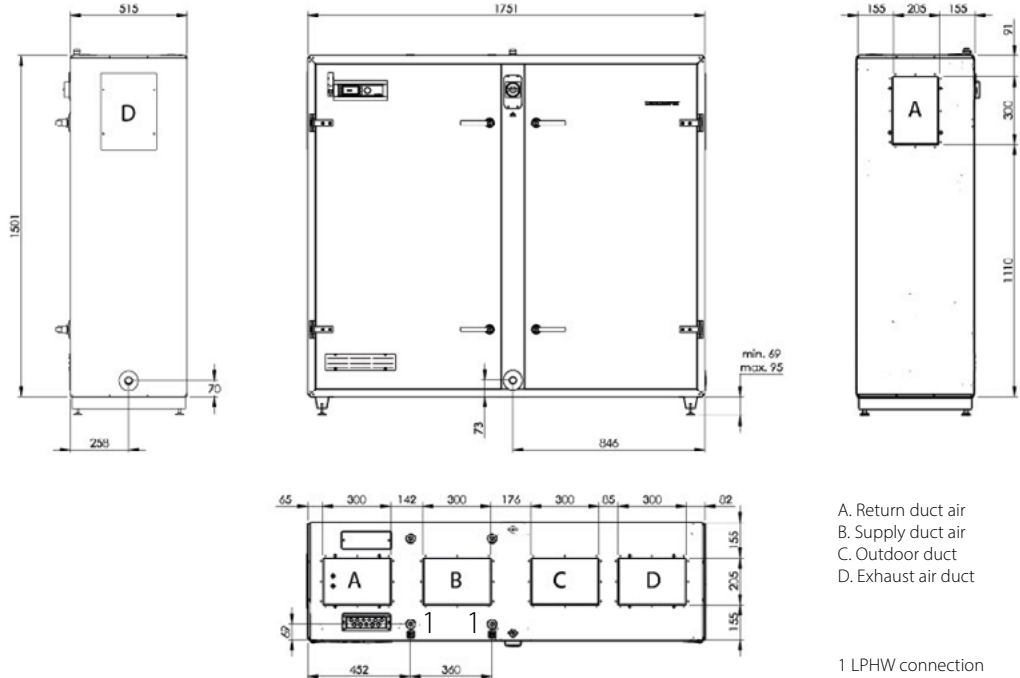

The unit shown in the picture is left hand position.

DanX 2 HP dimensions (mm)

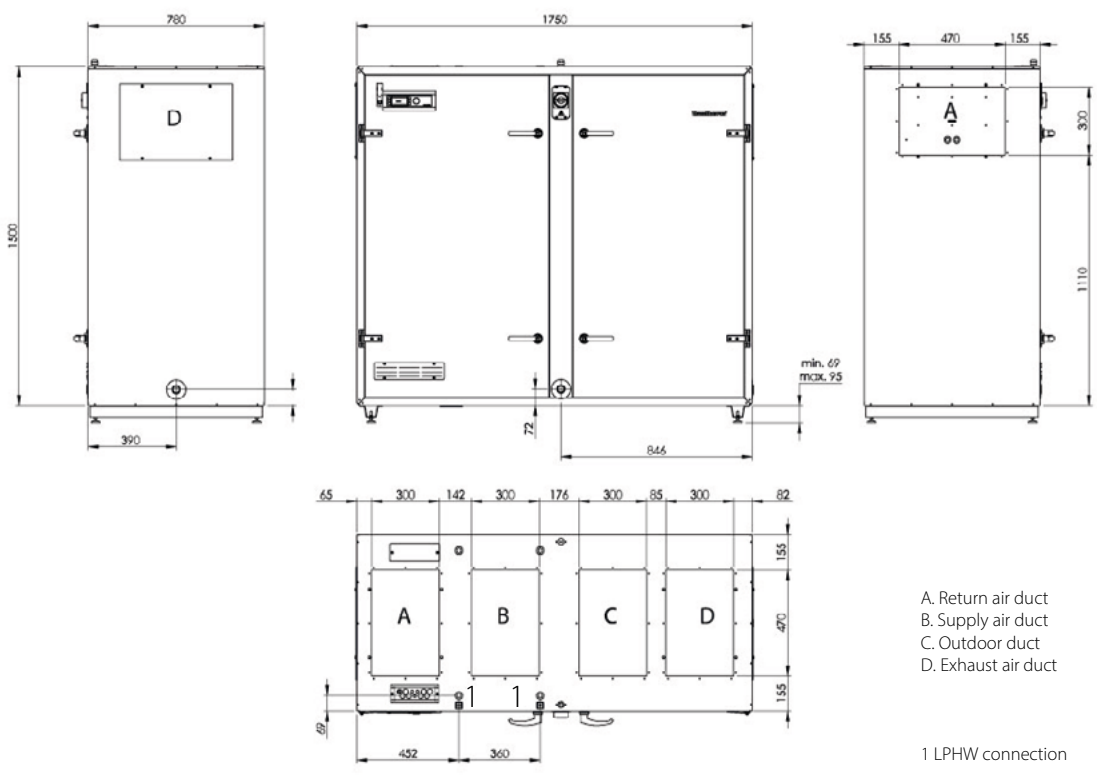

The unit shown in the picture is left hand position.

DANX 1-2-3 HP



DanX 3 HP dimensions (mm)

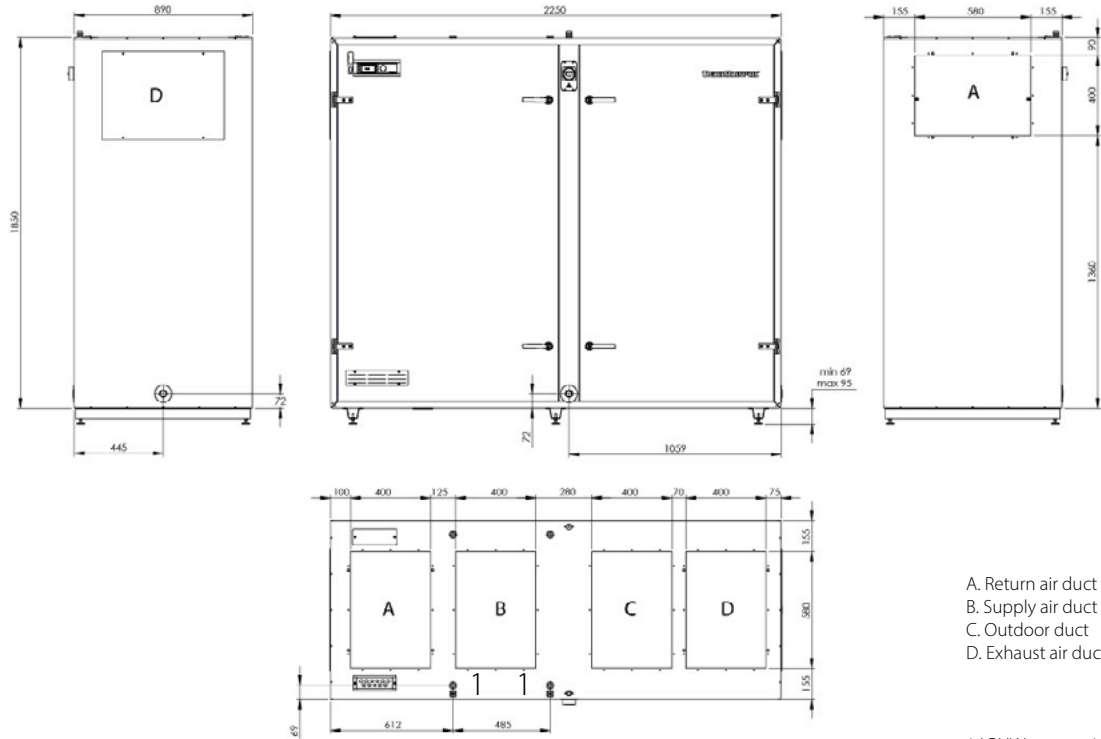

- A. Return air duct
- B. Supply air duct
- C. Outdoor duct
- D. Exhaust air duct

1 LPHW connection

The unit shown in the picture is left hand position.

DANX XWPS



DANX XWPS

DanX XWPS with heat pump and crossflow heat exchanger

The DanX XWPS combines the best of heat pumps and outside air dehumidification systems. The combination of heat pump and a efficient crossflow heat exchanger with an efficiency that exceeds 75% enables you to take full control of both humidity and indoor temperature.

Significant running cost reductions due to energy savings may exceed 100%.

The integrated mixing function ensures that only the exact quantity of outdoor air required to sustain comfortable conditions is supplied.

- Built-in heat pump with scroll compressor and high COP
Optional built-in water-cooled condenser for heating of pool or domestic water
- User-friendly control system for high-quality demand management Automatic monitoring and control of pool hall temperature and humidity
- Very efficient crossflow heat exchanger
- Built-in by-pass for free cooling in the summertime
- Highly energy-efficient EC plug fans
- Efficient bag filters in different lengths and qualities with low pressure drops are available
- Load-bearing frame construction module with hot-dip galvanised, powder-painted sandwich panels with 50mm mineral wool insulation, internal partition walls with 30mm and bottom frame with adjustable feet
- Designed to withstand the aggressive swimming pool environment (Corrosion class C4 according to EN/ISO 12944-2), with epoxy-coated crossflow heat exchanger, coils with aluminium frame, pre-painted fins and epoxy coating to protect all fasteners, bolts and nuts
- IP66 damper motors designed for pool environments
- Large inspection doors with strong hinges and tongue locks and handles for easy access for service
- Modular unit for easy and quick installation with all sensors and electrical components already connected
- BMS communication with either Modbus or BACnet

Specifications	Units	2/4 XWPS	3/6 XWPS	5/10 XWPS	7/14 XWPS	9/18 XWPS	12/24 XWPS	16/32 XWPS
Nominal air volume	m ³ /h	3,350	4,500	8,400	12,500	15,500	21,500	25,500
Max. air volume	m ³ /h	4,500	6,000	10,000	14,000	20,000	26,000	32,000
Outdoor air volume	%	0-100	0-100	0-100	0-100	0-100	0-100	0-100
Dehumidification capacity recirculation*	kg/h	9	16	24	31	40	64	71
Dehumidification capacity VDI 2089*	kg/h	22	29	54	81	100	139	165
Max. power consumption compressor	kW	4.4	5.7	8.8	12.0	16.0	24.0	30.0
Max. power consumption**	kW	7.4	10.1	16.8	23.0	31.0	46.0	60.0
Power supply	V/Hz	400/3ph/50	400/3ph/50	400/3ph/50	400/3ph/50	400/3ph/50	400/3ph/50	400/3ph/50
R407C gas weight/CO ₂ equivalent	kg/t	9/15.97	11/19.51	13/23.06	15/26.61	20/35.48	25/44.35	30/53.22
Height	mm	1600	1960	1960	2120	2250	2760	3010
Width	mm	3665	4135	4135	4275	4660	4950	5868
Depth	mm	880	880	1400	1900	1800	2200	2200
Weight	kg	1150	1300	1800	2300	2700	3650	4600

* at 30°C/54% indoor, ** at nominal air volume

DANX XWPS



Dimensions

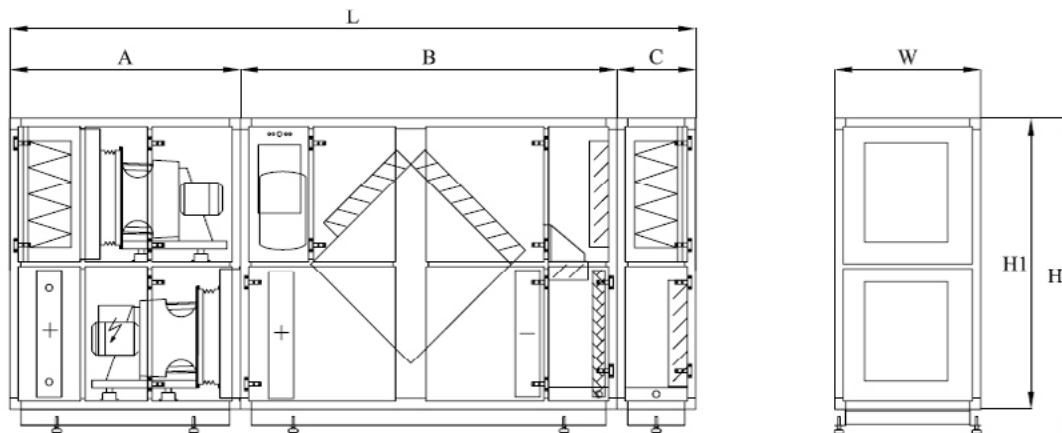

DanX XWPS	A mm	B mm	C mm	L mm	W mm	H mm	H1 mm	Weight kg
2/4	1285	1905	475	3665	880	1600	1400	1150
3/6	1390	2270	475	4135	880	1960	1760	1300
5/10	1390	2270	475	4135	1400	1960	1760	1800
7/14	1530	2270	475	4275	1900	2120	1920	2300
9/18	1685	2500	475	4660	1800	2550	2350	2700

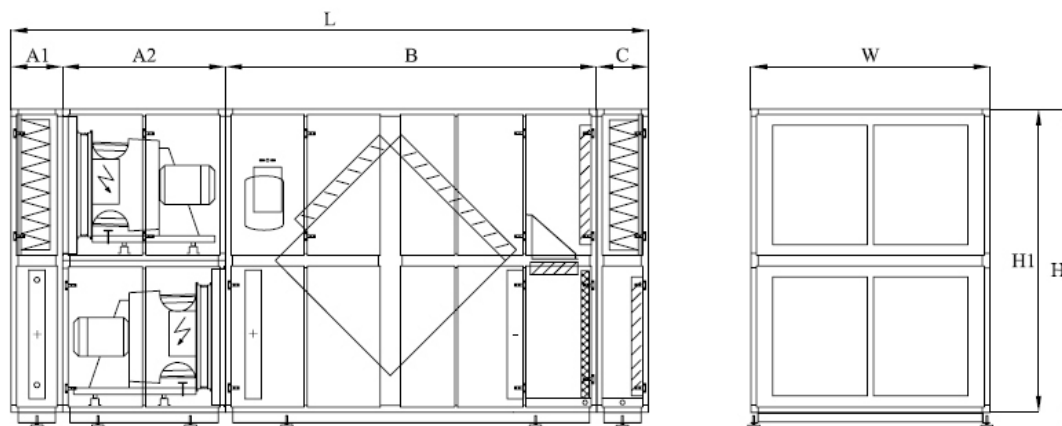

DanX XWPS	A1 mm	A2 mm	B mm	C mm	L mm	W mm	H mm	H1 mm	Weight kg
12/24	475	1400	2600	475	4950	2200	2760	2550	3650
16/32	475	1500	3418	475	5868	2200	3010	2800	4600

DANX XWPRS



DANX XWPRS

DanX XWPRS with reversible heat pump and crossflow heat exchanger

The DanX XWPRS combines the advantages of heat pumps and outside air dehumidification systems. The combination of the heat pump and a efficient crossflow heat exchanger gives you full control of the humidity as well as the indoor temperature. The reversible heat pump offers the possibility of active cooling in the summer.

The potential running cost reductions are significant and may well exceed 100%.

The integrated mixing function ensures that only the exact quantity of outdoor air required to sustain comfortable conditions is supplied.

- Built-in reversible heat pump with scroll compressor and high COP Optional built-in water-cooled condenser for heating of pool or domestic water
- User-friendly control system for high-quality demand management Automatic monitoring and control of pool hall temperature and humidity
- Crossflow heat exchanger with over 75% efficiency
- Built-in by-pass for free cooling in the summertime
- Reversible heat pump for active summer cooling
- Highly energy-efficient EC plug fans
- Efficient bag filters in different lengths and qualities with low pressure drops are available
- Load bearing frame construction module with hot-dip galvanised, powder-painted sandwich panels with 50mm mineral wool insulation, internal partition walls with 30mm and bottom frame with adjustable feet
- Designed to withstand the aggressive swimming pool environment (Corrosion class C4 according to EN/ISO 12944-2), with epoxy-coated crossflow heat exchanger, coils with aluminium frame, pre-painted fins and epoxy coating to protect all fasteners, bolts and nuts
- IP66 damper motors designed for swimming pool use
- Large inspection doors with strong hinges and tongue locks and handles for easy access for service
- Modular unit for easy and quick installation with all sensors and electrical components already connected
- BMS communication with either Modbus or BACnet

Specifications	Units	2/4 XWPRS	3/6 XWPRS	5/10 XWPRS	7/14 XWPRS	9/18 XWPRS	12/24 XWPRS	16/32 XWPRS
Nominal air volume	m ³ /h	3,350	4,500	8,400	12,500	15,500	21,500	25,500
Max. air volume	m ³ /h	4,500	6,000	10,000	14,000	20,000	26,000	32,000
Outdoor air volume	%	0-100	0-100	0-100	0-100	0-100	0-100	0-100
Dehumidification capacity recirculation*	kg/h	9	16	24	33	43	68	81
Dehumidification capacity VDI 2089*	kg/h	22	29	54	81	100	139	165
Max. power consumption compressor	kW	4.4	5.7	8.8	12.0	16.0	24.0	30.0
Max. total power consumption**	kW	7.4	10.1	16.8	23.0	31.0	46.0	60.0
Power supply	V/Hz	400/3ph/50	400/3ph/50	400/3ph/50	400/3ph/50	400/3ph/50	400/3ph/50	400/3ph/50
R407C gas weight/CO ₂ equivalent	kg/t	9/15.97	11/19.51	13/23.06	15/26.61	20/35.48	25/44.35	30/53.22
Height	mm	1600	1960	1960	2120	2250	2760	3010
Width	mm	3665	4135	4135	4275	4660	4950	5868
Depth	mm	880	880	1400	1900	1800	2200	2200
Weight	kg	1150	1300	1800	2300	2700	3650	4600

* at 30°C/54% indoor, ** at nominal air volume

DANX XWPRS

Dimensions

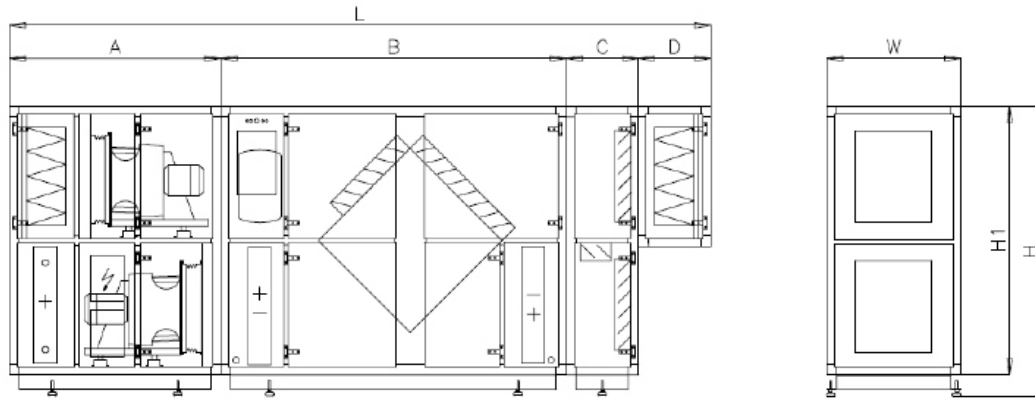

DanX XWPRS	A mm	B mm	C mm	D mm	L mm	W mm	H mm	H1 mm	Weight kg
2/4	1285	2270	475	475	4140	880	1600	1400	1215
3/6	1390	2270	475	475	4610	880	1960	1760	1420
5/10	1390	2270	475	475	4610	1400	1960	1760	1925
7/14	1530	2270	475	475	4750	1900	2120	1920	2600
9/18	1685	2500	600	475	5260	1800	2550	2350	2910

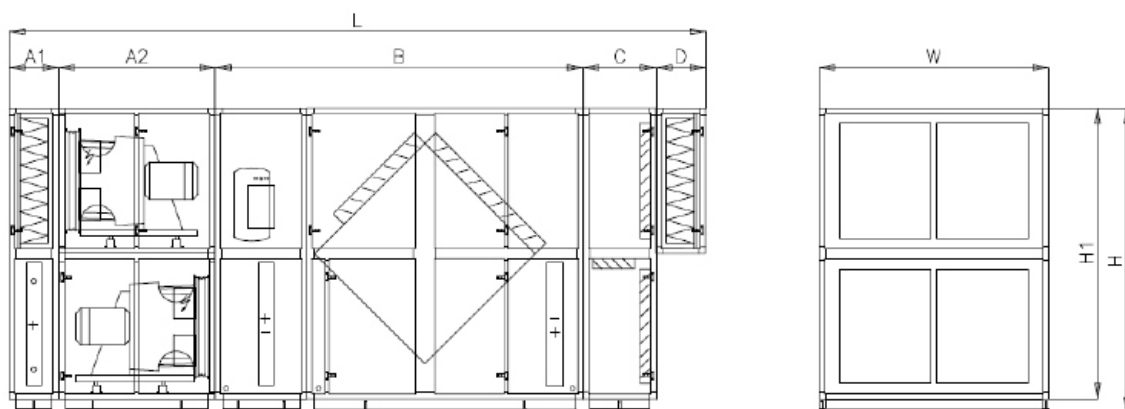

DanX XWPRS	A mm	B mm	C mm	D mm	L mm	W mm	H mm	H1 mm	Weight kg
12/24	475	1400	2600	600	475	2200	2760	2550	3990
16/32	475	1500	3530	700	475	2200	3010	2800	4940



DELTA 4

The Delta range are sophisticated air handling units incorporating hybrid heat pump and fresh air dehumidification technology. With dynamic heat recovery to swimming pool water and air using a heat pump, the Delta is the ultimate solution for a commercial or public indoor swimming pool.



- Dynamic heat pump heat recovery to pool and air
- Self-regulating fresh air control with heat recovery
- Automatic control of exhaust air volume to match pool usage
- Free-cooling (Delta 2)
- Free-cooling and heat pump air cooling (Delta 4-16)
- Integral LPHW heat exchangers for pool and air
- Controllable rpm EC/inverter fans in all models
- PLC control with 5.7" touchscreen user interface
- Remote monitoring/control

Remote monitoring/control

As standard the following remote connectivity is available:

- Screen mirroring to Android/iOS mobile devices using third-party app
- Screen mirroring to web browser with ActiveX
- BMS interfaces for Modbus, BACnet IP and BACnet MS/TP
- Wired remote control interfaces

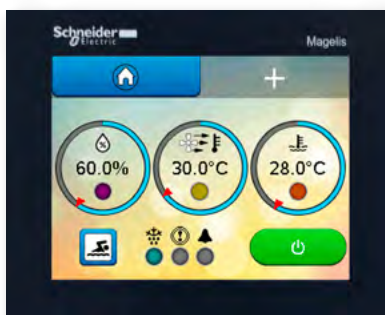

Delta touchscreen controls

How the air flows through the delta

Full dehumidification and heat recovery

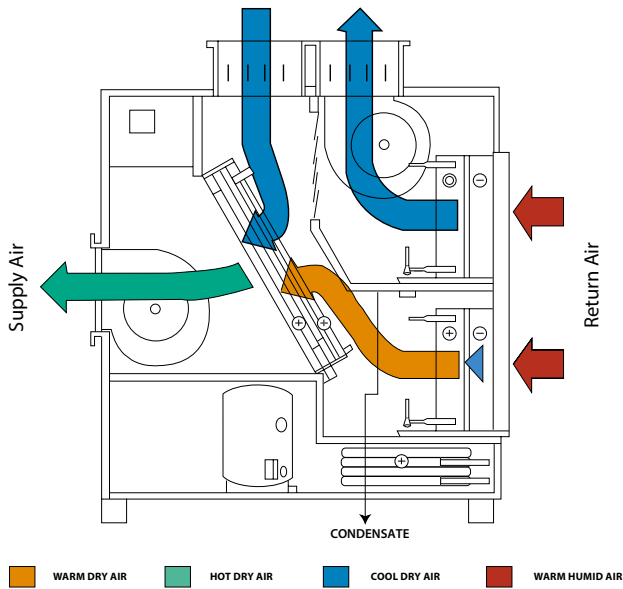

Delta operating on maximum dehumidification of pool air with full heat recovery to pool water and air. Available energy is removed from exhaust air stream. Supplementary heat, if required, supplied by LPHW (water or air).

Light dehumidification and heat recovery

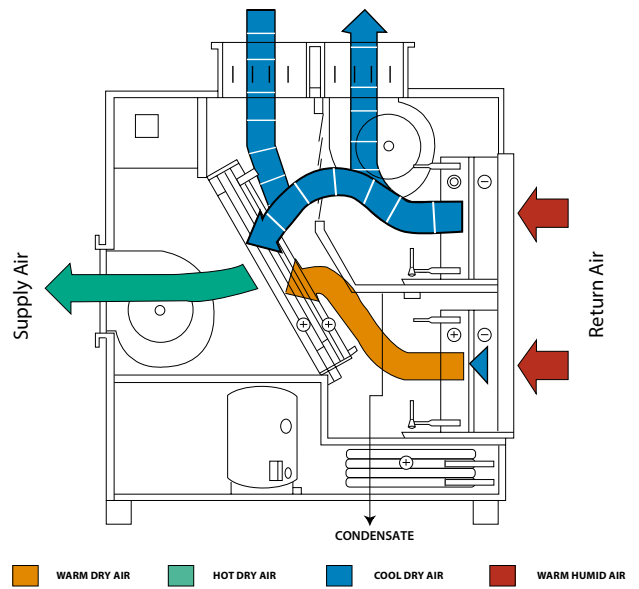

Delta operating on light dehumidification with full heat recovery and reduced fresh air stream – control system automatically selects correct operating mode and damper position. LPHW heat available when required.

Air-conditioning

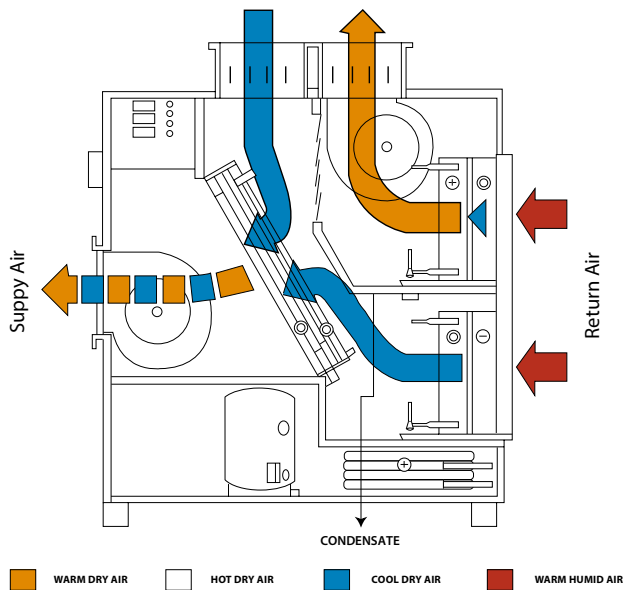

Delta models 4 and above provide an air conditioning facility to minimise the effects of solar gain from larger glazed areas or very high usage. Automatic damper and mode control.

Night set back

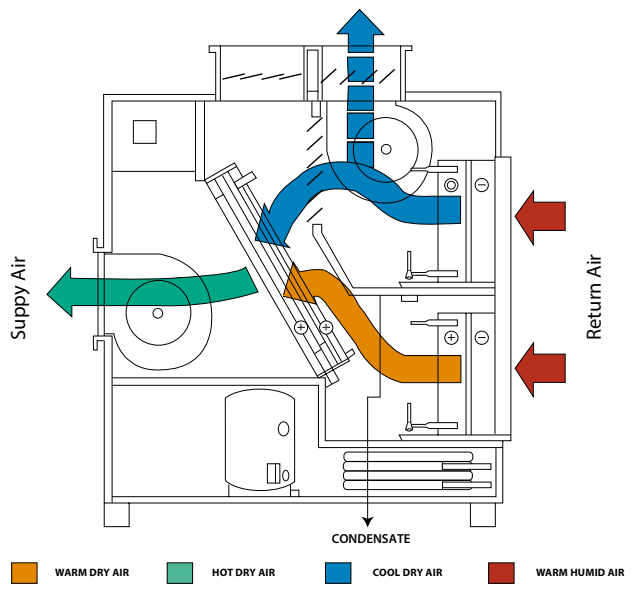

Air temperature set back control is incorporated as standard in all Delta units and controlled by a time clock. Pool hall air is dropped to a lower temperature for maximum economy. Air recirculation is maintained, dampers allow low fresh air flow.

CALOREX DELTA 2-4-6-8-10-12-14-16

Specifications	Units	DT 2	DT 4	DT 6	DT 8	DT 10	DT 12	DT 14	DT 16
Nominal recirculation air flow	m ³ /h	2,600	3,000	4,000	5,000	6,000	7,000	10,000	12,000
Exhaust/fresh air flow (stepped control)	m ³ /h	130-1,300	150-1,500	200-2,000	250-2,500	300-3,000	350-3,500	670-6,700	850-8,000
Total dehumidification @ 28°C/60% RH by heat pump and maximum fresh air	l/h	10.9	12.5	16.6	20.8	25.0	29.2	56.5	62.4
Heat to air									
Via heat pump (Mode B)	kW	4.9	5.1	6.6	8.0	10.0	12.1	30.0	35.0
Via standard LPHW @ 80°C	kW	22	25	30	35	38	42	85	90
Via upgraded LPHW @ 55°C	kW	19	21	26	30	32	36	72	77
Total Mode B + standard LPHW	kW	26.9	30.1	36.6	43.0	48.0	54.1	115.0	125.0
Heat to pool water									
Via heat pump (Mode A)	kW	5.5	5.8	8.0	10.0	12.5	15.0	35.0	43.0
Via LPHW @ 80°C	kW	23	33	33	33	40	40	65	65
Via LPHW @ 55°C	kW	11	16	16	16	20	20	32	32
Total Mode A + LPHW	kW	28.5	38.8	41.0	43.0	52.5	55.0	100.0	108.0
Cooling duty									
Total	kW	0	-4.2	-5.5	-6.7	-8.4	-10.1	-23.0	-28.0
Sensible	kW	0	-2.9	-3.9	-4.7	-5.9	-7.1	-13.0	-15.0
Nominal power consumed	kW	2.9	2.9	3.4	4.4	5.9	7.4	12.3	17.0
R407C gas weight/CO ₂ equivalent	kg/t	3.0/5.32	6.0/10.64	7.8/13.84	7.8/13.84	9.0/15.97	8.0/14.19	22.5/38.14	22.5/38.14
Width	mm	1740	1840	1840	1840	1840	1840	2860	2860
Depth	mm	654	704	704	704	854	854	1126	1126
Height	mm	1685	1970	1970	1970	1970	1970	2120	2120
Weight	kg	310	350	360	370	410	460	954	1020

Options

- Delta 2-6 single or three phase
- Delta 8-16 three phase only
- Upgraded LPHW heat exchanger for air heating
- Left-hand or right-hand orientation (Delta 4-16)
- Top, side or bottom supply fan outlet
- Front or rear supply fan outlet (Delta 14-16)
- Rear exhaust and fresh air connections (Delta 14-16)
- Connection for RCU (Delta 16)

CDP 40-50-70



CDP 70

The wall-mounted or floor-standing CDP 40-50-70 condensation dehumidifiers have been designed to blend well with any modern pool interior. Offering energy-efficient and near-silent humidity control, the units were conceived with a view to quality and ease of operation. Combined with highly efficient fans and compressors, the advanced remote control and monitoring options contribute to cost-efficient operation and significant energy savings.



- Low sound level
- Low energy consumption
- Evaporator and condenser coils are epoxy coated
- Metal parts are powder coated before assembly
- Optional remote control
- Integrated control of heating and humidity (ON/OFF)
- BMS Communication (Modbus RS485)
- 230 V connection for exhaust fan, control valve and/or pump
- Continuous/auto fan mode
- Simple troubleshooting by operational parameter visualization

Optional accessories



Wireless remote control DRC1 - 112450



Floor mounting kit - 094322



Water heating coils - 094333, 094334, 094335



Control valve for water heating coil - 094340



Electric heating coils - 094336, 094337, 094338



Exhaust fans - 094339, 094341



External RH/t sensor - 051710

CDP 40-50-70



Dimensions (mm)

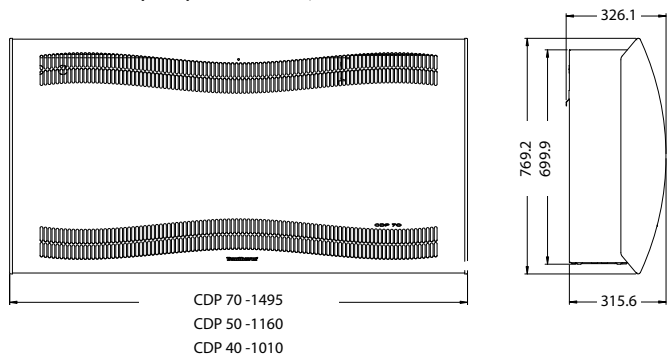

Drain outlet position

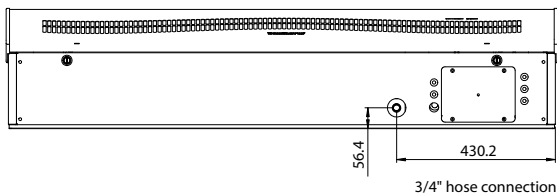

Recommended installation

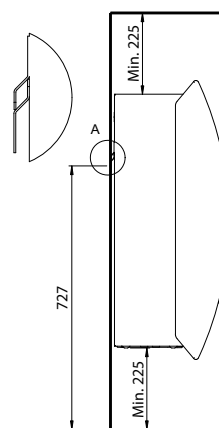

Floor mounting kit

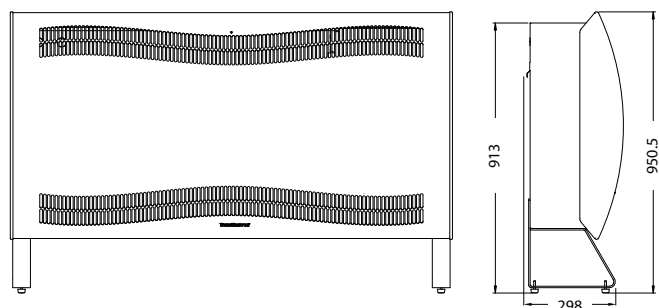

Performance data

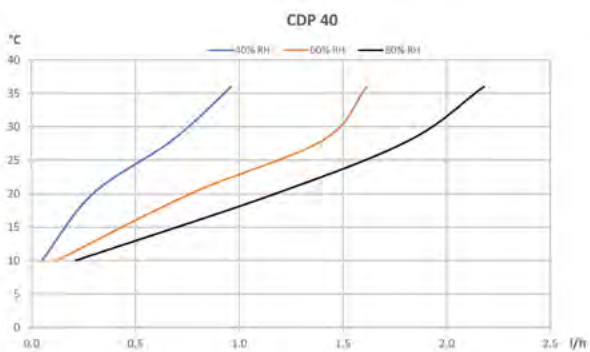

Specific energy consumption (SEC):
0.47 kWh/l at 30°C & 60% RH

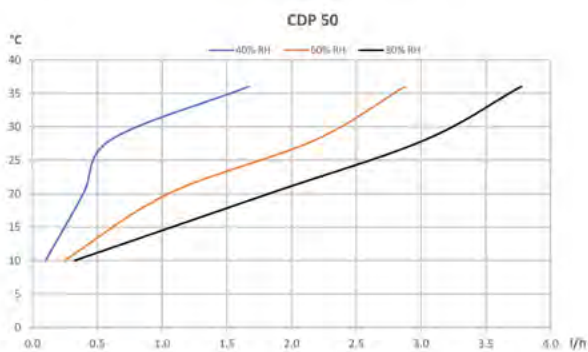

Specific energy consumption (SEC):
0.48 kWh/l at 30°C & 60% RH

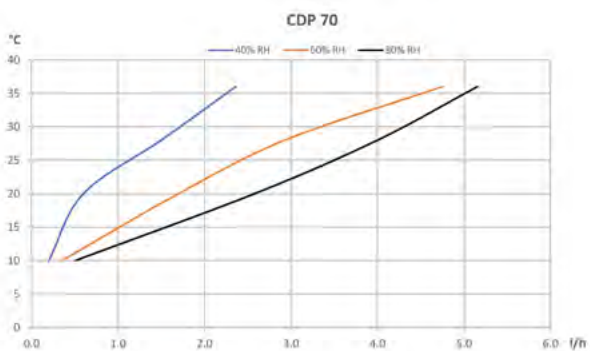

Specific energy consumption (SEC):
0.43 kWh/l at 30°C & 60% RH

CDP 40-50-70

Specifications	Units	CDP 40	CDP 50	CDP 70
Operating temperature range	°C	10-36	10-36	10-36
Operating humidity range	% RH	40-100	40-100	40-100
Dehumidification capacity*	l/24h	35.0	56.5	81.2
Specific Energy Consumption*	kWh/l	0.47	0.48	0.43
Air flow	m ³ /h	400	680	900
Sound pressure level @1m	dB(A)	46	47	50
R407C gas weight/CO ₂ equivalent	kg/t	0.7/1.24	0.9/1.60	1.2/2.13
Power supply	V/Hz	230/1ph/50	230/1ph/50	230/1ph/50
Power consumption*	kW	0.69	1.04	1.24
Power consumption with electric heater*	KW	2.69	4.54	6.24
Heat recovered*	KW	1.97	2.95	4.15
Product size (w x d x h)	mm	1010 x 326 x 770	1160 x 326 x 770	1495 x 326 x 770
Weight	kg	56.5	65.0	75.5

* 30°C/60% RH

CDP 40T-50T-70T



CDP 40T

The CDP 40T-50T-70T condensation dehumidifiers have been designed for through-the-wall mounting in your swimming pool plant room. Designed as highly durable units, the dehumidifiers come with an intuitive user interface and monitoring options for easy operation. Combined with very efficient fans and compressors this secures efficient operation and significant energy savings.



- Low sound level
- Low energy consumption
- Evaporator and condenser coils are epoxy coated
- Metal parts are powder coated before assembly
- Optional remote control
- Integrated control of heating and humidity (ON/OFF)
- BMS Communication (Modbus RS485)
- Continuous/auto fan mode
- Simple troubleshooting by operational parameter visualization

Optional accessories

	<p>Wireless remote control DRC1 - 112450</p>		<p>Through-wall duct kit with filter, extension kit and alu grill - 094271, 094243 093508</p>		<p>Water heating coils - 094333, 094334, 094335</p>		<p>Control valve for water heating coil - 094340</p>
	<p>Electric heating coils - 094336, 094337, 094338</p>		<p>Exhaust fans - 094339, 094341</p>		<p>External RH/t sensor - 051710</p>		<p>Duct lead-in adapter - 094801, 094802 094804</p>

CDP 40T-50T-70T



Specifications	Units	CDP 40T	CDP 50T	CDP 70T
Operating temperature range	°C	10-36	10-36	10-36
Operating humidity range	% RH	40-100	40-100	40-100
Dehumidification capacity*	l/24h	35.0	56.5	81.2
Specific Energy Consumption*	kWh/l	0.47	0.48	0.43
Air flow	m³/h	400	680	900
Max. external pressure loss	Pa	15	15	15
Sound pressure level @1m	dB(A)	43	44	47
R407C gas weight/CO ₂ equivalent	kg/t	0.7/1.24	0.9/1.60	1.2/2.13
Power supply	V/Hz	230/1ph/50	230/1ph/50	230/1ph/50
Power consumption*	kW	0.69	1.04	1.24
Power consumption w/elec. heater*	kW	2.69	4.54	6.24
Heat recovered*	kW	1.97	2.95	4.15
Product size (w x d x h)	mm	998 x 304 x 700	1148 x 304 x 700	1483 x 304 x 700
Weight	kg	57.5	66.0	77.5

* 30°C/60% RH

Dimensions (mm)

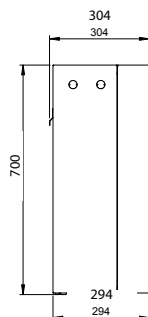
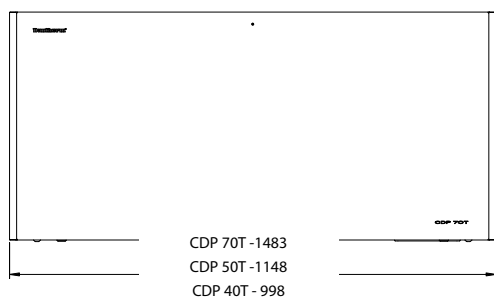

Drain outlet position

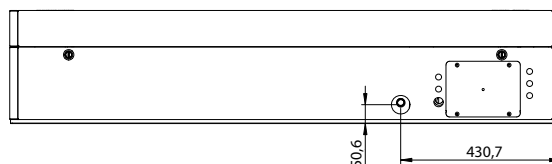

Duct kits

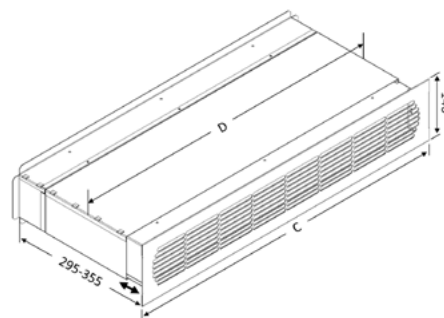
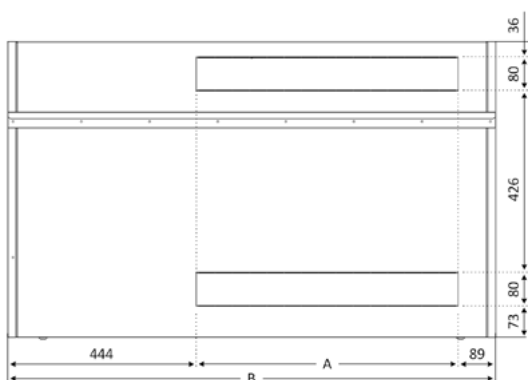

Model	A	B	C	D	Wall opening
CDP 40T	466	998	642	603	610 x 110
CDP 50T	616	1147	791	753	760 x 110
CDP 70T	753	1483	1126	1088	1095 x 110

CDP 40T-50T-70T



Performance data

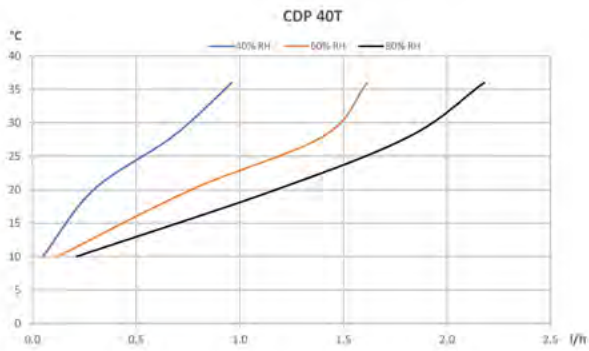

Specific energy consumption (SEC):
0.47 kWh/l at 28°C & 60% RH

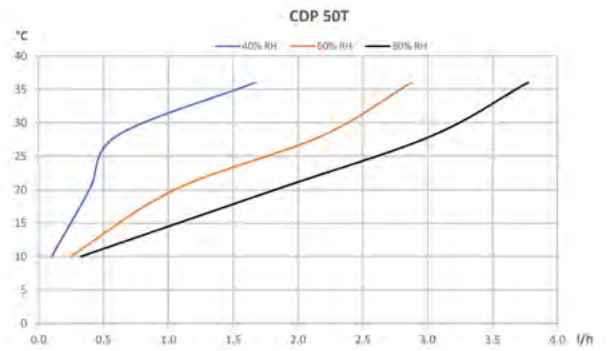

Specific energy consumption (SEC):
0.48 kWh/l at 28°C & 60% RH

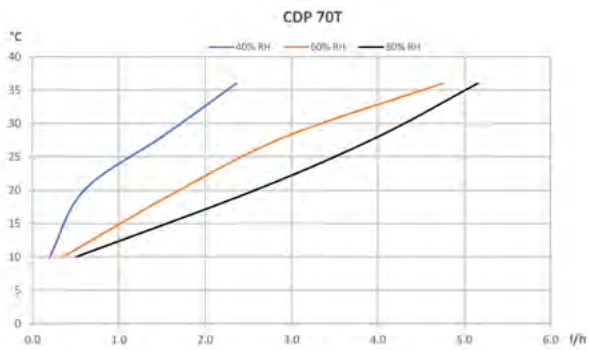

Specific energy consumption (SEC):
0.43 kWh/l at 28°C & 60% RH

Swimming pool dehumidifiers
SET 1501-2501-3501 T

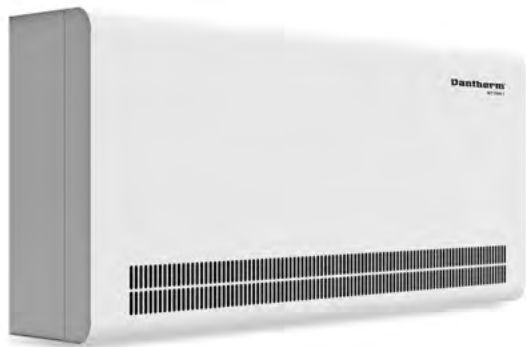

SET 3501 T

The wall-mounted or floor-standing SET 1501-2501-3501 T condensation dehumidifiers are stylish and elegant and have been designed to blend well with any modern pool interior. Offering energy-efficient and near-silent humidity control, the units were conceived with a view to quality and ease of operation. Combined with highly efficient fans and compressors, the advanced remote control and monitoring options contribute to cost-efficient operation and significant energy savings.



- Low sound level
- Low energy consumption
- Evaporator and condenser coils are epoxy coated
- Metal parts are powder coated before assembly
- Optional remote control
- Integrated control of heating and humidity
- BMS Communication (Modbus RS485)
- Available as a through-the-wall version

Optional accessories



Wireless remote control DRC1 - 112450



Water heating coils - 094333, 094334, 094335



Control valve for water heating coil - 094340



Electric heating coils - 094336, 094337, 094338



Exhaust fans - 094339, 094341



External RH/t sensor - 051710

The technical data refer to room at 30°C/60% RH and pool water at 28°C.

Swimming pool dehumidifiers

SET 1501-2501-3501 T

Specifications	Units	SET 1501 T	SET 2501 T	SET 3501 T
Operating temperature range	°C	10-36	10-36	10-36
Operating humidity range	% RH	40-100	40-100	40-100
Dehumidification capacity*	l/24h	34	52	69
Specific energy consumption*	kWh/l	0.51	0.50	0.48
Air flow	m ³ /h	400	680	900
Sound pressure level @ 1m	dB(A)	46	47	50
R407C gas weight/CO ₂ equivalent	kg/t	0.7/1.24	0.9/1.60	1.2/2.13
Power supply	V/Hz	230/1ph/50	230/1ph/50	230/1ph/50
Power consumption*	kW	0.69	1.04	1.24
Power consumption w/elec. heater*	kW	2.69	4.54	6.24
Heat recovered*	kW	1.97	2.95	4.15
Product size (w x d x h)	mm	1004 x 308 x 695	1154 x 308 x 695	1488 x 308 x 695
Weight	kg	56.5	65.0	75.5

* 30°C/54% RH

Dimensions (mm)

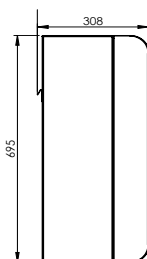
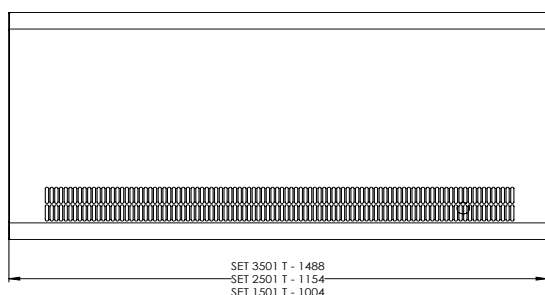

Drain outlet position

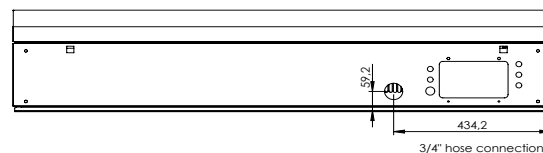

Floor mounting kit

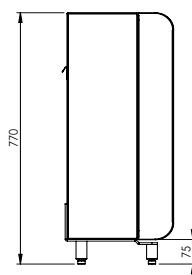
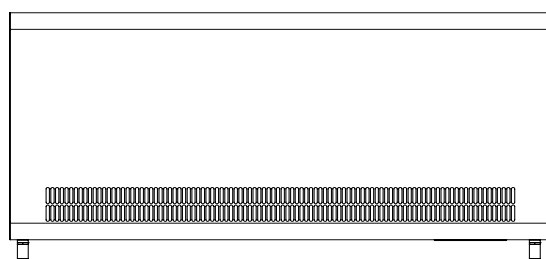

Recommended installation

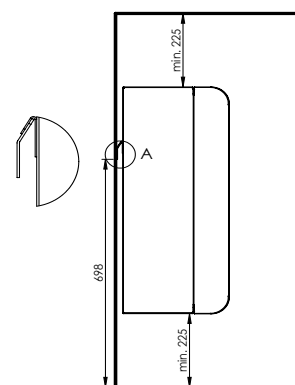

Swimming pool dehumidifiers
SET 1501-2501-3501 T



Performance data

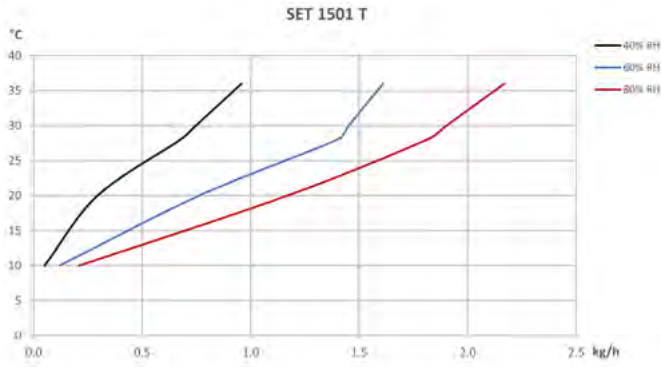

Specific energy consumption (SEC):
 0.47 kWh/l at 30°C & 54% RH

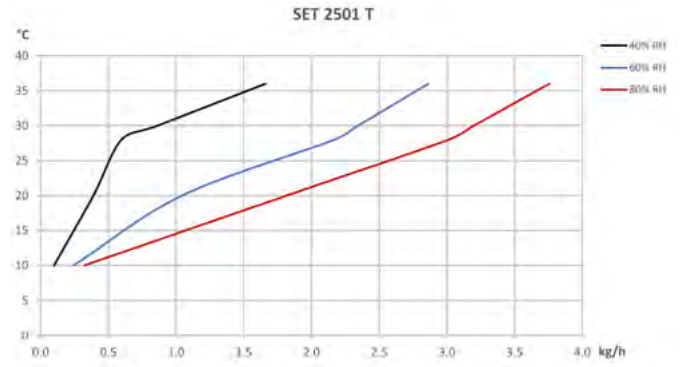

Specific energy consumption (SEC):
 0.48 kWh/l at 30°C & 54% RH

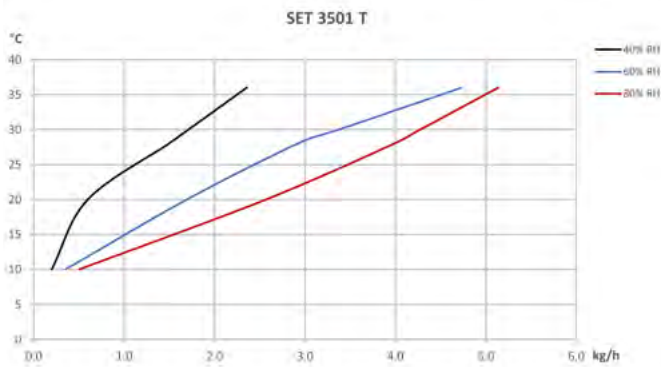

Specific energy consumption (SEC):
 0.43 kWh/l at 30°C & 54% RH

Swimming pool and industrial dehumidifiers

CALOREX DH 75-110 AX/BX



DH 110

DH 75-110 are floor-standing high performance and high capacity dehumidifiers. With high moisture extraction for low energy use, as well as being corrosion free and easy to clean, they are ideal for keeping your swimming pool environment healthy and the humidity under control. Options are also available for additional air heating, and through-the-wall installation that can be situated adjacent to the pool hall.



- High moisture extraction for low power consumption
- Corrosion free, easy to clean aluminium air grille with easy clean air filter
- Low internal operating pressures = long useful life
- Adjustable air outlet
- Quiet centrifugal fans, two speeds
- Hot gas defrost (allows operation to 5°C air temperature)
- Remote humidistat and on/off function

Performance data

DH 75

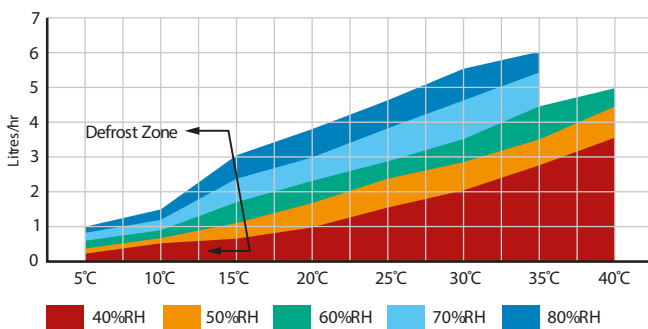

DH 110

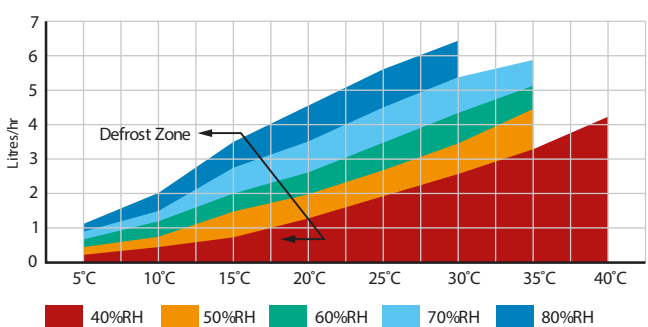

Options

- Through-the-wall version
- LPHW air heater complete with 3 way valve and 12V thermostat interlock
- 400V-3ph option for DH 110

Each unit includes an adjustable humidistat controlling relative humidity (RH) in the ideal range of 55% – 65%. With RH under control, condensation can be minimised by selecting the most appropriate installation from the schematics shown on the next page. Note: vulnerable areas such as windows, roof lights or other cold bridges may form condensation at low external air temperatures unless dry air is blown directly onto them.

Installation options

Floor-standing air flow

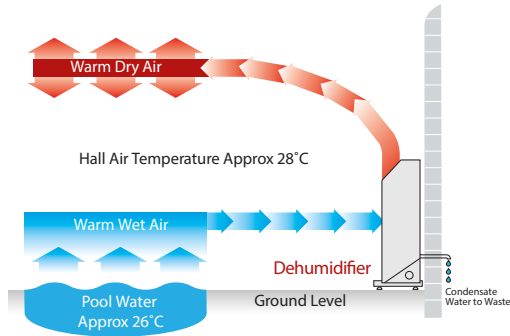

Floor-standing with air heating

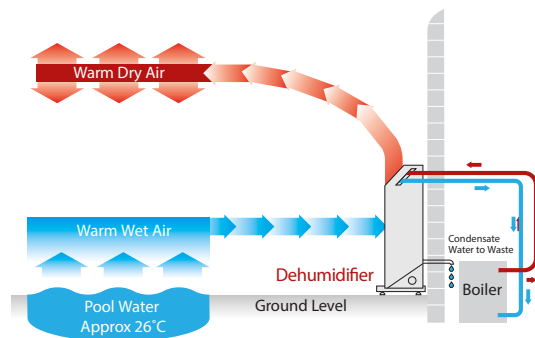

Through-the-wall

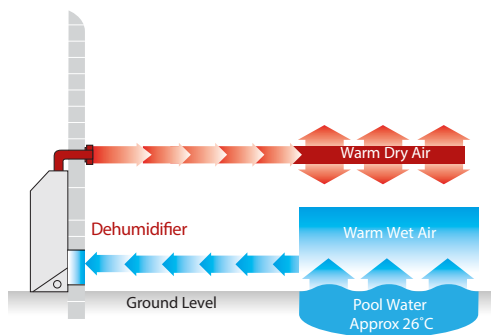

Through-the-wall with air heating

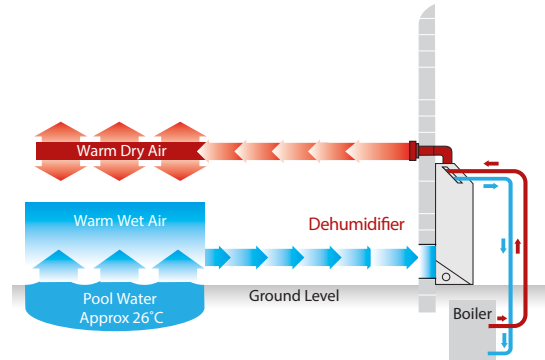

Specifications	Units	DH 75AX	DH 110AX	DH 110BX
Operating temperature range	°C	5-35	5-35	5-35
Dehumidification @ 30°C/60% RH	l/24h	86	108	108
Heat recovered to air @ 30°C/60% RH	kW	4.0	5.2	5.2
Air flow	m³/h	1,180	1,180	1,180
Sound pressure level @ 3m	dB(A)	53	53	53
R407C gas weight/CO ₂ equivalent	kg/t	2/3.55	2/3.55	2/3.55
Power supply	V/Hz	230/1ph/50	230/1ph/50	400/3ph/50
Nominal power consumption	kW	1.5	2.1	2.0
FLA	A	9.5	12.0	5.5
Maximum supply, per phase	A	13	20	10
LRA (compressor start)	A	55	66	30
Heater type		Optional LPHW	Optional LPHW	Optional LPHW
Heater output @ 80°C flow	kW	8.9	8.9	8.9
Flow rate	l/min	9.6	9.6	9.6
Product size (w x d x h)	mm	1520 x 385 x 796	1520 x 385 x 796	1520 x 385 x 796
Weight	kg	143	144	144
Condensate drain size, ID (flexible plastic hose)	mm	15	15	15

DH 120



DH 120

The DH 120 is a powerful condensation dehumidifier designed to manage excess moisture in swimming pool areas as well as commercial and industrial spaces. The floor-standing dehumidifier can remove up to 164.3 litres of moisture per day, effectively controlling humidity levels to prevent mould and mildew growth.

The dehumidifier has been fitted with an easy-to-use control system that lets you set your desired humidity level. It features a durable aluminium housing with cataphoresis-painted coils for corrosion resistance, an electronic humidistat for precise control, and the two fan speed modes Comfort and Boost.

The factory-installed low-pressure hot water heating coil is designed for water temperatures of 55°C.



- Aluminium housing and cataphoresis painted coils for corrosion resistance
- Electronic humidistat for improved humidity control
- Two fan speed modes – Comfort and Boost
- Factory-fitted LPHW heating coil specified for 55°C water temperature
- Designed as a floor-standing unit
- Direct water drainage
- User friendly dashboard
- Modern design
- Easy to install and use
- Modern design

Operational range

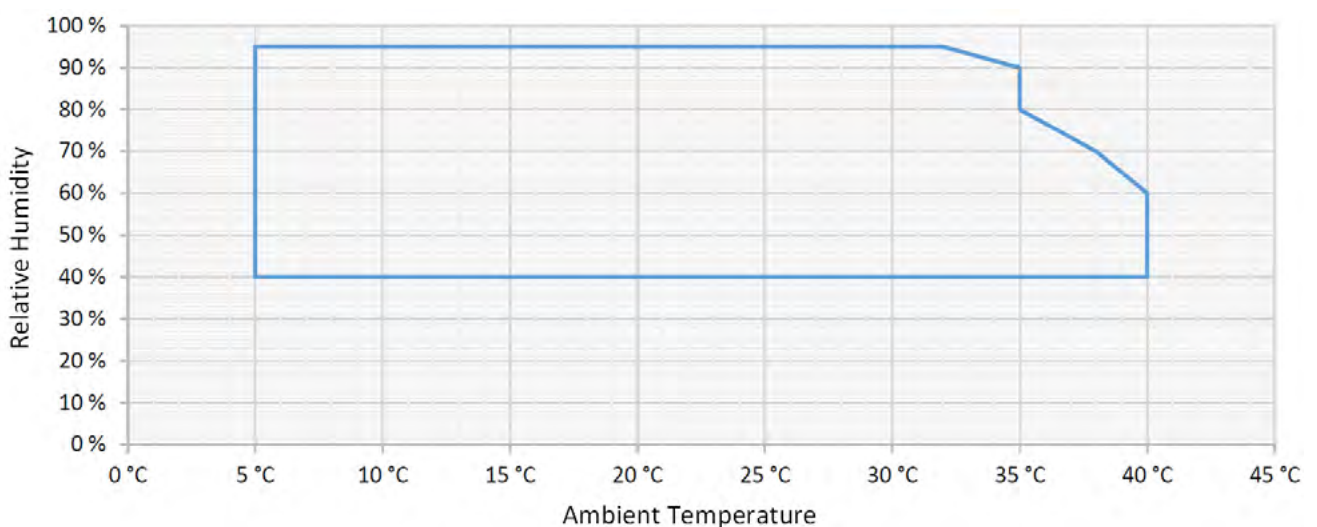

Dehumidification capacity

"Comfort" mode

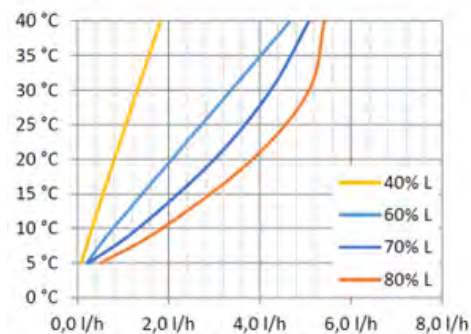

"Boost" mode

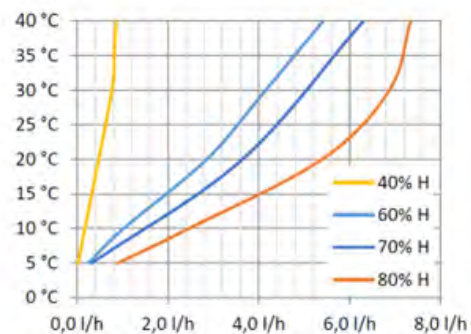

Energy factor

"Comfort" mode

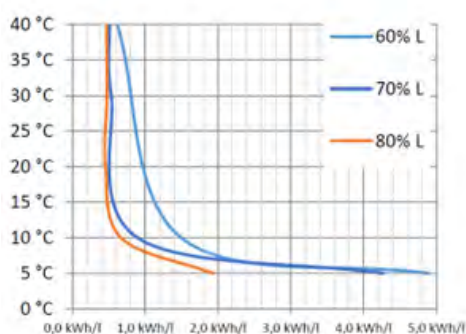

"Boost" mode

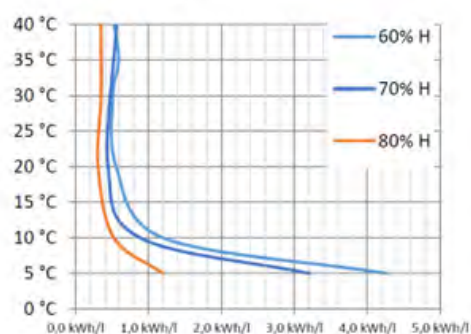

Specifications	Units	DH 120
Operating temperature range	°C	5-40
Operating humidity range	%	40-95
Air flow (comfort / boost)	m ³ /h	800 / 1200
Sound pressure level @ 1 m	dB(A)	51 / 56
Dehumidification capacity*	l/24h	92.5
Dehumidification capacity**	l/24h	66.0
Dehumidification capacity***	l/24h	164.3
Specific Energy Consumption*	kWh/l	0.51
Specific Energy Consumption**	kWh/l	0.56
R454C gas weight/CO ₂ equivalent	kg/t	1.6/0.237
Power supply (incl. E plug and 3 m cable)	V/Hz	230/1ph/50
Power consumption, max	kW	2.6
Current, max.	A	11.7
Product size (W x D x H)	mm	1410 x 365 x 860
Weight	kg/t	130

*30°C/60% RH, **20°C/60% RH ***35°C/80% RH

CDP 85-135-175



CDP 85

The CDP 85-135-175 ducted condensation dehumidifiers are specifically designed for hotel, private, and therapy swimming pool hall dehumidification. They offer a great moisture removal per kWh, high durability, and efficient self-regulation. They are ideal for installation in an adjacent technical room.

All metal parts and internal surfaces are powder coated before assembly and evaporator and condenser coils are made of epoxycoated aluminium. The corrosion protection is in accordance with EN/ISO 12944-2, class C4.

The range is equipped with the Dantherm CC6 controller which comes with an integrated 2.4" touch screen for easy user customisation of setpoints and visualisation of operational variables.

- EC centrifugal constant flow fan
- User specified low and high air volume
- R454C refrigerant with GWP of 148
- Movable inspection access
- Outdoor air inlet possibility (15%) through duct connection
- Supply air duct either horizontally or vertically connected
- Microchannel condenser
- Integrated control of exhaust fan and/or outdoor air damper
- Heat- and cooling demand regulation
- Datalogging and software update via supplied microSD card
- Compact unit designed to suit any plant room configuration
- Sandwich cover panels with 45mm insulation
- Optional water-cooled condenser
- Three setpoint specified control modes – relative, absolute, or dew point
- Modbus RTU (RS485)

Specifications	Units	CDP 85	CDP 135	CDP 175
Operating temperature range	°C	15-38	15-38	15-38
Operating relative humidity range	% RH	40-95	40-95	40-95
Air flow, nominal	m ³ /h	1,500	2,500	3,600
Air flow, range	m ³ /h	550-1,500	1,200-2,500	1,500-3,600
Dehumidification capacity @ 30°C/60% RH	l/24h	88	155	170
Dehumidification capacity @ 20°C/60% RH	l/24h	56	75	100
Dehumidification capacity @ 30°C/60% RH***	l/24h	126	222	261
Specific Energy Consumption (SEC)*	kWh/l	0.38	0.39	0.45
Specific Energy Consumption (SEC)**	kWh/l	0,58	0,58	0,67
Max. external pressure loss	Pa	300	350	450
R454C gas weight/CO ₂ equivalent	kg/t	1.2/0.18	1.5/0.22	1.7/0.25
Power supply	V/Hz	230/1ph/50	230/1ph/50 400/3ph/50	400/3ph/50
Power consumption, nominal air flow	kW	1.9	3.3	4.6
Current, max.	A	8.8	16.1 5.7	9.1
@ 20°C/60%	kW	1.3	1.9	2.6
@ 30°C/60%	kW	1.4	2.8	3.2
Maximum	kW	1.9	3.3	4.6
Product size (w x d x h)	mm	1,155 x 725 x 650	1,300 x 900 x 850	1,400 x 1,010 x 975
Weight (w/o water-cooled condenser)	kg	140	230	240
Colour		RAL 9016	RAL 9016	RAL 9016

*30°C/60% RH @ nominal airflow **20°C/60% RH @ nominal airflow ***15% outdoor air w/ 9.0 g/kg

CDP 85-135-175



Performance data

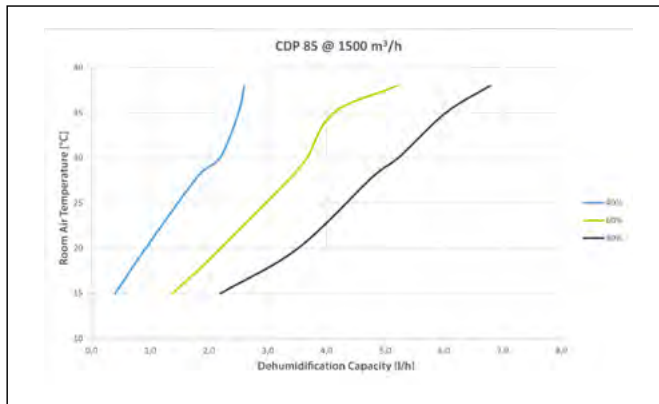

Accessories

- Heating coil water, internal
- Remote controller, wireless
- 2 way valve
- Valve actuator
- Temp/RH sensor, 10 meter cable
- Anti-vibration stands
- Wall brackets

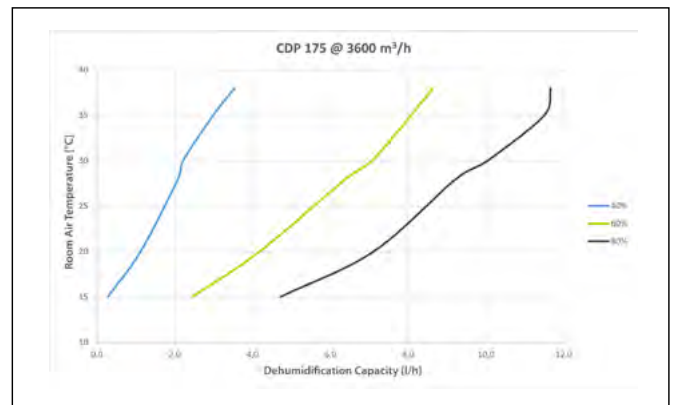
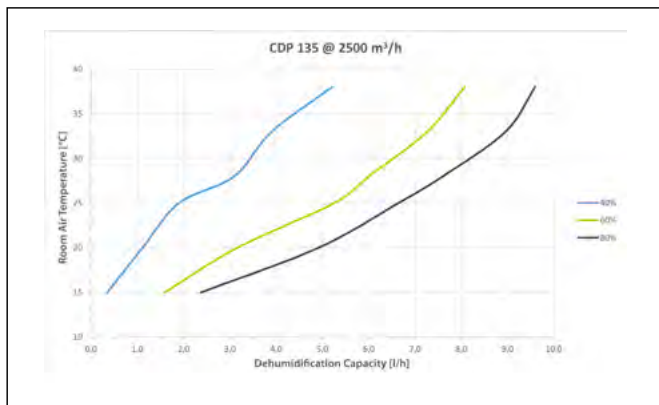

Product dimensions

CDP 85

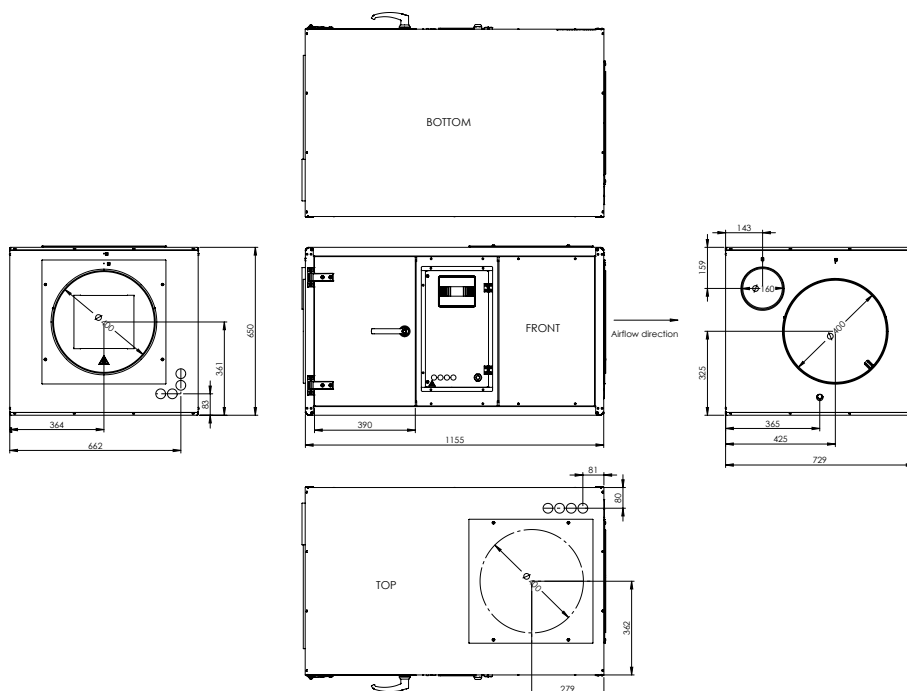

CDP 85-135-175



CDP 135

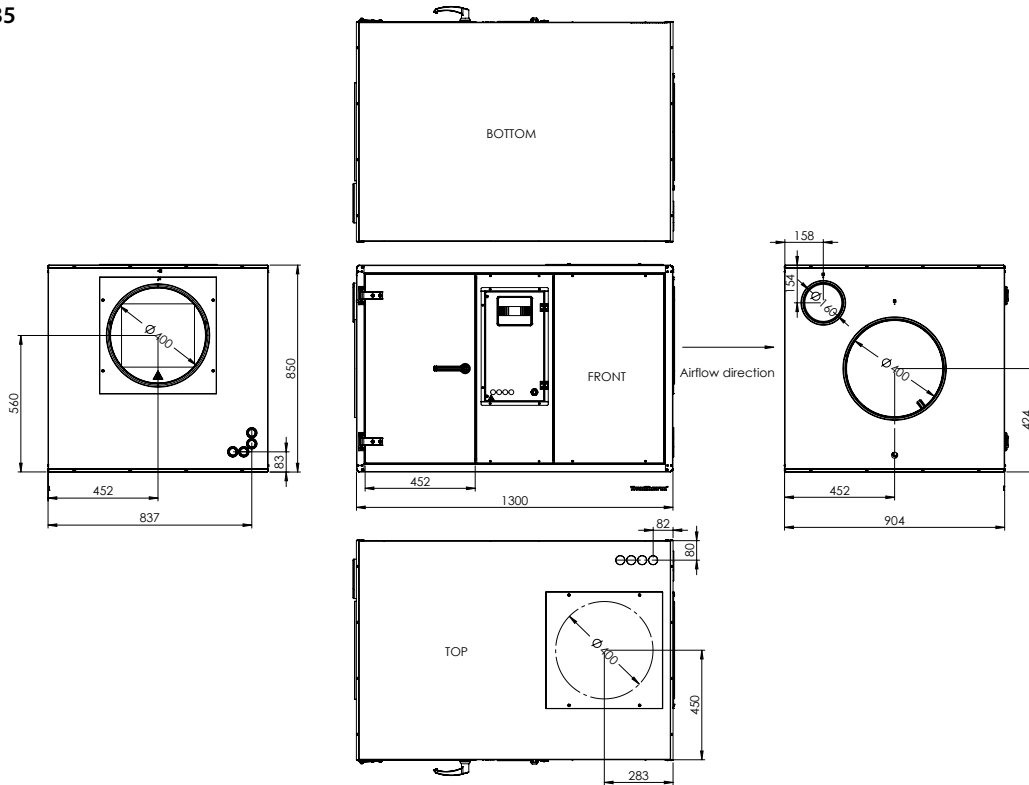

CDP 175

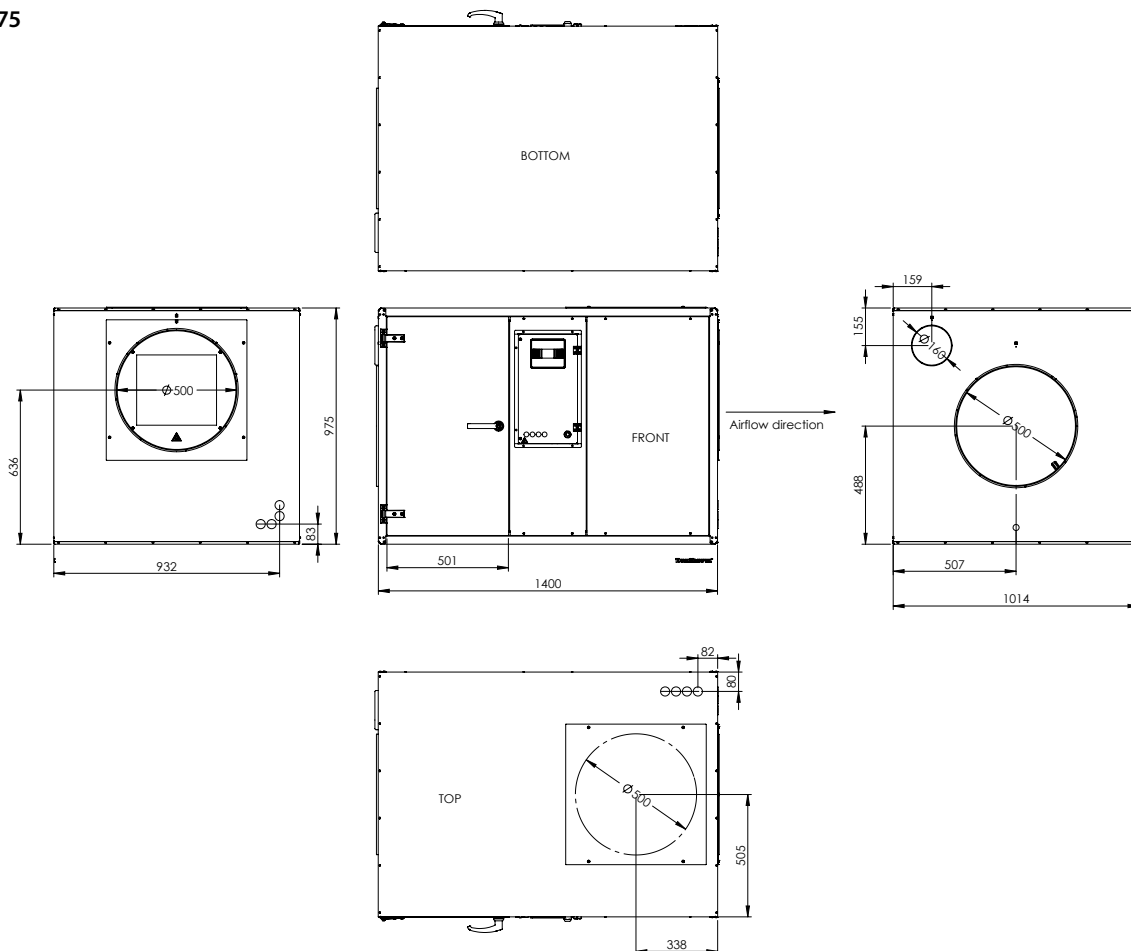



AW 1200



- Pool hall dehumidification
- Dynamic heat pump heat recovery to pool and air
- Constant flow EC fan (models 600, 900, 1200)
- Speed controllable EC fan (model 1500)
- PLC control with 3.5" touchscreen user interface
- Remote monitoring/control

AA+LPHW models add:

- Integral LPHW heat exchanger for air heating

AW models add:

- Dynamic heat pump heat recovery to pool and air
- Integral LPHW heat exchangers for pool and air

The Variheat range are sophisticated air handling units incorporating heat pump dehumidification technology. With dynamic heat recovery using a heat pump, the Variheat is the essential choice for a domestic or light commercial indoor swimming pool. Over 3000 configurations offer the ultimate flexibility for tight plant room spaces. This range is purposely designed for swimming pool climate control, providing the necessary comfort, moisture related structural protection and economical operation.

Options

- Fresh air module
- Upgraded LPHW heat exchanger for air
- Electric resistance air heaters (6/12/18kW)

Electrical heater option notes

- In lieu of LPHW heat exchangers
- 6kW or 12kW is available for 600 and 900 models
- 12kW or 18kW is available for 1200 and 1500 models



Variheat touchscreen controls

The Variheat range are sophisticated air handling units incorporating heat pump dehumidification technology. With dynamic heat recovery using a heat pump, the Variheat is the essential choice for a domestic or light commercial indoor swimming pool.

Installation options

Top outlet

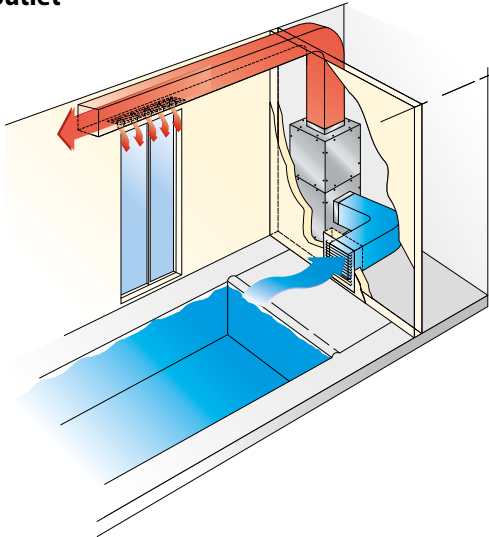

Bottom outlet

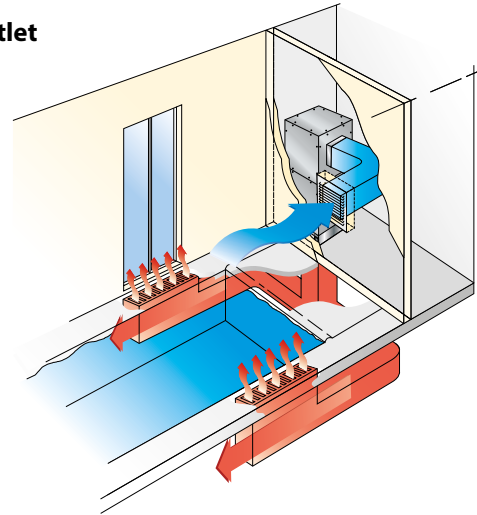

Basement outlet

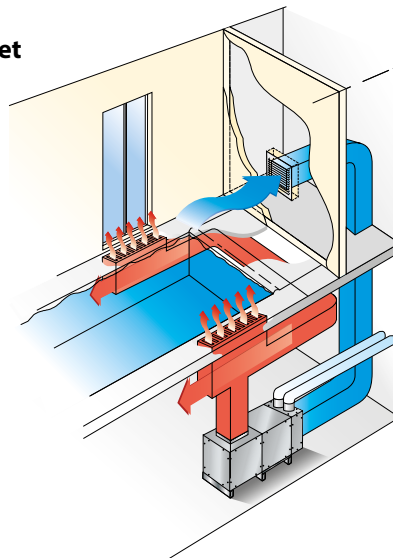

Horizontal outlet

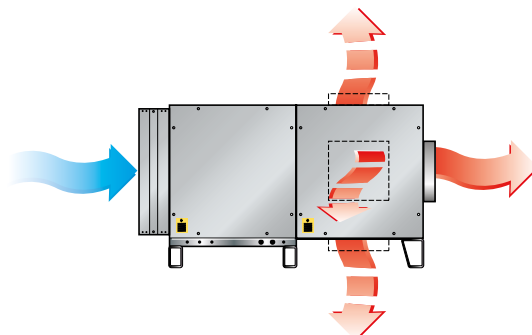

Top outlet

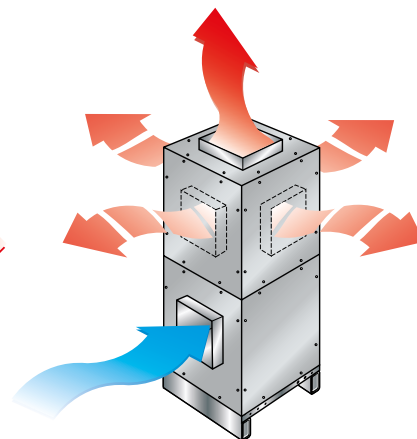

Bottom outlet

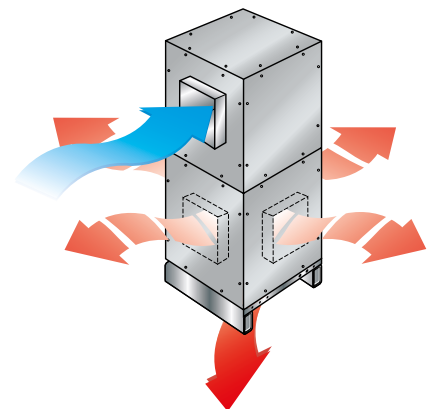

CALOREX VARIHEAT AA/AW 600-900-1200-1500



Configurations

Variheat 600/900

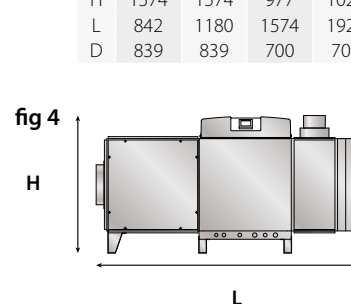
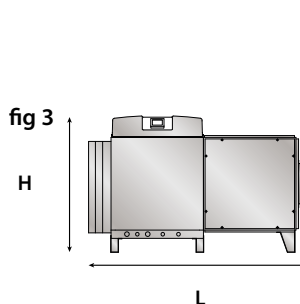
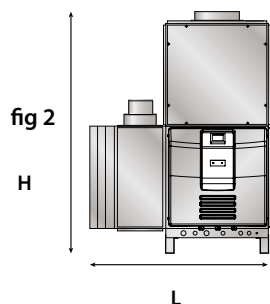
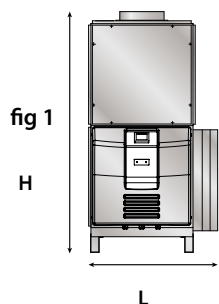

	fig 1	fig 2	fig 3	fig 4
H	1574	1574	977	1028
L	842	1180	1574	1929
D	839	839	700	700

Variheat 1200/1500

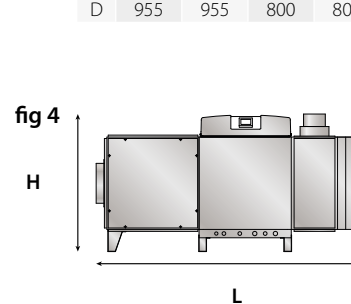
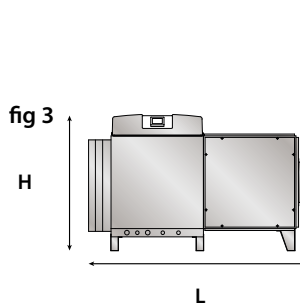
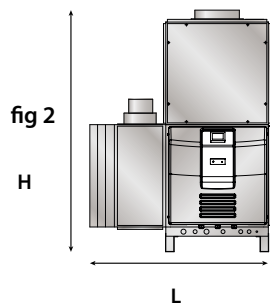
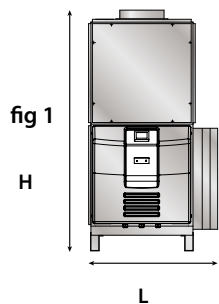

	fig 1	fig 2	fig 3	fig 4
H	1778	1778	1110	1130
L	942	1295	1778	2133
D	955	955	800	800

Example configurations are shown but there are over 3000 configurations available offering the ultimate flexibility for tight plant room spaces. This range is purpose designed for swimming pool climate control, providing the necessary comfort, moisture related structural protection and economical operation.

CALOREX VARIHEAT AA/AW 600-900-1200-1500

Specifications	Units	AW 600	AA 600	AW 900	AA 900	AW 1200	AA 1200	AW 1500	AA 1500
Air flow	m ³ /h	2,000	2,000	2,500	2,500	3,500	3,500	4,300	4,300
External available static pressure	Pa	330	330	220	220	290	290	350	350
Fresh air flow (option)	m ³ /h	0-900	0-900	0-900	0-900	0-900	0-900	0-900	0-900
External available static pressure	Pa	100	100	100	100	100	100	100	100
Dehumidification @ 30°C/60% RH	l/h	4.6	4.6	6.5	6.5	8.5	8.5	10.5	10.5
Dehumidification @ 30°C/70% RH	l/h	5.5	5.5	7.8	7.8	10.8	10.8	13.2	13.2
Heat to air									
Net via heat pump (Mode B)	kW	5.1	5.1	7.1	7.1	10.0	10.0	14.0	14.0
Via standard LPHW @ 80°C	kW	11.0	11.0	13.5	13.5	24.0	24.0	28.0	28.0
Max. available (Mode B + standard LPHW)	kW	14.0	14.0	18.6	18.6	30.0	30.0	36.0	36.0
Via upgraded LPHW @ 55°C	kW	9.4	9.4	11.5	11.5	20.4	20.4	23.8	23.8
Max. available (Mode B + upgraded LPHW)	kW	12.7	12.7	16.9	16.9	27.0	27.0	36.8	36.8
Heat to water									
Net via heat pump (Mode A)	kW	5.5	0	7.4	0	10.0	0	12.5	0
Via LPHW @ 80°C	kW	18.0	0	30.0	0	30.0	0	40.0	0
Max. available (Mode A + LPHW)	kW	23.5	0	37.4	0	40.0	0	52.5	0
Refrigerant		R454C	R454C	R454C	R454C	R407C	R407C	R407C	R407C
Gas weight/CO ₂ equivalent	kg/t	1.8/0.26	1.8/0.26	2.0/0.29	1.85/0.27	2.85/5.06	2.7/4.79	3.0/5.32	2.65/4.70
Nominal power consumed	kW	2.1	2.1	2.8	2.8	2.9/5.14	2.9/5.14	3.0/5.32	3.0/5.32

AW denotes heat recovery to air/water and LPHW heaters for air/water
AA denotes heat recovery to air and optional LPHW heater for air only

DANX AF



DANX AF

The DanX AF is a very effective heat pump dehumidification system, which perfectly controls the humidity and indoor temperature while offering significant running cost reductions. This system is the obvious choice where only limited space is available, or for pools with limited use, for instance hotel pools. Optionally it is also possible to install the unit suspended under the ceiling of the pool room.

For further energy optimization, a water cooled condenser can be integrated into the heat pump. This allows the excess heat to be transferred to the pool or the hot water supply, where it is efficiently reused.

- User-friendly control system that monitors and controls temperature and humidity automatically The custom-built software runs the unit as efficiently as possible under different conditions
- BMS communication with either Modbus or BACnet All internal terminal wiring done from factory
- Refrigerant circuit with optional built-in water cooled condenser for heating of domestic water and external condenser for hot countries
- Optional DX or water-cooling coil
- Highly energy-efficient EC plug fans
- Highly efficient bag filters with a low pressure drop
- Fresh air (30%) inlet possible through fresh air duct
- Load-bearing frame construction module with galvanised, powder-painted sandwich panels with 50mm mineral wool insulation and bottom frame with adjustable feet
- Specifically designed to withstand aggressive environments (Corrosion class C4 according to EN/ISO 12944-2), with epoxy coated coils with aluminium frame, pre-painted fins and with all fasteners, bolts and nuts specially protected
- Large inspection doors with strong hinges and tongue locks and handles for easy access for service
- Modular unit for easy and quick installation with all sensors and electrical components already connected Separate control panel fitted with cables and plugs for quick electrical connection between unit and panel

Specifications	Units	AF 3/6	AF 5/10	AF 5/10s	AF 7/14	AF 7/14s	AF 12/24	AF 12/24s
Operating temperature range	°C	22-36	22-36	22-36	22-36	22-36	22-36	22-36
Operating humidity range	%	50-80	50-80	50-80	50-80	50-80	50-80	50-80
Dehumidification @ 28°C/60% RH	l/h	13	20	25	33	39	52	62
Air flow	m ³ /h	4,850	7,300	9,500	12,000	14,000	19,000	24,000
Available duct pressure	Pa	300	300	300	300	300	300	300
Outdoor air	%	0-30	0-30	0-30	0-30	0-30	0-30	0-30
Power supply	V/Hz	400/3ph/50	400/3ph/50	400/3ph/50	400/3ph/50	400/3ph/50	400/3ph/50	400/3ph/50
R407C gas weight/CO ₂ equivalent	kg/t	9/15.97	14/24.84	14/24.84	22/39.03	22/39.03	32/56.77	32/56.77
Max. power consumption	kW	8.6	12.3	16.1	22.1	24.1	31.7	42.8
Height	mm	1115	1115	1115	1195	1195	1485	1485
Width	mm	3380	3380	3380	3850	3850	4125	4125
Depth	mm	880	1400	1400	1900	1900	2200	2200
Weight	kg	575	800	800	1125	1200	1650	1675

DANX AF



Dimensions (mm)

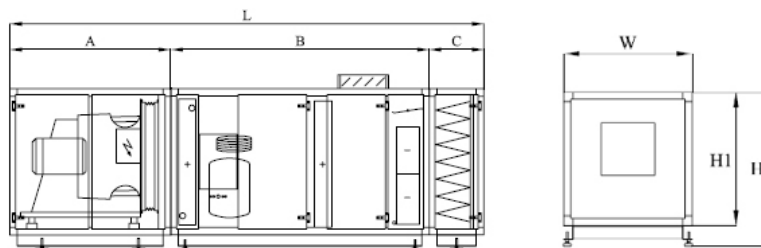

DanX AF	A: mm	B: mm	C: mm	L: mm	W: mm	H: mm	H1: mm	Weight: kg
3/6	985	1920	475	3380	880	1115	915	575
5/10	985	1920	475	3380	1400	1115	915	800
5/10s	985	1920	475	3380	1400	1115	915	800
7/14	1125	2250	475	3850	1900	1195	995	1125
7/14s	1125	2250	475	3850	1900	1195	995	1200
12/24	1400	2250	475	4125	2200	1485	1275	1650
12/24s	1400	2250	475	4125	2200	1485	1275	1675

Performance data

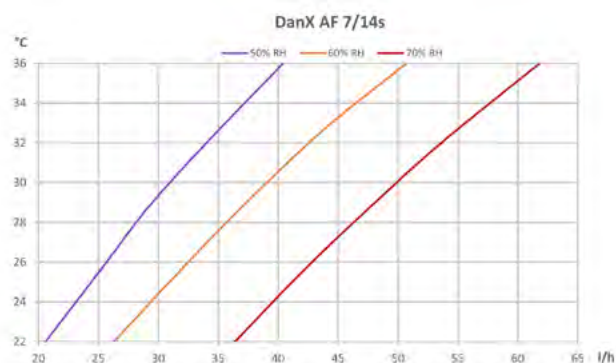
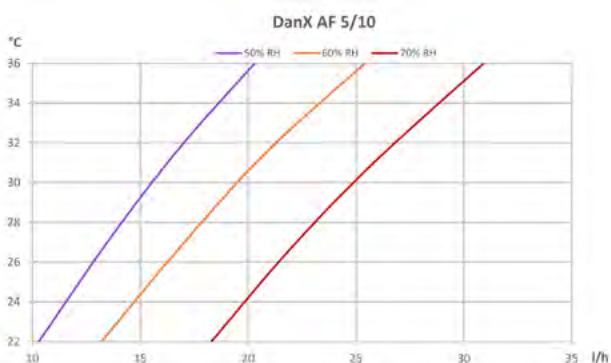
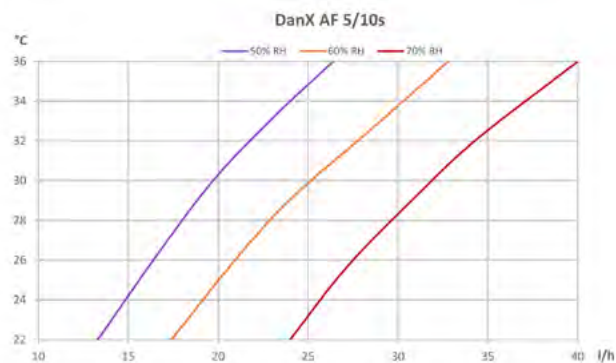
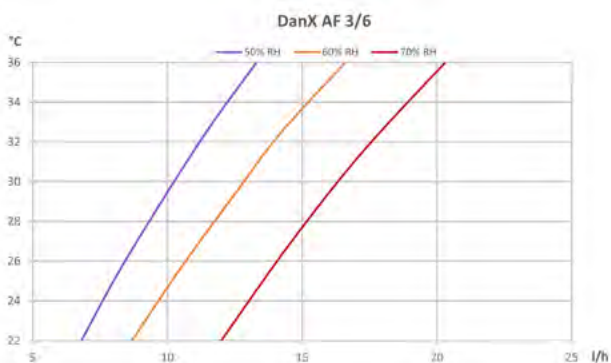

DANX AF

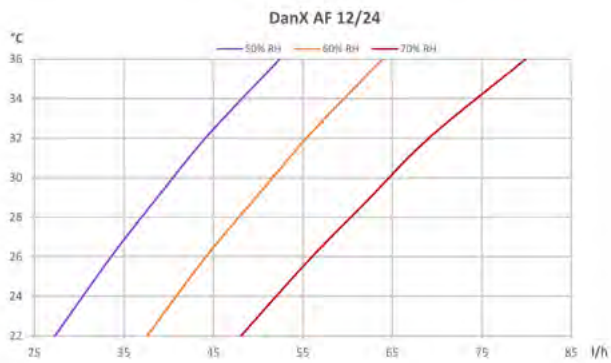
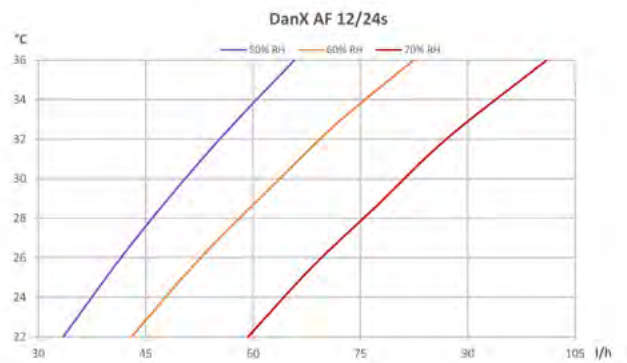
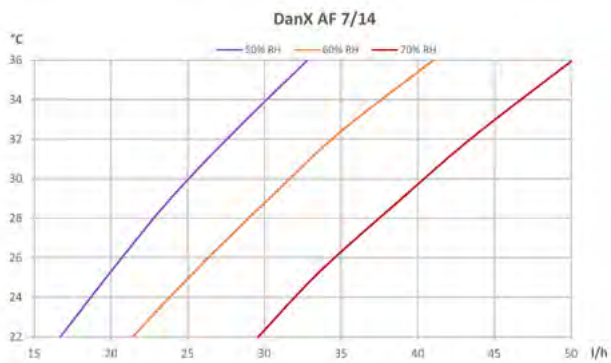



DHP 55

The DHP 33-55-77 are wall-mounted pool dehumidifiers that stand out for their high-performance and high-capacity. They offer great dehumidification capacities and a low energy consumption per liter extracted (SEC). The minimal energy consumption reduces your energy bills while also lowering your CO₂ footprint.

The DHP dehumidifiers have been fitted with an advanced and optimised control system that allows you to adjust the humidity levels to your desired level very accurately. All models operate effortlessly in temperatures as low as 10°C.

The range has been designed for use in both private pools and spa environments of varying sizes.

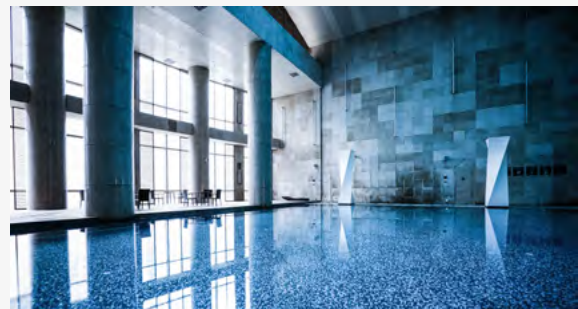

- Great dehumidification capacities
- Low Specific Energy Consumption (SEC)
- Low sound pressure levels
- Wider range of units (incl. size: 77)
- Modbus RS485 RTU communication
- Wireless remote control of setpoints and visibility of room conditions
- Optional remote combi RH/T sensor w/10m cable
- External fan(s) operating on an independent secondary RH setpoint
- USB-A port for data logging and software update
- Continuous, Auto, or Sensing fan operational mode
- Various accessories for specific project customisability

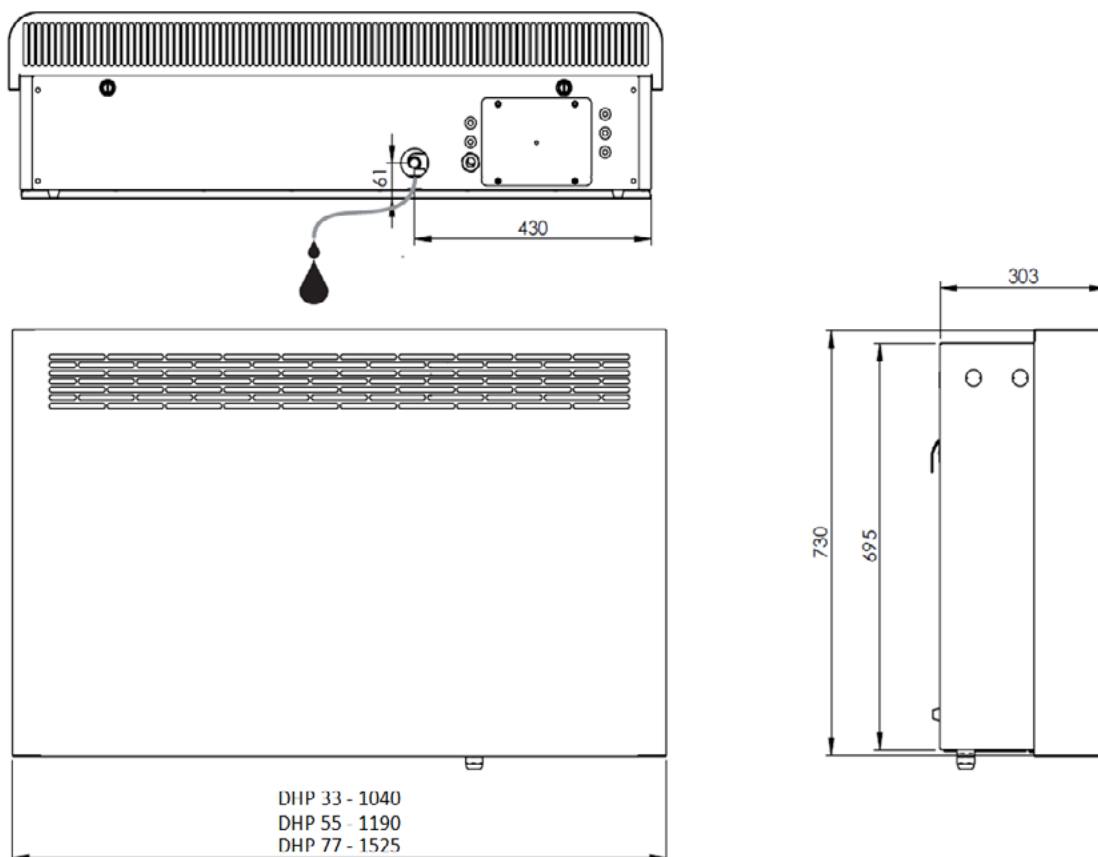

DHP 55

Dimensions (mm)

Specifications	Units	DHP 33	DHP 55	DHP 77
Operating temperature range	°C	10-36	10-36	10-36
Operating humidity range	%	40-100	40-100	40-100
Dehumidification @ 30°C/60% RH	l/24h	38	63	78
SEC @ 30°C/60% RH	kWh/l	0.44	0.49	0.41
Air flow	m ³ /h	400	680	900
Power supply	V/Hz	230/1ph/50	230/1ph/50	230/1ph/50
Power consumption @ 30°C/60% RH	kW	0.70	1.30	1.33
Power consumption max.	kW	0.9	1.5	1.8
Heat recovered @ 30°C/60% RH	kW	2.2	3.4	4.8
Sound pressure level @ 1m	dB(A)	46	47	50
Colour		RAL 9016	RAL 9016	RAL 9016
R407C gas weight/CO ₂ equivalent	kg/t	0.7/1.24	0.9/1.60	1.2/2.13
Product size (w x d x h)	mm	1040 x 317 x 730	1190 x 317 x 730	1525 x 317 x 730
Weight	kg	58.0	66.5	77.0

DHP 33-55-77



Performance data

DHP 33

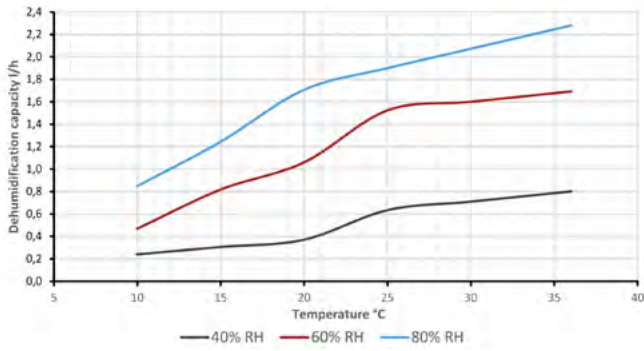

Specific energy consumption (SEC):
0.47 kWh/l at 30°C & 60% RH

DHP 55

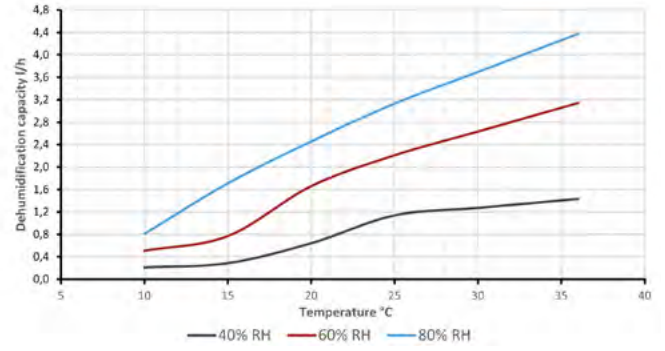

Specific energy consumption (SEC):
0.48 kWh/l at 30°C & 60% RH

DHP 77

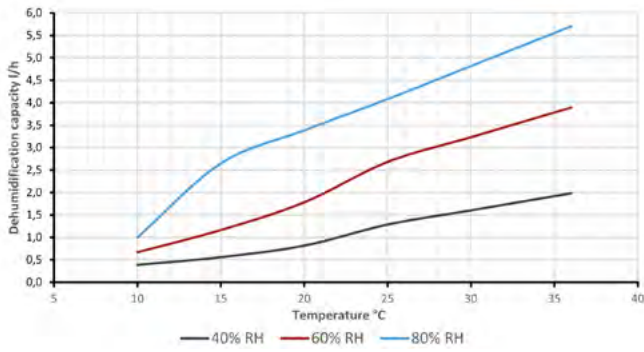

Specific energy consumption (SEC):
0.43 kWh/l at 30°C & 60% RH

Swimming pool dehumidifiers **DHP 33-55-77 TTW**

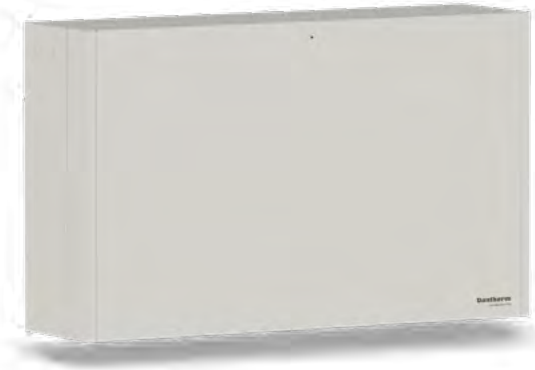

DHP 55 TTW

The DHP 33-55-77 TTW are wall-mounted pool dehumidifiers for through-the-wall installation in adjacent rooms. The dehumidifiers stand out for their high-performance and high-capacity. They offer great dehumidification capacities and a low energy consumption per liter extracted (SEC). The minimal energy consumption reduces your energy bills while also lowering your CO₂ footprint.

The DHP dehumidifiers have been fitted with an advanced and optimised control system that allows you to adjust the humidity levels to your desired level very accurately. All models operate effortlessly in temperatures as low as 10°C.

The range has been designed for use in both private pools and spa environments of varying sizes.



- Great dehumidification capacities
- Low Specific Energy Consumption (SEC)
- Low sound pressure levels
- Wider range of units (incl. size: 77)
- Modbus RS485 RTU communication
- Wireless remote control of setpoints and visibility of room conditions
- Optional remote combi RH/T sensor w/10m cable
- External fan(s) operating on an independent secondary RH setpoint
- USB-A port for data logging and software update
- Continuous, Auto, or Sensing fan operational mode
- Various accessories for specific project customisability
- For through-the-wall installation in adjacent rooms



Swimming pool dehumidifiers

DHP 33-55-77 TTW

Dimensions (mm)

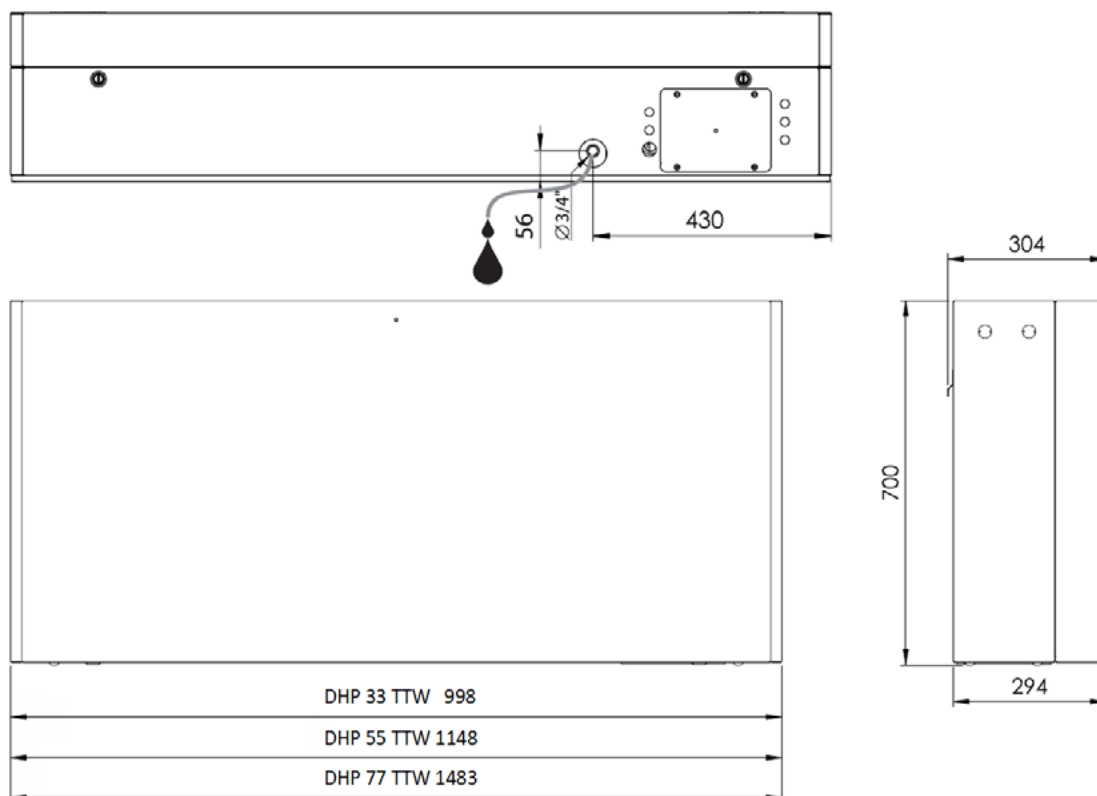

Specifications	Units	DHP 33 TTW	DHP 55 TTW	DHP 77 TTW
Operating temperature range	°C	10-36	10-36	10-36
Operating humidity range	%	40-100	40-100	40-100
Dehumidification @ 30°C/60% RH	l/24h	35	57	81
SEC @ 20°C/60% RH	kWh/l	0.47	0.48	0.43
Air flow	m ³ /h	400	680	900
Power supply	V/Hz	230/1ph/50	230/1ph/50	230/1ph/50
Power consumption @ 20°C/60% RH	kW	0.69	1.04	1.24
Power consumption max.	kW	0.9	1.5	1.8
Heat recovered @ 20°C/60% RH	kW	2.0	3.0	4.2
Sound pressure level @ 1m	dB(A)	43	44	47
Colour		RAL 7035	RAL 7035	RAL 7035
R407C gas weight/CO ₂ equivalent	kg/t	0.7/1.24	0.9/1.60	1.2/2.13
Product size (w x d x h)	mm	998 x 304 x 700	1148 x 304 x 700	1483 x 304 x 700
Weight	kg	57.5	66.0	77.5

Swimming pool dehumidifiers

DHP 33-55-77 TTW



Performance data

DHP 33 TTW

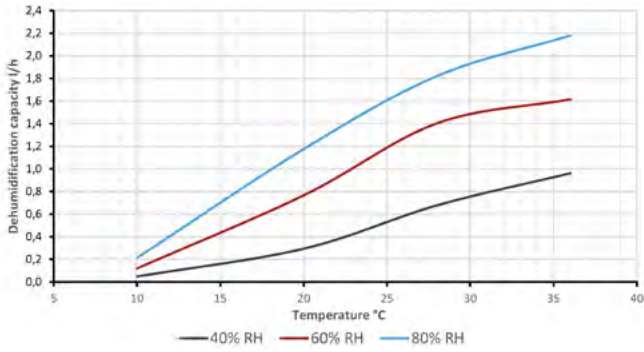

Specific energy consumption (SEC):
0.47 kWh/l at 30°C & 60% RH

DHP 55 TTW

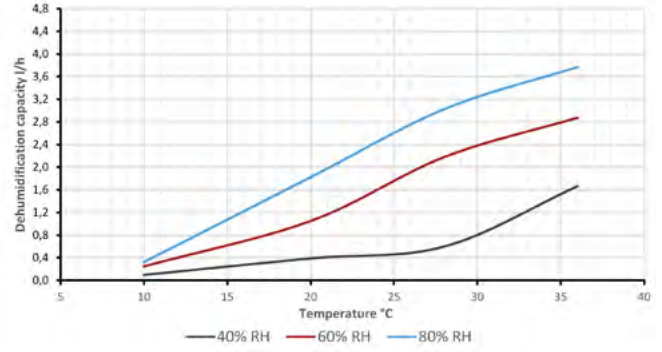

Specific energy consumption (SEC):
0.48 kWh/l at 30°C & 60% RH

DHP 77 TTW

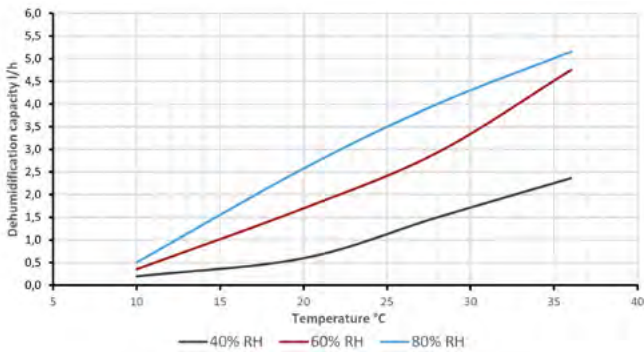

Specific energy consumption (SEC):
0.43 kWh/l at 30°C & 60% RH

**CDF 10**

The CDF 10 dehumidifier is ideal for protecting furnishings and equipment stored at low temperatures. Being fully automatic with electronic control and a built-in, adjustable hygrostat, the unit has a LED that indicates the current status of operation.

Active defrosting is incorporated in the electronic control. The CDF 10 dehumidifier is operational at temperatures down to 3°C, where the electronic control switches off the dehumidifier. Available in white or grey powder coating.

**CDF 10**

with water tank

- Built into a strong and robust powder-coated and hot-galvanised sheet metal cabinet
- Evaporator and condenser coils are epoxy-coated for high corrosion resistance
- The condensate outlet is located at the bottom of the CDF dehumidifier. The outlet stub can be connected to a water hose
- Easy accessible washable air filters from front cover
- Reciprocating compressor
- Axial fan
- Electronic control and user-friendly display panel
- Active, demand-controlled defrosting
- Available in white and grey

Optional accessories

**Room hygromat - 516301****White tank - 351615
Grey tank - 351616**

Specifications	Units	CDF 10
Operating temperature range	°C	3-30
Operating humidity range	% RH	40-100
Dehumidification @ 30°C/60% RH	l/24h	7.5
Air flow	m ³ /h	220
Power supply	V/Hz	230/1ph/50
Max. power consumption	kW	0.3
Sound pressure level @1m	dB(A)	46
R134A gas weight/CO ₂ equivalent	kg/t	0.19/0.27
Water container capacity	l	5.5
Product size (w x d x h)	mm	535 x 240 x 600
Weight	kg	28

Dimensions (mm)

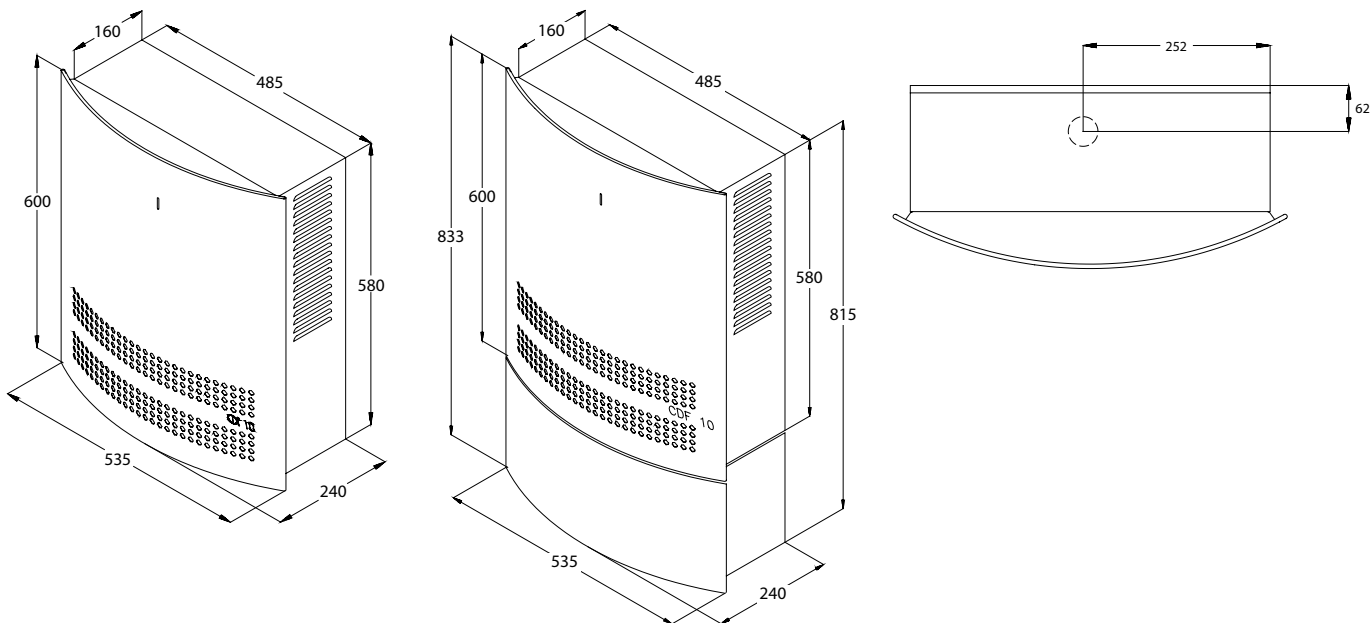

Performance data

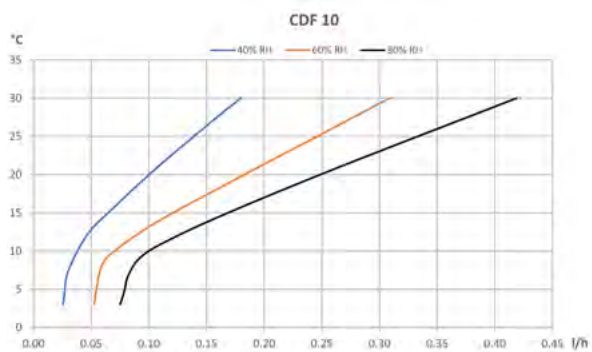

Electronic control

The CDF 10 has a built-in hygrostat and is fully automatic with electronic control. The hygrostat is placed behind the front panel and the required relative humidity level can be adjusted by removing the said front panel. On delivery the CDF 10 is set at approx. 60% RH.

The CDF 10 can be switched on and off by the main power switch on the side of the unit. A green LED on the front panel lights when the compressor is operating.

If the CDF 10 is used with a water container, it switches off automatically when the water tank is full. The LED on the front panel will turn red when the water tank requires emptying.

Defrosting

Active, demand-controlled defrosting is incorporated in the electronic control. A sensor on the evaporator coil ensures that the evaporator is only defrosted when required. The evaporator coil is defrosted by means of hot refrigerant by-passing the condenser and being fed directly into the evaporator.

The CDF 10 is automatically switched off when the temperature is lower than 3°C. It restarts when the room temperature has increased to more than 3°C.

**DH 15**

The DH 15 wall-mounted dehumidifier has a compact design for installation in small areas, making it an ideal solution for stairwells, corridors and changing rooms. Being fully self contained, with tamper proof controls is perfect for public buildings such as schools, museums and galleries.

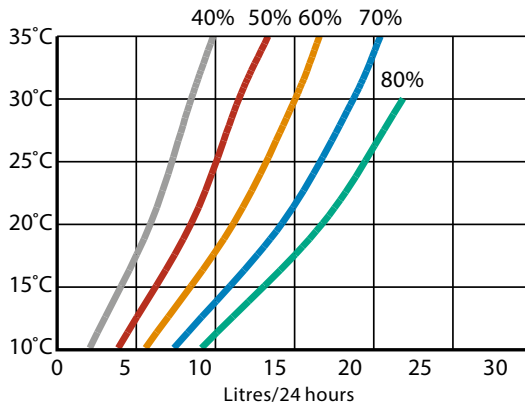
Performance data

- Compact design for installation in small areas
- Self contained with fully automatic operation
- Integral humidistat
- Tamper proof controls
- Epoxy polyester painted zintec steel cabinet
- Hot gas defrost for low temperature operation
- Air filter

Options

- Through-the-wall version

Specifications	Units	DH 15
Operating temperature range	°C	0-35
Operating humidity range	% RH	40-95
Dehumidification capacity*	l/24h	11.0
Specific energy consumption*	kWh/l	0.62
Air flow	m ³ /h	225
Sound pressure level @ 3m	dB(A)	53
R407C gas weight/CO ₂ equivalent	kg/t	0.34/0.6
Power supply	V/Hz	230/1ph/50
Power consumption*	kW	0.30
FLA	A	3.8
Maximum supply fuse	A	10
LRA (compressor start)	A	18
Heat recovered*	kW	0.8
Product size (w x d x h)	mm	825 x 363 x 320
Condensate drain size, ID	mm	10
Weight	kg	33.0

*20°C/60% RH

**AD 110**

The versatile solution for various dehumidification challenges. The AD 110 is compact, lightweight, robust and quiet – really powerful and highly efficient.

Fitted with a bracket for fast and simple wall mounting it's ideally suited for application in water management facilities, car storages, preservation, museums, archives, cellars, spas and domestic use.

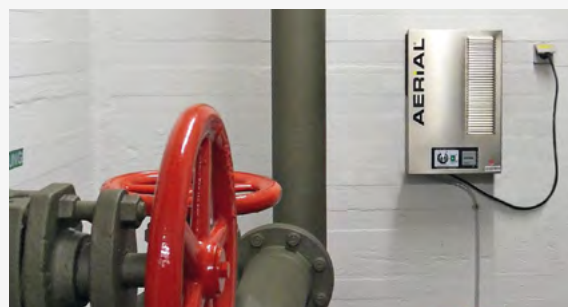

- Case made of stainless steel
- Filtered air is drawn into the unit at the side, and warm dry air is vented through a diffuser at the front
- Compact and space-saving
- Wall-mounted
- Hermetically sealed piston compressor
- Energy-efficient axial fan
- Maintenance-friendly refrigerant circuit with service connector
- Condenser and evaporator made of copper tubes with aluminium fins
- On-demand hot gas defrost system
- Hygrostat for variable humidity control
- Automatic pump-out with overflow protection
- Built-in hour counter

**Included**

- Built-in condensate pump (pump height 3m)
- Replacement filter
- Condensate discharge hose 12 x 2mm
- Hose clip discharge hose 12 x 2/15 x 2mm
- Wall mounting as standard

- Condensation principle (heat-pump technology with energy recovery)
- Suitable for heated rooms up to 140m³ and unheated rooms up to 70m³

Optional accessories

Spare filter
2001189



Condensate discharge hose
12 x 2mm
2002052



Hose clamp discharge hose
12 x 2/15 x 2mm
2003010

**AD 110**

Specifications	Units	AD 110
Capacity (30°C/80% RH)/Power consumption	l/24h/W	15/330
Capacity (20°C/60% RH)/Power consumption	l/24h/W	8.5/236
Capacity (15°C/70% RH)/Power consumption	l/24h/W	8/215
Air flow	m ³ /h	225
Operating temperature range	°C	5-30
Operating humidity range	% RH	35-95
Power supply	V/Hz	230/1ph/50
Sound level	dB(A)	46
Condensate drain	mm	12 x 2
Power cord	m	3 with plug
Refrigerant		R1234yf
Protection class		IP54
Product size (h x w x d)	mm	490 x 330 x 280
Weight	kg	18.5

**DH 60 VPR+****DH 30 VPR+****DH 15 VPR+**

The Trotec DH VPR+ range of high-capacity condensation dehumidifiers is designed to remove excess moisture in commercial or industrial spaces. With dehumidifying capacities ranging from 11 to 50 litres per day, the units effectively control humidity level and prevent the growth of mould and mildew. The DH VPR+ range features an advanced control system that allows you to adjust the humidity levels to your desired level. The DH VPR+ range likewise features hygrostat control for automatic humidity regulation and hot gas automatic defrost system enabling operation in ambient temperatures as low as 5°C.



- High dehumidification performance even at low temperatures
- Corrosion-protected design
- Fully automatic operation
- Automatic hot gas defrosting
- CDC-coated heat exchanger
- Powerful and durable double-flow radial fan
- Unauthorised access protection
- Build-in condensate pump
- Frontpanel available in stainless steel, various special colours, or black carbon fibres
- Factory fitted ionizer for neutralisation of airborne smells and contaminants

Specifications	Units	DH 15 VPR+	DH 30 VPR+	DH 60 VPR+
Operating temperature range	°C	5-40	5-40	5-40
Operating humidity range	% RH	30-90	30-90	30-90
Dehumidification capacity*	l/24h	11	20	38
Specific Energy Consumption*	kWh/l	0.98	0.90	0.63
Air flow rate	m ³ /h	250	745	1065
Sound level @3m	dB(A)	47	52	54
R407C gas weight/CO ₂ equivalent	kg/t	0.34/0.603	0.50/0.887	0.80/1.419
Power supply	V/Hz	230/1ph/50	230/1ph/50	230/1ph/50
Power consumption*	kW	0.45	0.75	1
Heat recovered*	kW	0.7	1.7	2.6
Deice mode	-	Hot gas	Hot gas	Hot gas
Product size (w x d x h)	mm	829 x 395 x 339	787 x 280 x 690	1255 x 280 x 690
Weight	kg	37	57	90
*20°C/60% RH				

Performance data

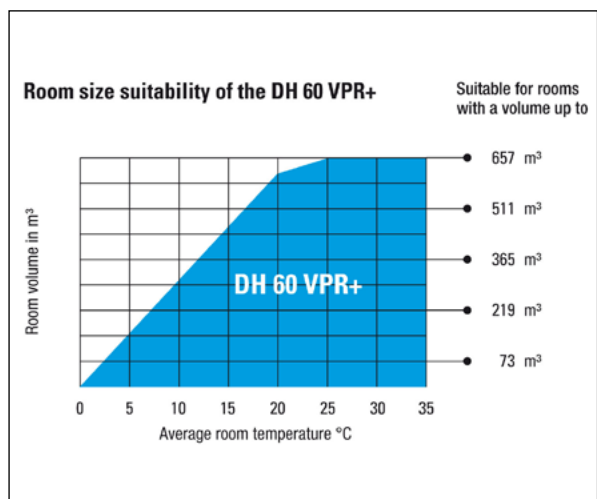
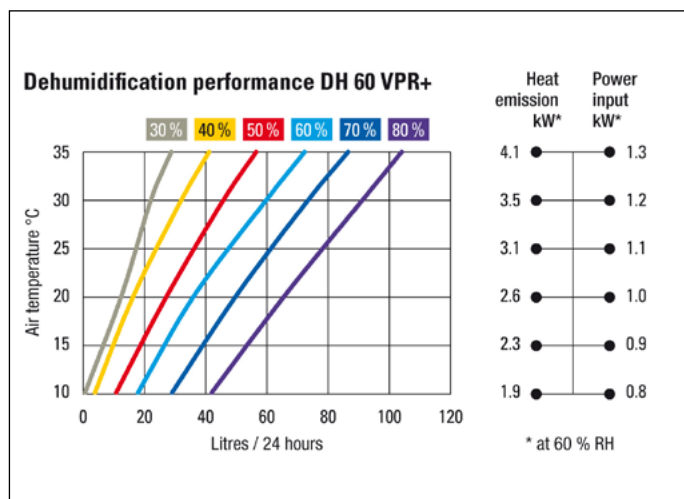
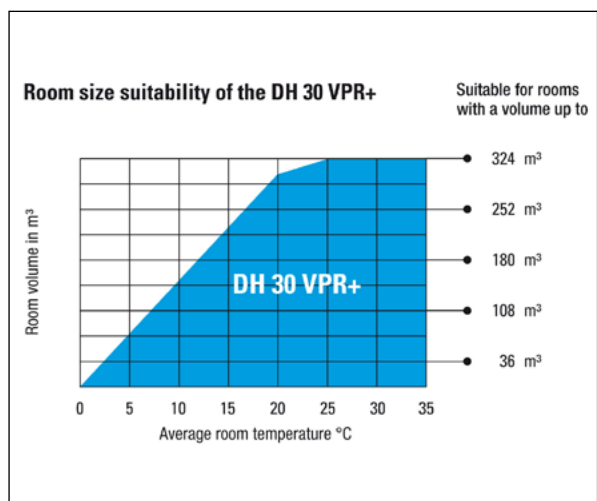
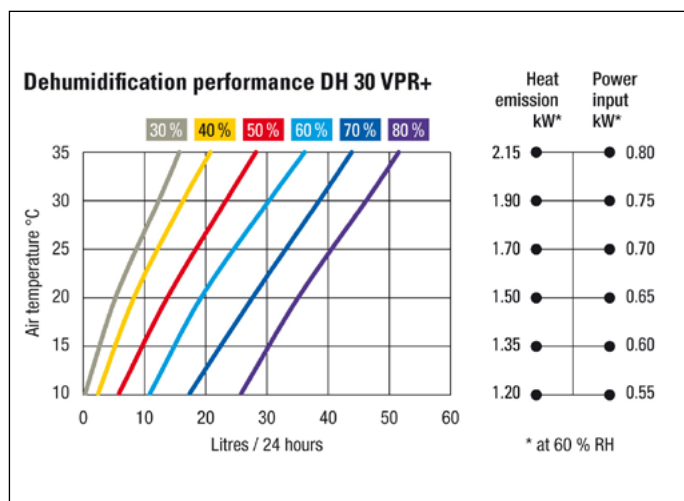
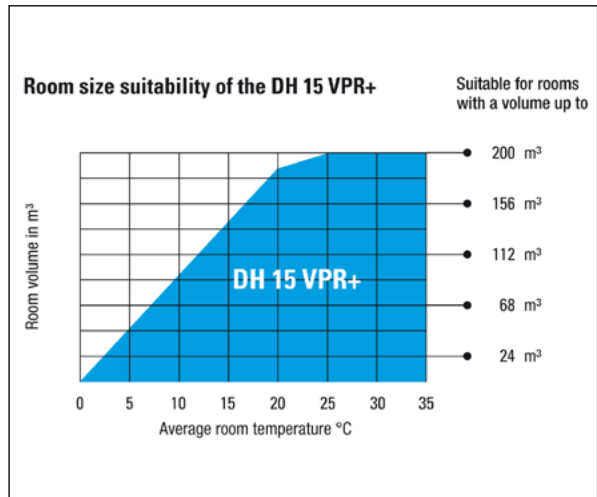
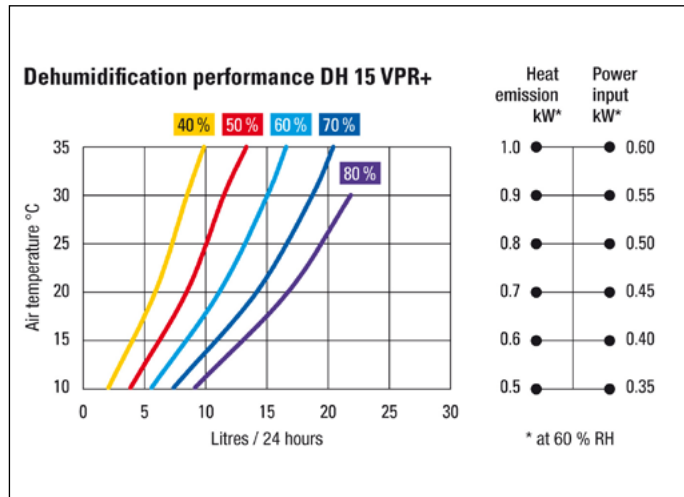

**CDF 40**

The energy-efficient and quiet CDF range of powerful dehumidifiers is ideal for preserving and protecting your valuables from humidity damage. They are suitable for humidity control in garages, warehouses, museums, churches, archives and waterworks.

- Modern design
- Low sound level
- Low energy consumption
- Integrated control of humidity and temperature
- BMS communication (Modbus RTU)
- Built into a strong and robust powder-coated and hot-galvanised sheet metal cabinet
- Evaporator and condenser coils epoxy-coated to maximise corrosion resistance
- Three operational modes
- Visualized operational conditions for easy troubleshooting

Controls

- Built in electronic hygrostat and thermostat
- Integrated ON/OFF control of humidity and temperature (electric or water heating coils as accessories)
- 230 V for control valve, exhaust fan and or pump/boiler
- RS485 for Modbus communication

Optional accessories
Wireless remote control DRC1- 112450

Floor mounting kit - 094332

Water heating coils - 094333, 094334, 094335

Control valve for water heating coil - 094340

Electric heating coils - 094336, 094337, 094338

Exhaust fans - 094339, 094341

Specifications	Units	CDF 40	CDF 50	CDF 70
Operating temperature range	°C	3-32	3-32	3-32
Operating humidity range	% RH	40-100	40-100	40-100
Dehumidification capacity*	l/24h	25.4	39.9	42.7
Specific energy consumption*	kWh/l	0.57	0.61	0.45
Air flow	m ³ /h	400	680	900
Sound pressure level @1m	dB(A)	46	47	50
R407C gas weight/CO ₂ equivalent	kg/t	0.7/1.24	0.9/1.60	1.2/2.13
Power supply	V/Hz	230/1ph/50	230/1ph/50	230/1ph/50
Power consumption*	kW	0.60	0.99	0.80
Power consumption w/elec. heater*	kW	2.60	4.50	5.80
Heat recovered*	kW	1.48	2.17	3.47
Product size (w x d x h)	mm	1010 x 326 x 770	1160 x 326 x 770	1495 x 326 x 770
Weight	kg	56.5	65.0	75.5

*20°C/60% RH

Dimensions (mm)

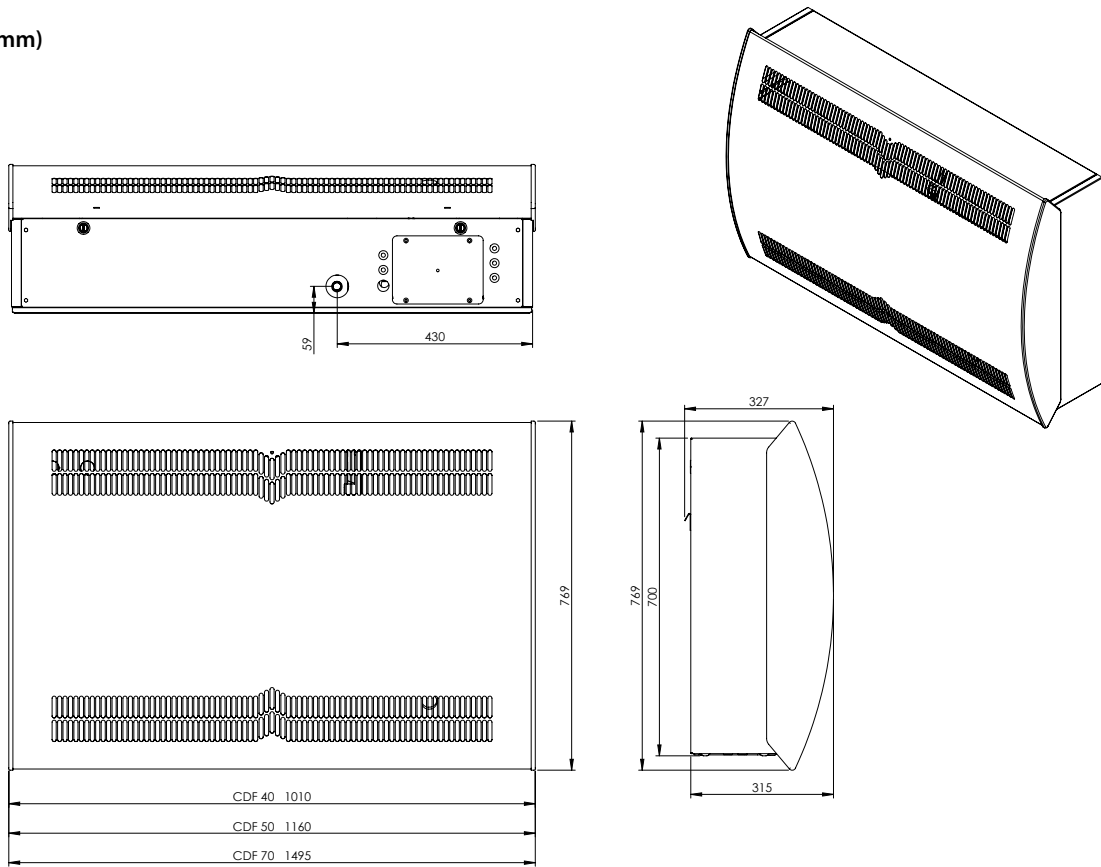

Performance data

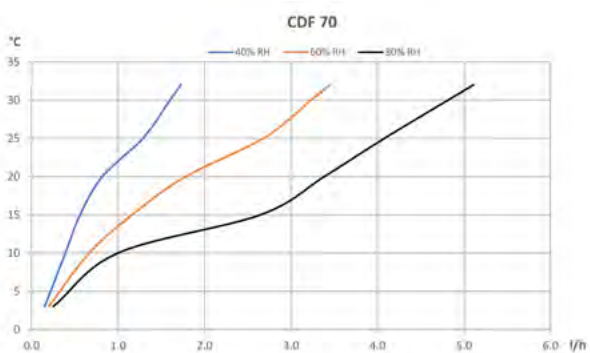
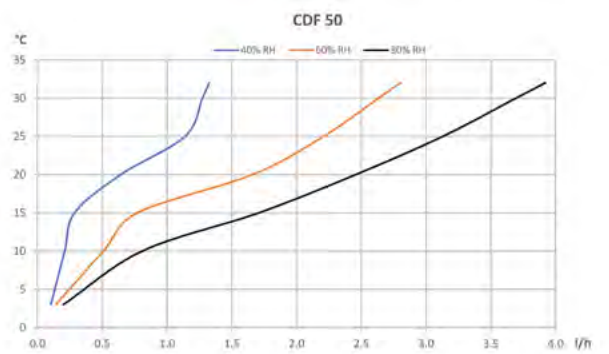
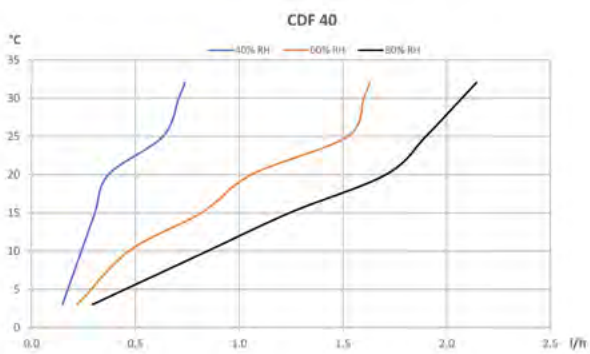

AERIAL WT 230-240-250-280



WT 230, WT 240, WT 250, WT 280

Drying laundry with one or several regular clothes driers (tumble-dryers) is very energy-intensive. To save energy, laundry can be dried outside in the fresh air during the summer. But what to do in bad weather or during the winter? A laundry room equipped with a Dantherm clothes dryer constitutes a reliable, environmentally friendly alternative, to be used as air dehumidifiers keeping rooms permanently dry and avoiding mould and damage to the property as well as health issues due to excessive humidity.

The unique air filter system is particularly easy to remove and can be cleaned with water or manually.



- Case made of galvanised steel; Hood made of easy to clean plastic. Service-friendly housing construction
- Space-saving wall mounting
- Hermetically sealed rotary compressor
- Energy-efficient EC-radial fan
- Maintenance-friendly refrigerant circuit with service connector
- Condenser and evaporator made of copper tubes with aluminium fins
- On-demand hot gas defrost system for optimum operation in a cool places



- Condensation principle (heat-pump technology with energy recovery)
- WT 230
Laundry drying: approx. 7.5kg dry laundry
Room drying: closed rooms up to 450m³
- WT 240
Laundry drying: approx. 10kg dry laundry
Room drying: closed rooms up to 500m³
- WT 250
Laundry drying: approx. 15kg dry laundry
Room drying: closed rooms up to 600m³
- WT 280
Laundry drying: approx. 20kg dry laundry
Room drying: closed rooms up to 900m³

Optional accessories



Spare filter (Gaze)
2001216



Pump kit PK-Uni
2002326



Specifications	Units	WT 230	WT 240	WT 250	WT 280
Capacity (30°C/80% RH)/Power consumption	l/24h/W	35.5/570	36.5/570	57.1/887	79.2/1390
Capacity (27°C/60% RH)/Power consumption	l/24h/W	21.1/487	21.6/500	24.1/806	46.6/1080
Capacity (20°C/60% RH)/Power consumption	l/24h/W	14.6/420	16.8/440	23.0/677	32.2/990
Capacity (10°C/70% RH)/Power consumption	l/24h/W	6.1/368	7.2/360	13.4/564	20.3/800
Air flow	m ³ /h	750	830	870	920
Energy consumption per kg laundry	kWh/kg	0.29	0.25	0.27	0.30
Drying time	h:mm	4:55	5:35	5:23	5:13
Operating temperature range	°C	3-32	3-32	3-32	3-32
Operating humidity range	% RH	35-95	35-95	35-95	35-95
Power supply	V/Hz	230/1ph/50	230/1ph/50	230/1ph/50	230/1ph/50
Sound level	dB(A)	61	61	60	66
Condensate drain	mm	15 x 2	15 x 2	15 x 2	15 x 2
Power cord	m	4.5 with plug	4.5 with plug	4.5 with plug	4.5 with plug
Refrigerant	kg/t	R407c	R407c	R407c	R407c
Protection class		IP12	IP12	IP12	IP12
Product size (h x w x d)	mm	809 x 640 x 345	809 x 640 x 345	809 x 640 x 345	809 x 640 x 345
Weight	kg	40	40	42	43

DHC 33-55-77



DHC 55

The Dantherm DHC 33-55-77 are wall-mounted dehumidifiers that stand out for their high-performance and high-capacity. The DHC wide range of units offers great dehumidification capacities and low energy consumption per liter extracted.

The DHC range's advanced control system allows you to adjust the humidity levels to your desired level. DHC features enable operation in temperatures as low as 3°C. Designed for commercial and industrial spaces.



- Great dehumidification capacities
- Low Specific Energy Consumption (SEC)
- Low sound pressure levels
- Wider range of units (incl. size: **77**)
- Modbus RS485 RTU communication
- Wireless remote control of setpoints and visibility of room conditions
- Optional remote combi RH/T sensor w/10m cable
- External fan(s) operating on an independent secondary RH setpoint
- USB-A port for data logging and software update
- Continuous, Auto, or Sensing fan operational mode
- Various accessories for specific project customizability



DHC 55

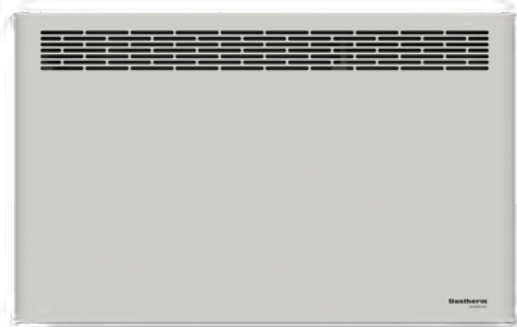

DHC 33-55-77



Dimensions (mm)

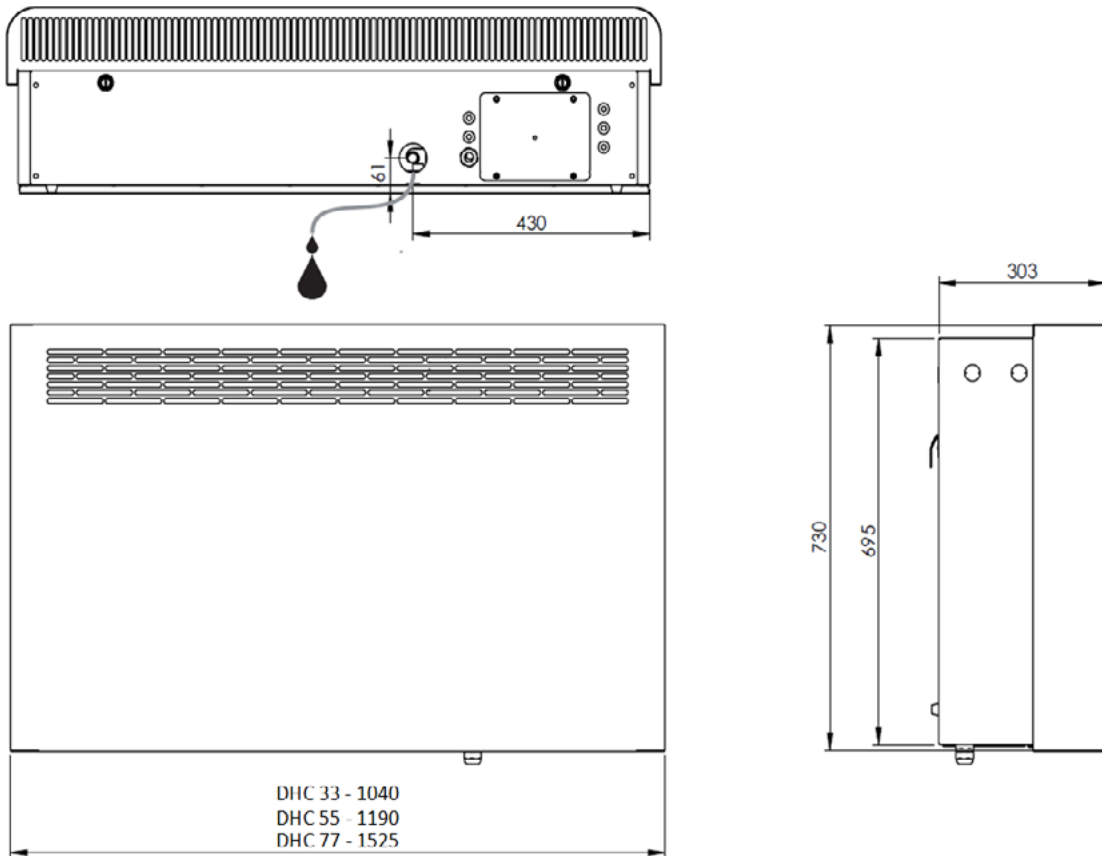

Specifications	Units	DHC 33	DHC 55	DHC 77
Operating temperature range	°C	3-32	3-32	3-32
Operating humidity range	%	40-100	40-100	40-100
Dehumidification @ 20°C/60% RH	l/24h	25	40	43
SEC @ 20°C/60% RH	kWh/l	0.57	0.61	0.45
Air flow	m ³ /h	400	680	900
Power supply	V/Hz	230/1ph/50	230/1ph/50	230/1ph/50
Power consumption @ 20°C/60% RH	kW	0.60	1.01	0.80
Power consumption max.	kW	0.9	1.5	1.8
Heat recovered @ 20°C/60% RH	kW	1.5	2.2	3.5
Sound pressure level @ 1m	dB(A)	46	47	50
R407C gas weight/CO ₂ equivalent	kg/t	0.7/1.24	0.9/1.60	1.2/2.13
Product size (w x d x h)	mm	1040 x 317 x 730	1190 x 317 x 730	1525 x 317 x 730
Weight	kg	58.0	66.5	77.0

DHC 33-55-77



Performance data

DHC 33

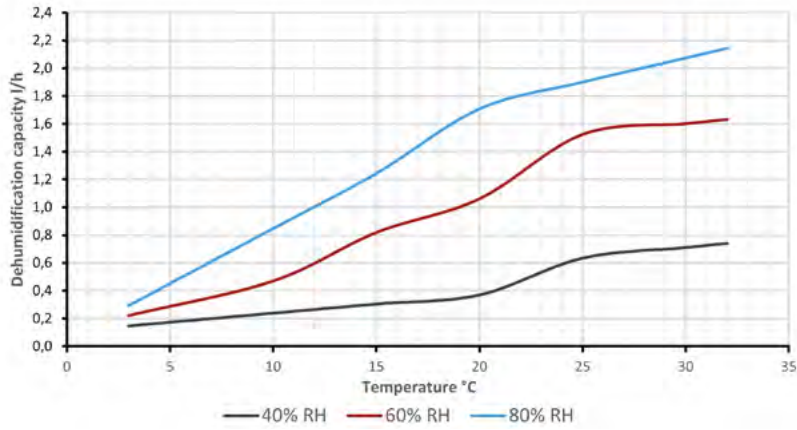

Specific energy consumption (SEC):
0.57 kWh/l at 20°C & 60% RH

DHC 55

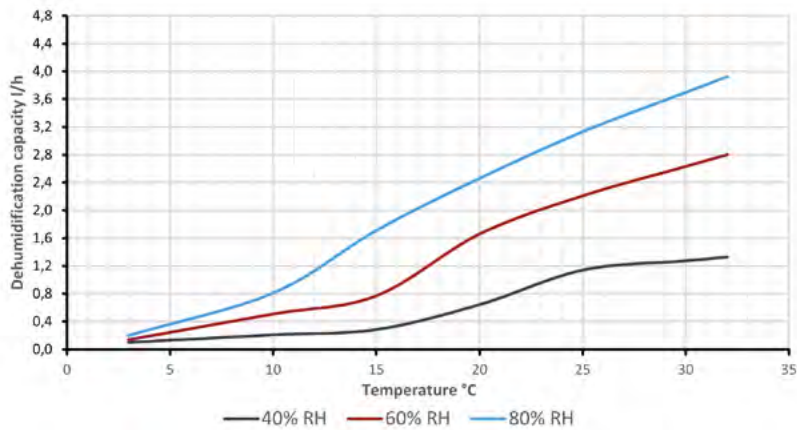

Specific energy consumption (SEC):
0.61 kWh/l at 20°C & 60% RH

DHC 77

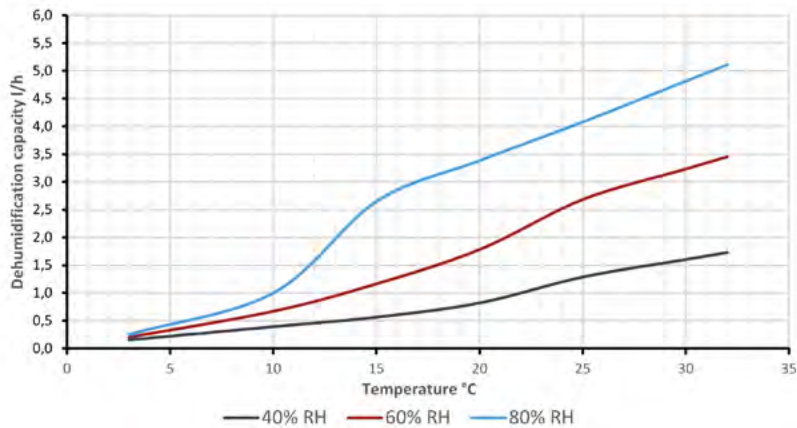

Specific energy consumption (SEC):
0.45 kWh/l at 20°C & 60% RH

DH 160-310



DH 160-310

The industrial dryers DH 160 and DH 310 that can also be supplied in a stainless steel housing are equally characterised by high dehumidification capacity, reliable continuous operation properties and practice-oriented equipment options.

Designed for the operation whilst positioned on the floor, the devices – given on-site preparation – can also easily be used when mounted to the wall or ceiling. Also they can be connects to existing ducted air systems.

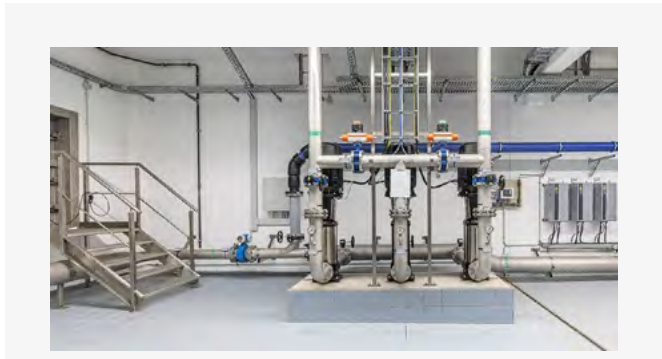

- High dehumidification performance even at low temperatures
- Robust and corrosion-protected design
- Fully automatic operation
- Automatic hot gas defrost system
- Optional defrosting down to -0.5°C
- Self-regulating stepless EC double-flow radial fan
- Reduces energy needs for separate heating
- DIN socket for external equipment
- Integrated condensate pump
- Stainless steel housing option
- Energy consumption meter, MID-compliant

Optional accessories



HG 120 S Hygrostat
6.100.002.040

Performance data

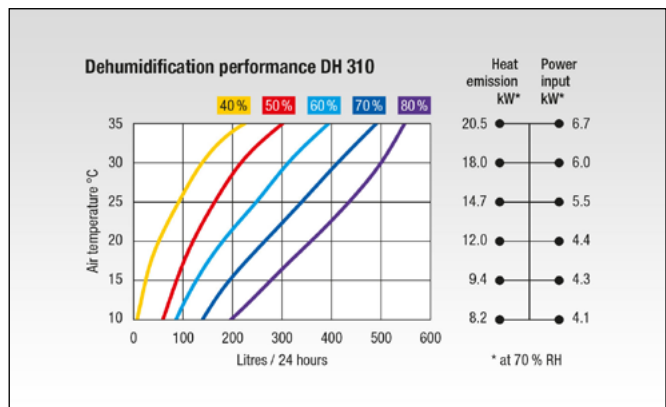
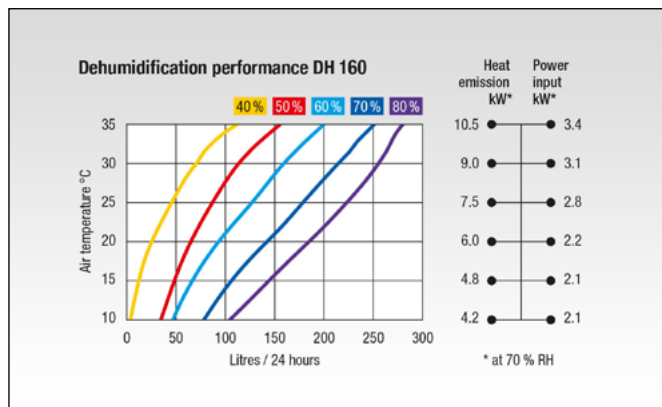

DH 160-310



Specifications	Units	DH 160	DH 310
Dehumidification performance @ 30°C/80% RH	l/24h	85	500
Air flow rate	m ³ /h	2,200	4,600
Operating temperature range	°C	1.5-42	1.5-42
Operating range humidity max.	% RH	95	95
Power supply	V/Hz	400/3ph/50	400/3ph/50
Nominal current consumption	A	9.5	11
Power input	kW	3.5	6.9
Starting current	A	50	75
Refrigerant	Type	R407C	R407C
Quantity of refrigerant	g	2,250	3,200
Fan		Radial	Radial
Compressor		Scroll compressor	Scroll compressor
Defrosting		Hot gas	Hot gas
Sound level @3m	dB(A)	59	60
Product size (l x w x h)	mm	560 x 700 x 1355	690 x 1080 x 1715
Weight	kg	150	260
Condensate discharge connection	Ømm	16	16

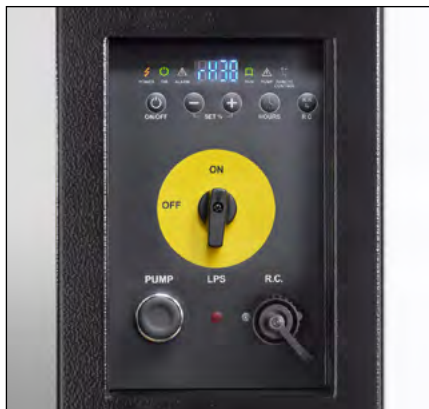

CALOREX DH 150-300-600

DH 150



DH 300



DH 600



- Self contained with fully automatic operation
- Integral humidistat
- Polyester coated evaporator and condenser
- Platisol coated galvanised steel cabinet
- Hot gas defrost for low temperature operation
- Reverse cycle defrost for very low temperature operation (DH 150)
- Constant flow fan – automatically adjusts to ducting (DH 150 and 300)

The DH 150-300-600 high capacity floor-standing dehumidifiers are self contained with fully automatic operation. With an integral humidistat and options for heating, you can be confident in your space being controlled to your needs. A 'constant flow' fan is standard for the DH 150-300, which self-regulates independent on the external pressure loss from ducts, grills, etc. This makes it ideal for warehousing and storage, sub stations and data centres.

Options DH 150

- Return air filter
- Top discharge box
- Stainless steel casing

Options DH 300

- Return air filter

Options DH 600

- Return air filter
- Top discharge box

CALOREX DH 150-300-600



Performance data DH 150

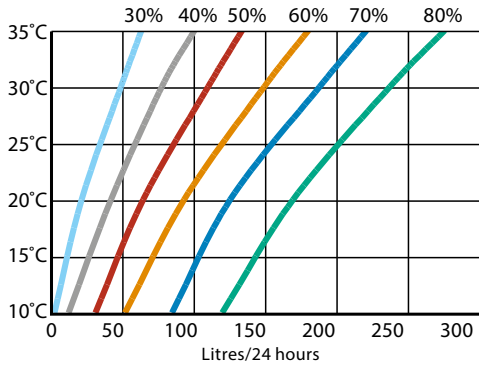

Performance data DH 300

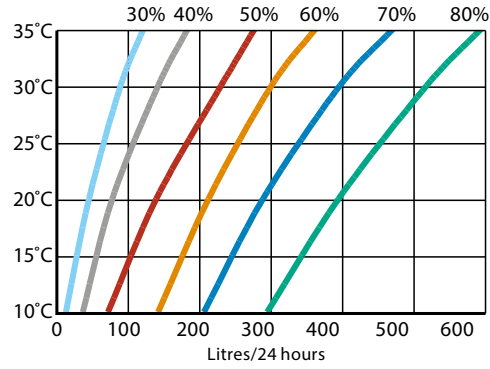

Performance data DH 600

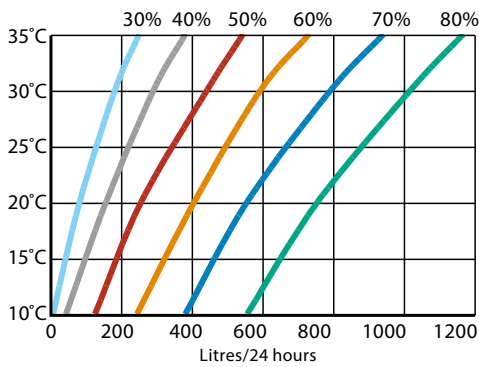

CALOREX DH 150-300-600

Specifications	Units	DH 150AX	DH 150BX
Operating temperature range	°C	0-35	0-35
Operating humidity range	% RH		
Dehumidification @ 30°C/60% RH	l/24h	150	150
Heat recovered to air @ 30°C/60% RH	kW	7.4	7.4
Air flow	m ³ /h	2,500	2,500
Available static pressure	Pa	0-200	0-200
Sound pressure level @ 3m	dB(A)	58	58
Power supply	V/Hz	230/1ph/50	400/3ph/50
Nominal power consumption	kW	2.3	2.3
FLA (electrical)	A	21	11.6
Maximum supply fuse	A	30	16
LRA (compressor start)	A	86	36
Heater type	Optional	Top box electric	Top box electric
Heater output	kW	9.0	9.0
FLA (heater)	A	36	12
Maximum fuse size	A	50	16
R407C gas weight/CO ₂ equivalent	kg/t	2.50/4.44	2.75/4.88
Product size (w x d x h)	mm	660 x 660 x 1313	660 x 660 x 1313
Weight	kg	130	130
Condensate drain size	inch	¾ BSPM	¾ BSPM

Specifications	Units	DH 300BY	DH 600BY
Operating temperature range	°C	-15-35	-15-35
Dehumidification @ 30°C/60% RH	l/24h	300	600
Heat recovered to air @ 30°C/60% RH	kW	14.7	29.7
Air flow	m ³ /h	5,000	9,000
Available external static pressure	Pa	0-140	0-160
Sound pressure level @ 3m	dB(A)	66	63
Power supply	V/Hz	400/3ph/50	400/3ph/50
Nominal power consumption	kW	7.3	10.0
FLA	A	19	27
Maximum supply fuse	A	24	35
LRA (compressor start)	A	66	135
R407C gas weight/CO ₂ equivalent	kg/t	10.0/17.74	14.0/24.84
Product size (w x d x h)	mm	980 x 826 x 1475	1730 x 1250 x 1600
Weight	kg	220	497
Condensate drain size, ID (flexible plastic hose)	inch	1½ BSPM	1½ BSPM



DH 25-65-95-105-115 S-145 SH

DH-S condenser dryers combine global procurement management and local production refinement at the production location Germany. That is how they provide two decisive advantages in one device:

The attractive price-performance-ratio of an international standard solution for many traditional dry keeping tasks and a modular refinement of electrical systems and aquiferous components meeting European standards – all manually finished and quality-controlled in Germany.

Therefore, with the DH-S series offers a reliable standard solutions for cost-effective dehumidification whenever a protection against corrosion and condensation in production and storage areas for industry, logistics or supply is requested.



- Reliable dryer with a high dehumidification capacity
- Very cost-effective for drying applications in production facilities and warehouses
- Powerful integrated condensate pump for drainage across floors (up to 4 m)
- Reduces energy needs for separate heating
- Automatic hot gas defrost system (DH 105 S, DH 115 S, DH 145 SH)
- Pressure gauge indicator for early fault detection



Specifications	Units	DH 25 S	DH 65 S	DH 95 S	DH 105 S	DH 115 S	DH 145 SH
Dehumidification performance @ 30°C/80% RH	l/24h	40	80	130	175	245	485
Dehumidification performance @ 20°C/60% RH	l/24h	16	30	35	70	97	193
Suitable for keeping dry rooms up to	m ³	600	1,200	1,600	2,500	3,200	4,500
Air flow rate	% RH	450	1,100	1,100	1,700	2,150	4,300
Hygrostat		Electronic	Electronic	Electronic	Electronic	Electronic	Analog
Operating temperature range	°C	1-35	1-35	5-35	5-32	5-35	5-32
Power supply	V/Hz	230/1ph/50	230/1ph/50	380/1ph/50	380/1ph/50	380/1ph/50	400/3ph/50
Power input	kW	0.7	1.48	2.77	3.0	4.9	9.8
Nominal capacity		0.57	1.05	1.7	3.3	4.2	9.4
Nominal current	A	3.1	7.6	13.2	5.2	8.5	16.6
Fuse	A	16	16	16	16	25	32
Refrigerant	Type	R290	R1234yf	R410A	R410A	R410A	R407C
Quantity of refrigerant	g	152	750	1,350	1,400	1,730	3,200
Evaporator		Tube evaporator	Tube evaporator	Fin evaporator	Fin evaporator	Fin evaporator	Fin evaporator
Defrosting		Hot gas	Hot gas	Hot gas	Hot gas	Hot gas	Hot gas
Sound level @3m	dB(A)	51	56	53	56	56	56
Product size (l x w x h)	mm	580 x 350 x 455	662 x 510 x 525	465 x 600 x 910	470 x 615 x 1635	470 x 755 x 1635	460 x 1195 x 1730
Weight	kg	32	53	65	124	150	235

DH 20



DH 20

The compact DH 20 condensation dehumidifier is designed to manage excess moisture in small commercial areas. It can remove up to 12.6 litres of moisture per day at 20°C and 60% relative humidity, effectively controlling humidity levels to prevent mould and mildew growth.

The wall-mounted unit has an easy-to-use control system that lets you set your desired humidity level. It features a durable aluminium housing with cataphoresis-painted coils for corrosion resistance as well as an electronic humidistat for precise control.



- Aluminium housing and cataphoresis painted coils for corrosion resistance
- Electronic humidistat for improved humidity control
- Designed for wall mounting
- Direct water drainage
- User-friendly dashboard
- Modern design
- Easy to install and use

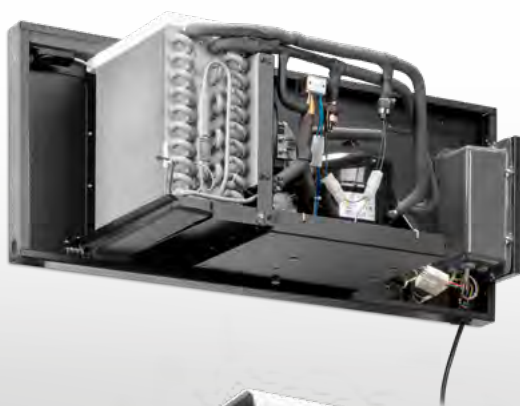

DH 20

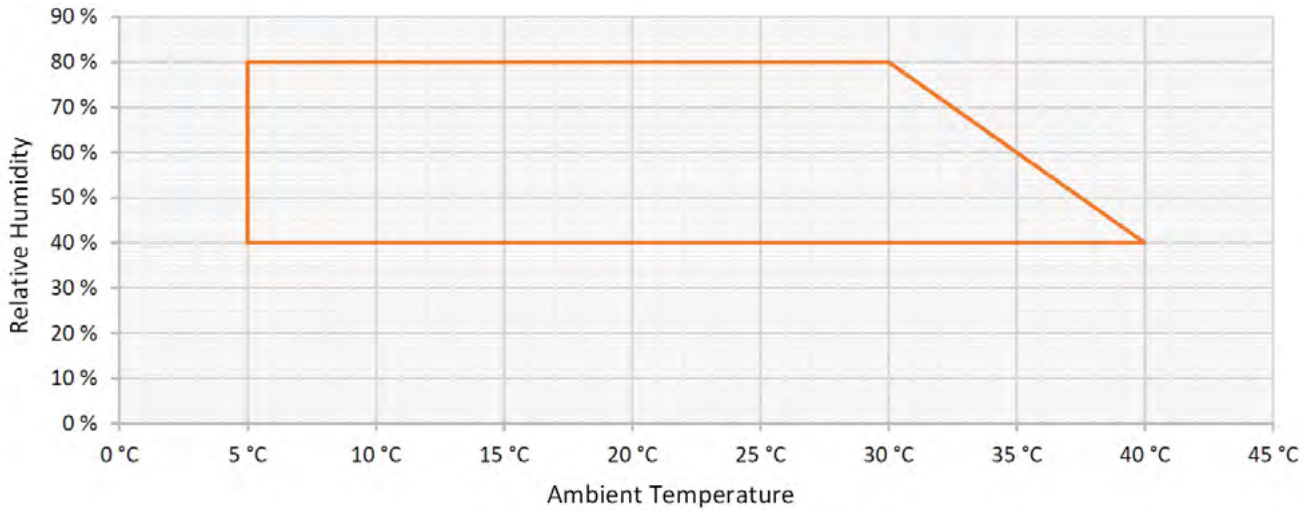

Operational range

Specifications	Units	DH 20
Operating temperature range	°C	5-40
Operating humidity range	%	40-80
Air flow	m ³ /h	375
Sound pressure level @ 1 m	dB(A)	48
Dehumidification capacity*	l/24h	18.4
Dehumidification capacity**	l/24h	12.6
Specific Energy Consumption*	kWh/l	0.66
Specific Energy Consumption**	kWh/l	0.82
R290C gas weight/CO ₂ equivalent	kg/t	0.15/0.0005
Power supply	V/Hz	230/1ph/50
Power consumption, max	kW	0.51
Current, max.	A	2.3
Product size (W x D x H)	mm	900 x 350 x 365
Weight	kg/t	33

*30°C/60% RH, **20°C/60% RH

DH 35-65



DH 35-65

The DH 35/65 condensation dehumidifiers are designed to manage excess moisture in swimming pool areas as well as commercial and industrial spaces. The wall-mounted units can remove up to 29.3 (DH 35) and 45.8 (DH 65) litres of moisture per day, effectively controlling humidity levels to prevent mould and mildew growth.

The dehumidifiers have been fitted with an easy-to-use control system that lets you set your desired humidity level. They feature a durable aluminium housing with cataphoresis-painted coils for corrosion resistance as well as an electronic humidistat for precise control. The factory-installed heating coil ensures a constant temperature within the room.



- Aluminium housing and cataphoresis painted coils for corrosion resistance
- Electronic humidistat for improved humidity control
- Factory fitted electrical and LPHW heating coils specified for 55°C water temperature
- Designed for wall mounting
- Direct water drainage
- User friendly dashboard
- Modern design
- Easy to install and use



DH 35



DH 65

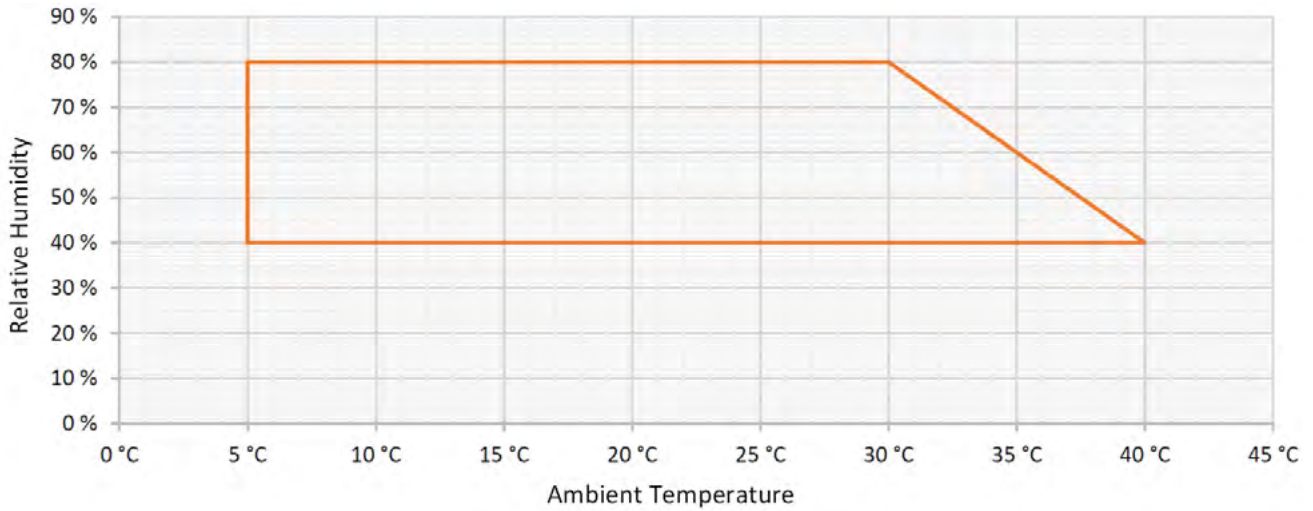

Operational range

Specifications	Units	DH 35	DH 65
Operating temperature range	°C	5-40	5-40
Operating humidity range	%	40-80	40-80
Air flow	m ³ /h	500	800
Sound pressure level @ 1 m	dB(A)	48	48
Dehumidification capacity*	l/24h	29.3	45.8
Dehumidification capacity**	l/24h	20.2	31.9
Specific Energy Consumption*	kWh/l	0.72	0.57
Specific Energy Consumption**	kWh/l	0.83	0.65
R454C gas weight/CO ₂ equivalent	kg/t	0.50/0.074	0.85/0.126
Power supply	V/Hz	230/1ph/50	230/1ph/50
Power consumption, max	kW	1.0	1.2
Current, max.	A	4.3	5.3
Product size (W x D x H)	mm	885 x 265 x 720	1306 x 265 x 720
Weight	kg/t	50	76

*30°C/60% RH, **20°C/60% RH

DH 120



DH 120

The DH 120 is a powerful condensation dehumidifier designed to manage excess moisture in swimming pool areas as well as commercial and industrial spaces. The floor-standing dehumidifier can remove up to 164.3 litres of moisture per day, effectively controlling humidity levels to prevent mould and mildew growth.

The dehumidifier has been fitted with an easy-to-use control system that lets you set your desired humidity level. It features a durable aluminium housing with cataphoresis-painted coils for corrosion resistance, an electronic humidistat for precise control, and the two fan speed modes Comfort and Boost.

The factory-installed low-pressure hot water heating coil is designed for water temperatures of 55°C.



- Aluminium housing and cataphoresis painted coils for corrosion resistance
- Electronic humidistat for improved humidity control
- Two fan speed modes – Comfort and Boost
- Factory-fitted LPHW heating coil specified for 55°C water temperature
- Designed as a floor-standing unit
- Direct water drainage
- User friendly dashboard
- Modern design
- Easy to install and use

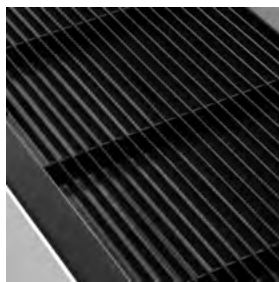

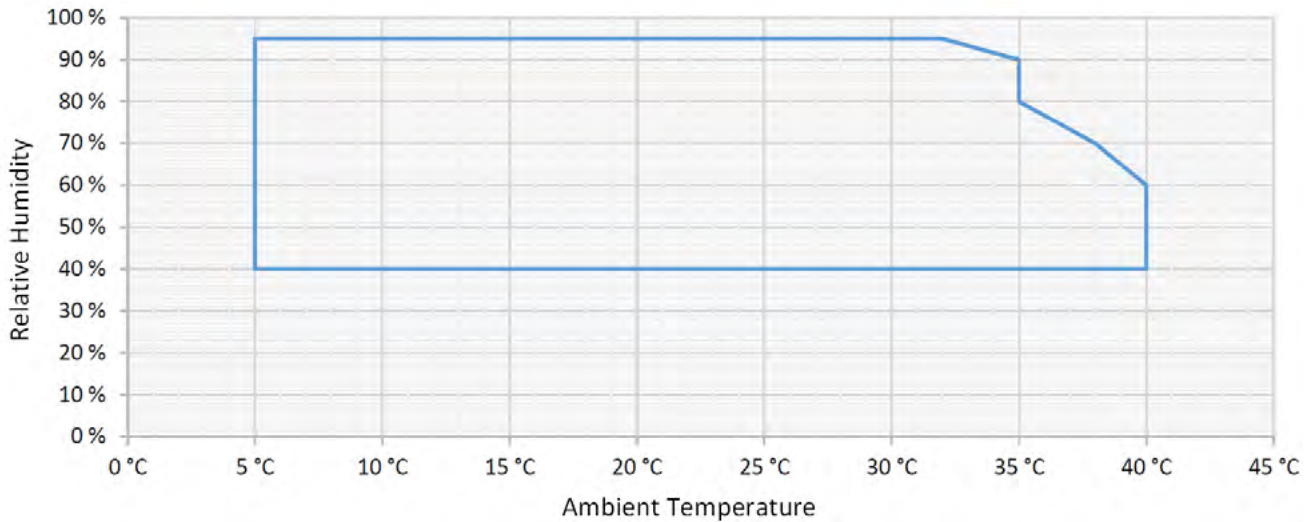
Operational range

Specifications	Units	DH 120
Operating temperature range	°C	5-40
Operating humidity range	%	40-95
Air flow (comfort / boost)	m ³ /h	800 / 1200
Sound pressure level @ 1 m	dB(A)	51 / 56
Dehumidification capacity*	l/24h	92.5
Dehumidification capacity**	l/24h	66.0
Dehumidification capacity***	l/24h	164.3
Specific Energy Consumption*	kWh/l	0.51
Specific Energy Consumption**	kWh/l	0.56
R454C gas weight/CO ₂ equivalent	kg/t	1.6/0.237
Power supply (incl. E plug and 3 m cable)	V/Hz	230/1ph/50
Power consumption, max	kW	2.6
Current, max.	A	11.7
Product size (W x D x H)	mm	1410 × 365 × 860
Weight	kg/t	130

*30°C/60% RH, **20°C/60% RH ***35°C/80% RH

DH 20-35-65-120



Dehumidification capacity

DH 20

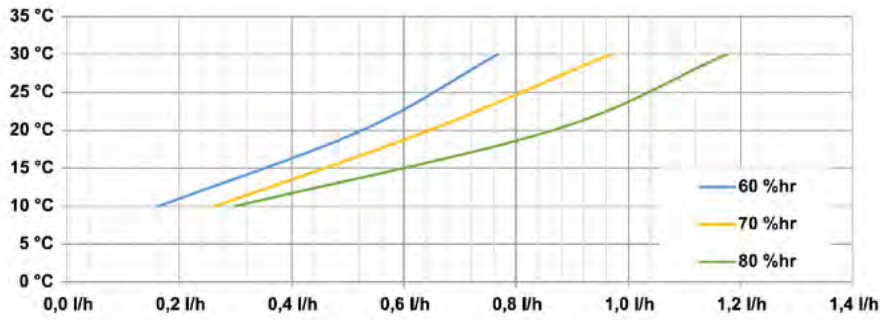

DH 35

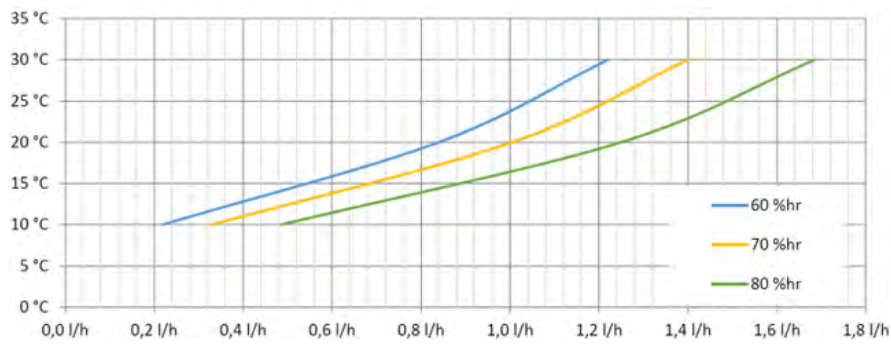

DH 65

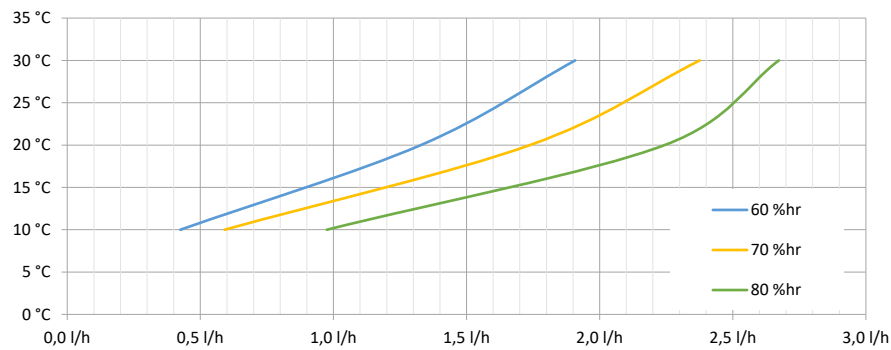

DH 120

"Comfort" mode

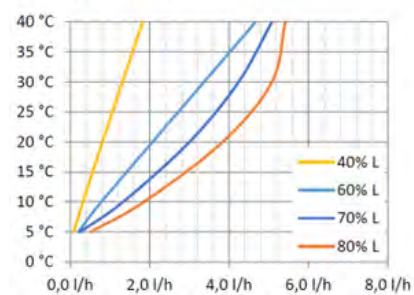

"Boost" mode

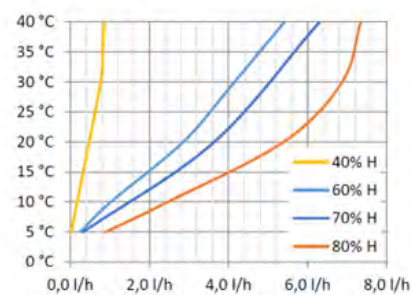

DH 20-35-65-120



Energy factor

DH 35

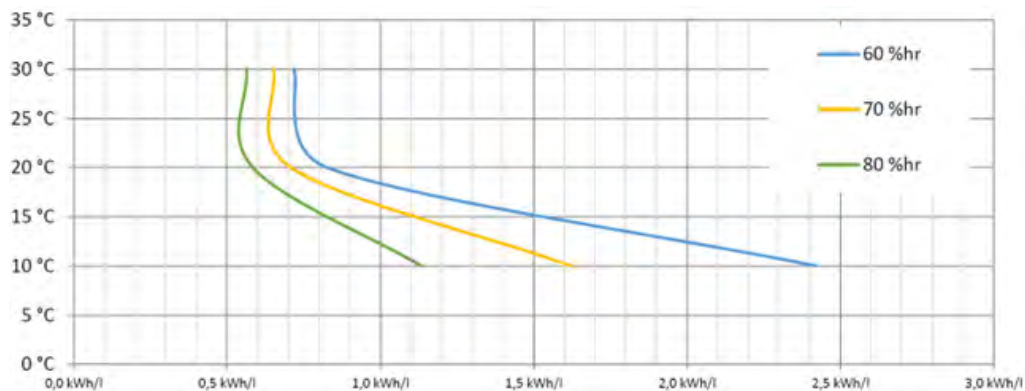

DH 65

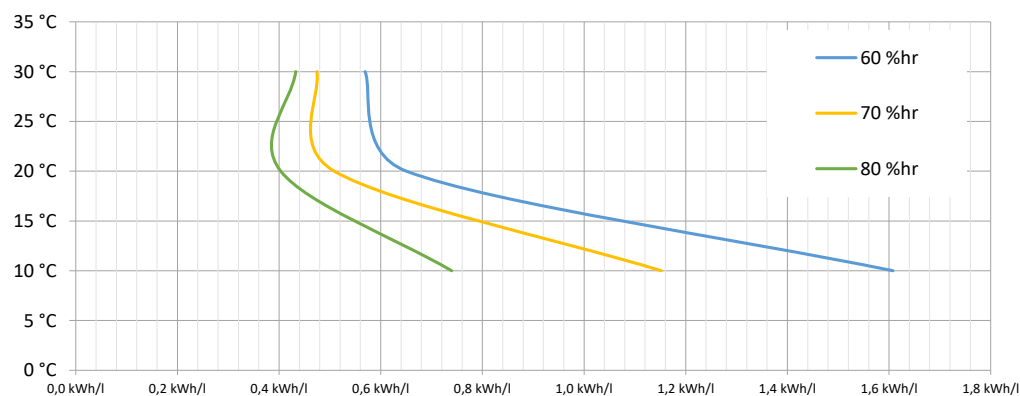

DH 120

"Comfort" mode

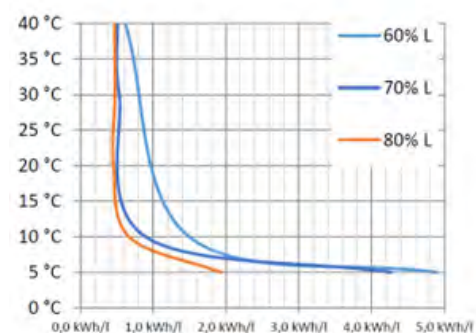

"Boost" mode

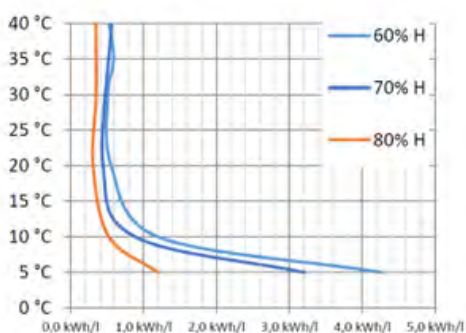

CALOREX DH 334



DH 334

The DH 334 process dryer is excellent for rapid moisture removal, at low cost per litre removed. Using R134a refrigerant it can operate at higher temperatures than standard dryers, and the latent energy is reclaimed to reduce the overall power consumption. The energy consumption is further reduced as drying can take place at lower temperatures than traditional heating methods, lowering risk of heat damage, and improving product quality.

- Rapid moisture removal at lowest cost per litre extracted
- Latent energy reclaimed to reduce power consumption
- Drying at lower temperatures reduces risk of heat damage
- Even drying improves product quality
- Low maintenance

Performance data

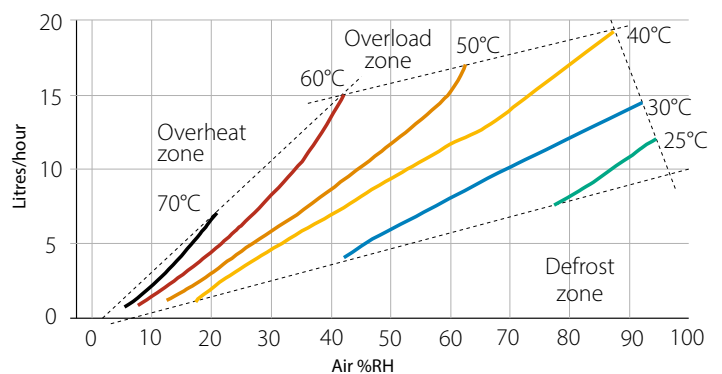

Specifications	Units	DH 334BH
Temperature range	°C	30-70
Dehumidification @ 50°C/60% RH	l/24h	360
Heat to air via dehumidification	kW	10
Heat to air via resistance heaters and dehumidification	kW	18.5
Air flow	m ³ /h	5,800
External static pressure	Pa	0
Sound pressure level @ 3m	dB(A)	69
Power supply	V/Hz	400/3ph/50
Nominal power consumed	kW	14.1
Min. supply capacity	A	29
Max. supply fuse	A	35
Heater rating	kW	9
Heater FLA	A	12
Compressor LRA	A	72
R134a gas weight/CO ₂ equivalent	kg/t	6.0/8.58
Product size (w x d x h)	mm	985 x 700 x 1476
Weight	kg	170

TTR 800



TTR 800

The TTR 800 desiccant dehumidifier provides high dehumidification capacity even in low dew points. Its stainless steel housing and IP53-designed electrical control box make it resistant to corrosion and harsh operational environments. It is ideal for a variety of drying tasks and dry air production in industries such as chemical, pharmaceutical, and mechanical engineering. It can also protect machines, inventory, and buildings from corrosion, condensation, and mould formation in facilities such as water processing and electrical control centres. The maintenance-friendly design makes it easy to use.



- Robust stainless steel housing
- Integrated G4 equivalent air filters as Z-line filters, separately for process and regeneration air
- Filter monitoring with warning light
- Rotor rotation control
- Potential-free signal contacts for maintenance/filter change, fault, operation ON/OFF
- Directly driven high-performance EC fans with manual speed adjustment integrated in the housing (no additional throttle valves required), separately for process and regeneration air
- Silica gel sorption rotor with internal purging sector for heat recovery and automatically adjusting rotor seal kit
- Temperature-controlled rundown period

Specifications	Units	TTR 800
Dehumidification capacity @ 20°C/60% RH	kg/h	3.6
Dry air flow free-blowing	m ³ /h	950
Dry air flow nominal	m ³ /h	750
Available pressure	Pa	300
Regeneration air flow	m ³ /h	130
Available pressure	Pa	300
Operating temperature range	°C	-20 to 40
Heating	kW	4.1
Power consumption	kW	4.9
Power supply	V/Hz	380-480/3ph/50-60+PE
Electrical connection	A	16
Nominal current consumption	A	7.5
Product size (l x w x h)	mm	734 x 649 x 942
Weight	kg	85
Connections dry air input/output	Ømm	250/250
Connections regeneration air input/output	Ømm	160/160

TTR 800



Dimensions (mm)

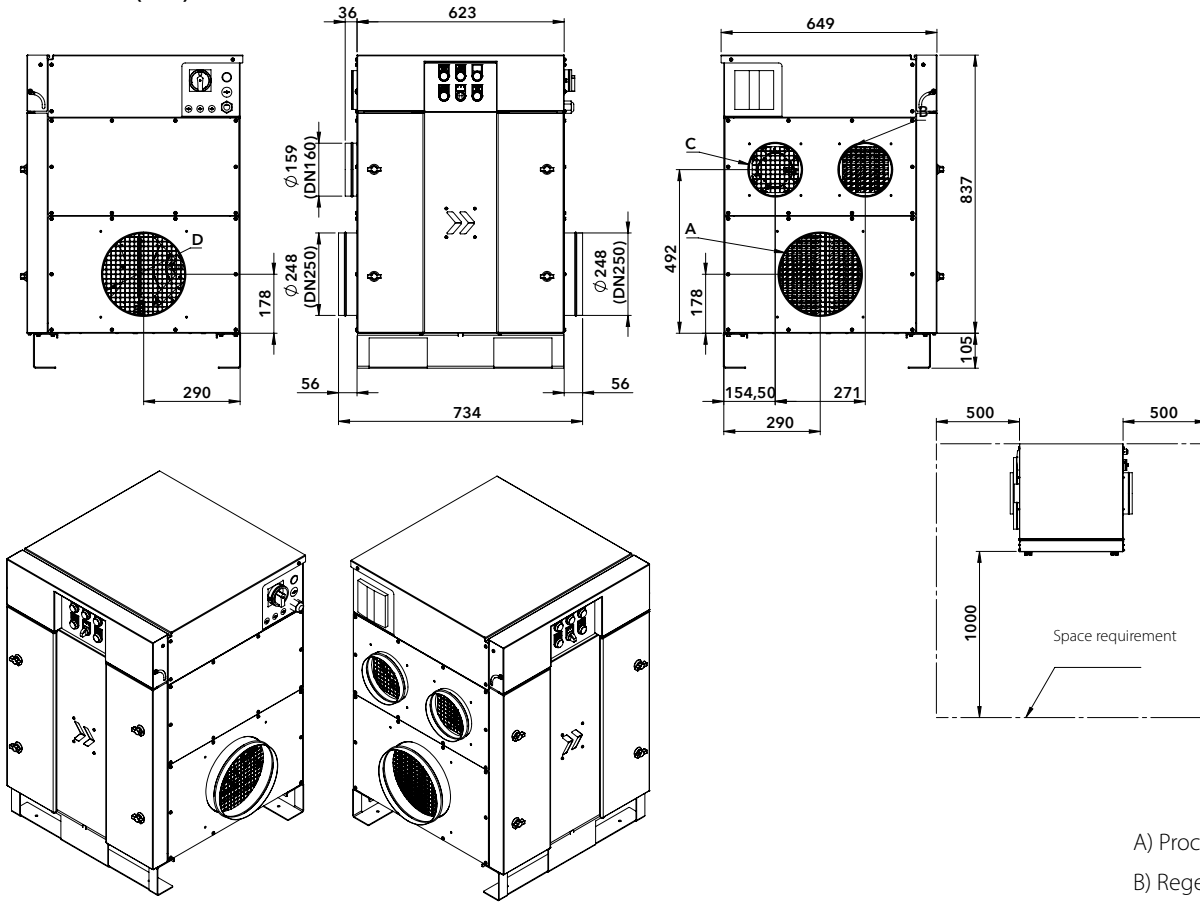

- A) Process air inlet
- B) Regeneration air inlet
- C) Humid air outlet
- D) Dry air outlet

Performance data

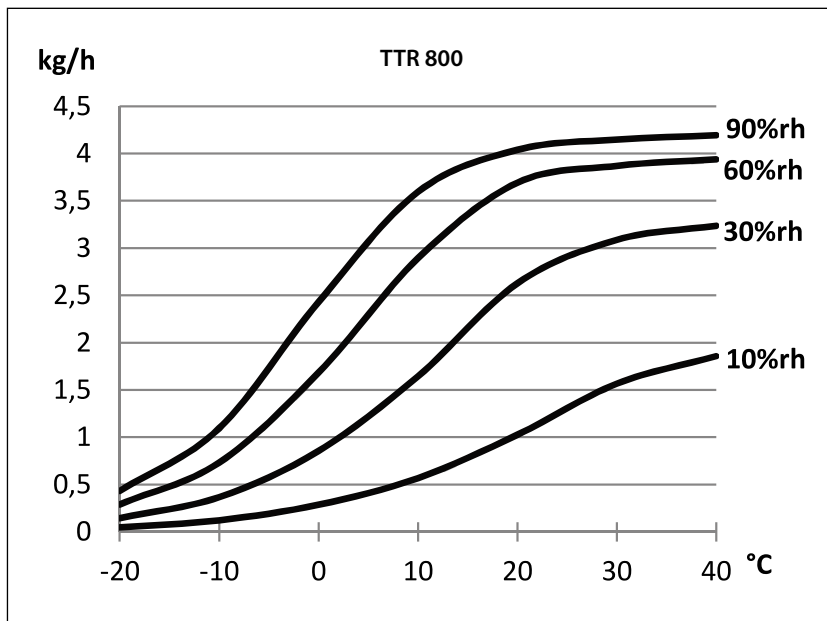

TTR 1400



TTR 1400

The TTR 1400 desiccant dehumidifier offers high dehumidification performance at low dew points, and its stainless steel housing and IP53 electrical control box make it ideal for use in harsh environments. It's suitable for dry keeping tasks or producing dry air in various industries such as chemical, pharmaceutical, and food. Additionally, it protects machines, inventory, and buildings from corrosion, condensation, and mould formation, making it perfect for use in water processing facilities or electrical control centres. The TTR 1400 is easy to maintain and provides effective dehumidification solutions.



- Robust stainless steel housing
- Integrated G4 equivalent air filters as Z-line filters, separately for process and regeneration air
- Filter monitoring with warning light
- Rotor rotation control
- Potential-free signal contacts for maintenance/filter change, fault, operation ON/OFF
- Directly driven high-performance EC fans with manual speed adjustment integrated in the housing (no additional throttle valves required), separately for process and regeneration air
- Silica gel sorption rotor with internal purging sector for heat recovery and automatically adjusting rotor seal kit
- Electric regeneration air heater comprising tubular heating elements, equipped with safety temperature limiters and differential pressure switch, controlled via semi-conductor relay(s)
- Temperature-controlled rundown period

Specifications	Units	TTR 1400
Dehumidification capacity @ 20°C/60% RH	kg/h	7.4
Dry air flow free-blowing	m ³ /h	1,750
Dry air flow nominal	m ³ /h	1,450
Available pressure	Pa	300
Regeneration air flow	m ³ /h	270
Available pressure	Pa	300
Operating temperature range	°C	-20 to 40
Heating	kW	9.0
Power consumption	kW	9.8
Power supply	V/Hz	380-480/3ph/50-60+PE
Electrical connection	A	16
Nominal current consumption	A	15
Product size (l x w x h)	mm	734 x 649 x 942
Weight	kg	100
Connections dry air input/output	Ømm	250/250
Connections regeneration air input/output	Ømm	160/160

TTR 1400



Dimensions (mm)

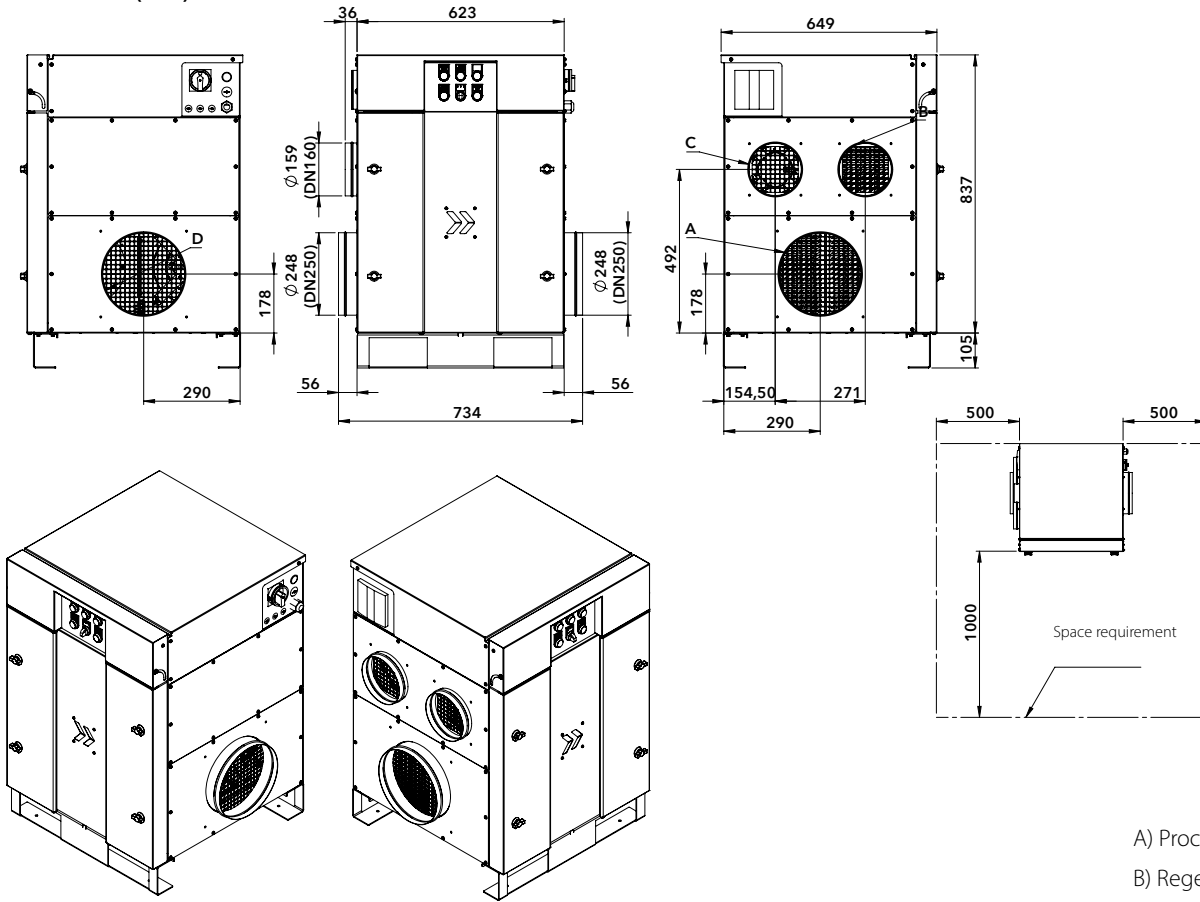

- A) Process air inlet
- B) Regeneration air inlet
- C) Humid air outlet
- D) Dry air outlet

Performance data

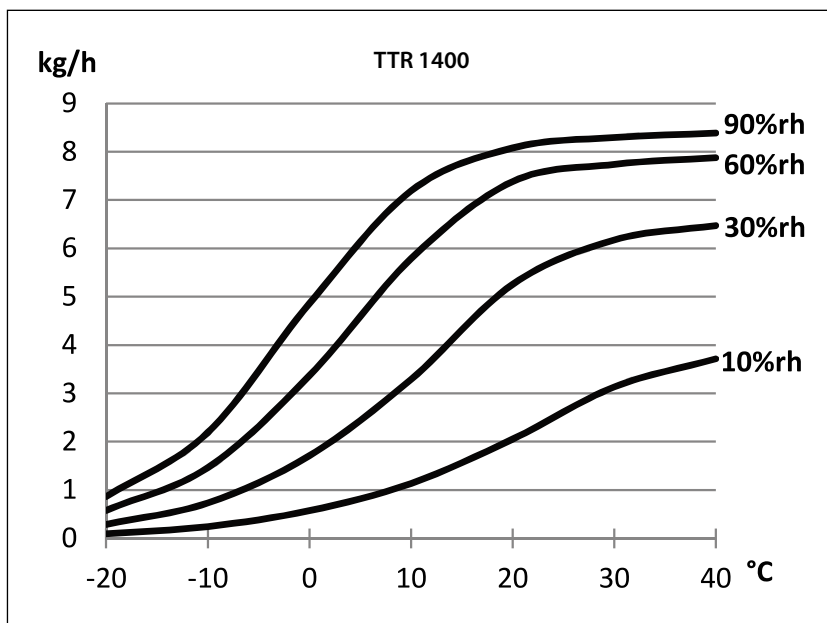

TTR 2000



TTR 2000

The TTR 2000 is an industrial desiccant dehumidifier that can handle several hundred kg of dehumidification performance per day, even in cold conditions with low dew points. This makes it an ideal solution for air and gas dehumidification tasks in various industries, such as securing products and production and protecting machines, inventory, and buildings from corrosion, condensation, or mould formation. The TTR 2000 comes with a standard stainless steel housing and an electrical control box with IP53 protection, which ensures it can withstand harsh environmental conditions and is suitable for dry keeping or the production of dry air in low temperatures or material-straining conditions, including hygiene-sensitive areas.



- Robust stainless steel housing
- Integrated G4 equivalent air filters as Z-line filters, separately for process and regeneration air
- Filter monitoring with warning light
- Rotor rotation control
- Potential-free signal contacts for maintenance/filter change, fault, operation ON/OFF
- Directly driven high-performance EC fans with manual speed adjustment integrated in the housing (no additional throttle valves required), separately for process and regeneration air
- Silica gel sorption rotor with internal purging sector for heat recovery and automatically adjusting rotor seal kit
- Electric regeneration air heater comprising tubular heating elements, equipped with safety temperature limiters and differential pressure switch, controlled via semi-conductor relay(s)
- Temperature-controlled rundown period

Specifications	Units	TTR 2000
Dehumidification capacity @ 20°C/60% RH	kg/h	10.8
Dry air flow free-blowing	m ³ /h	2,350
Dry air flow nominal	m ³ /h	2,000
Available pressure	Pa	300
Regeneration air flow	m ³ /h	380
Available pressure	Pa	250
Operating temperature range	°C	-20 to 40
Heating	kW	12.5
Power consumption	kW	15
Power supply	V/Hz	380-480/3ph/50-60+PE
Electrical connection	A	32
Nominal current consumption	A	23
Product size (l x w x h)	mm	1348 x 769 x 1323
Weight	kg	230
Connections dry air input/output	Ømm	315/315
Connections regeneration air input/output	Ømm	200/200

TTR 2000



Dimensions (mm)

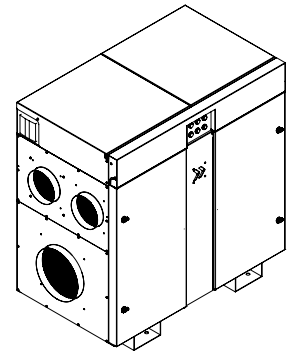
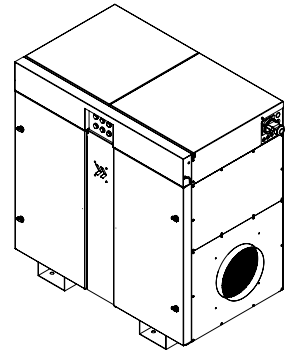
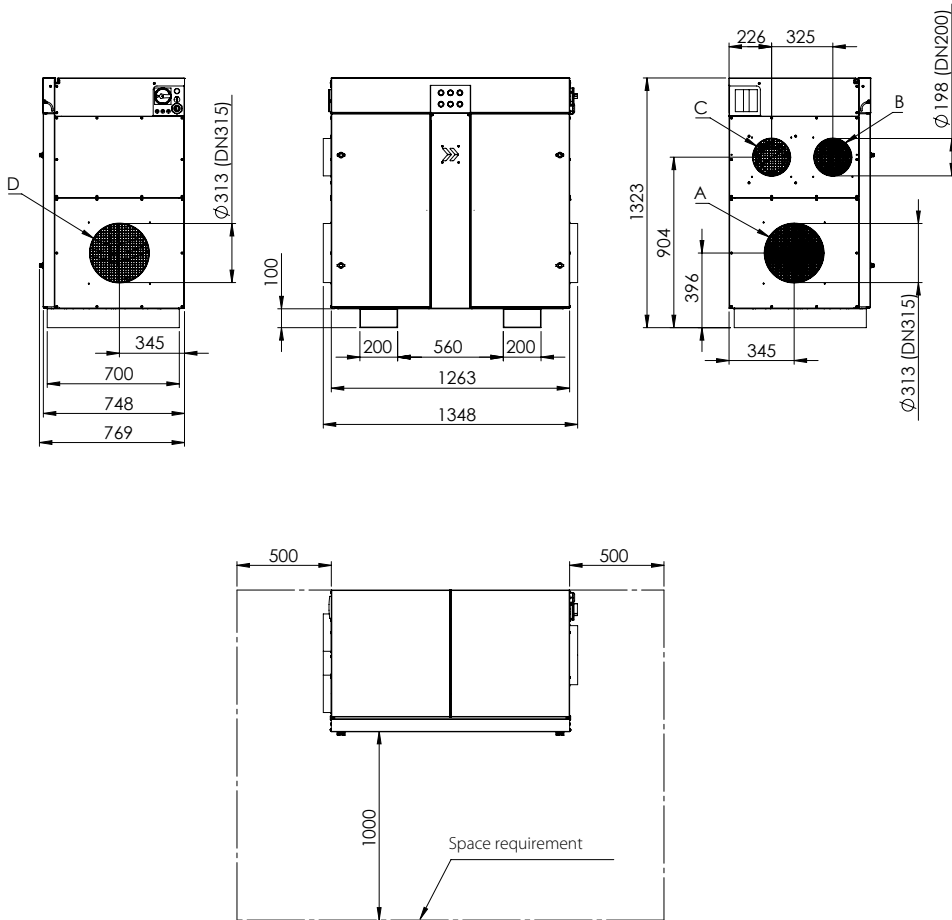

- A) Process air inlet
- B) Regeneration air inlet
- C) Humid air outlet
- D) Dry air outlet

Performance data

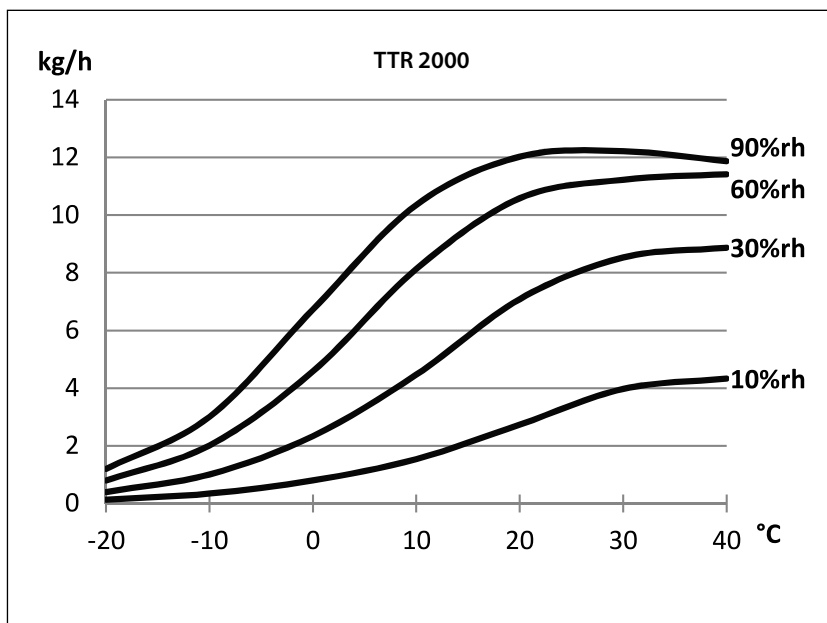

TTR 2800



TTR 2800

The TTR 2800 industrial desiccant dehumidifier can handle nearly 400kg of dehumidification performance per day, even in cold ambient conditions with low dew points. This makes it an ideal solution for various air and gas dehumidification tasks in industrial, haulage, or utility companies to protect products, machines, inventory, and buildings against corrosion, condensation, or mould formation. The TTR 2800 has a standard stainless steel housing and an electrical control box with IP53 protection, making it corrosion-proof and suitable for dry keeping or producing dry air at low temperatures or under material-straining conditions, including hygiene-sensitive areas.



- Robust stainless steel housing
- Integrated G4 equivalent air filters as Z-line filters, separately for process and regeneration air
- Filter monitoring with warning light
- Rotor rotation control
- Potential-free signal contacts for maintenance/filter change, fault, operation ON/OFF
- Directly driven high-performance EC fans with manual speed adjustment integrated in the housing (no additional throttle valves required), separately for process and regeneration air
- Silica gel sorption rotor with internal purging sector for heat recovery and automatically adjusting rotor seal kit
- Electric regeneration air heater comprising tubular heating elements, equipped with safety temperature limiters and differential pressure switch, controlled via semi-conductor relay(s)
- Temperature-controlled rundown period

Specifications	Units	TTR 2800
Dehumidification capacity @ 20°C/60% RH	kg/h	15.7
Dry air flow free-blowing	m ³ /h	3,150
Dry air flow nominal	m ³ /h	2,800
Available pressure	Pa	300
Regeneration air flow	m ³ /h	570
Available pressure	Pa	300
Operating temperature range	°C	-20 to 40
Heating	kW	18.9
Power consumption	kW	21.6
Power supply	V/Hz	380-480/3ph/50-60+PE
Electrical connection	A	32
Nominal current consumption	A	31.7
Product size (l x w x h)	mm	1348 x 769 x 1323
Weight	kg	250
Connections dry air input/output	Ømm	315/315
Connections regeneration air input/output	Ømm	200/200

TTR 2800



Dimensions (mm)

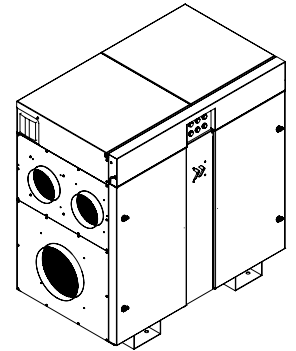
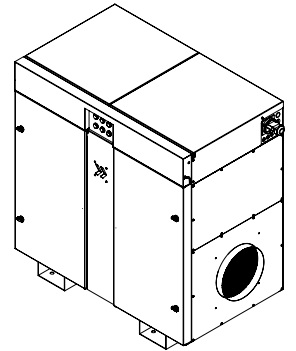
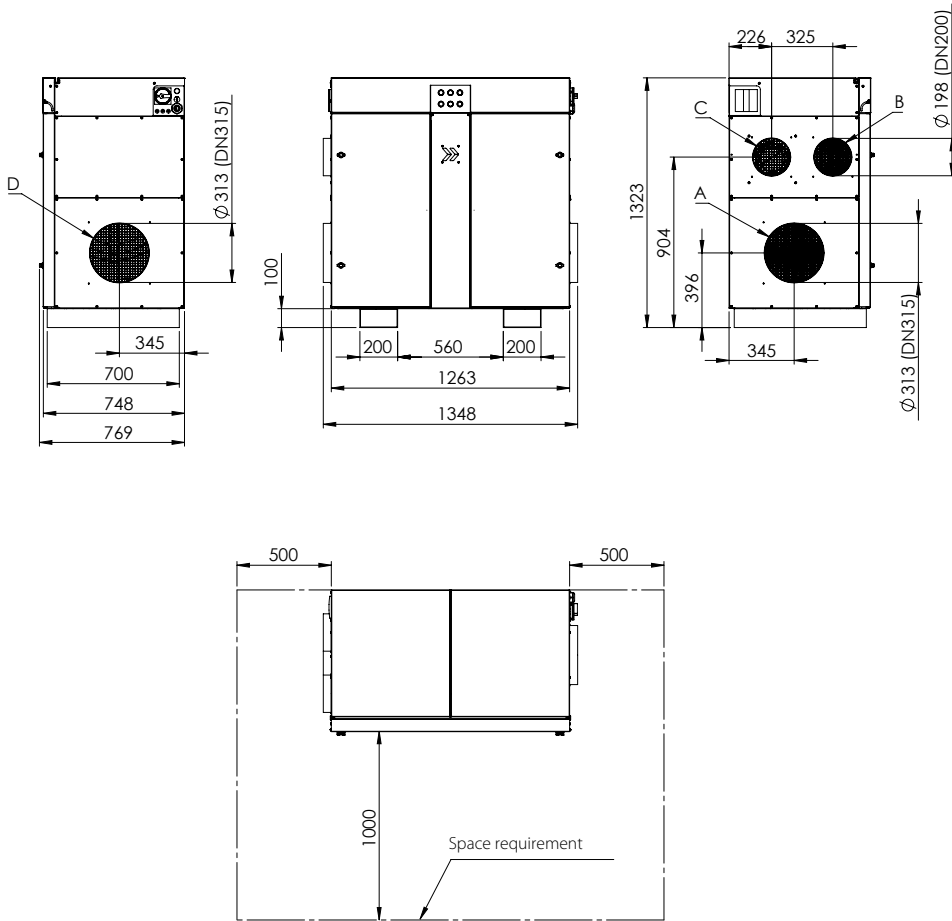

- A) Process air inlet
- B) Regeneration air inlet
- C) Humid air outlet
- D) Dry air outlet

Performance data

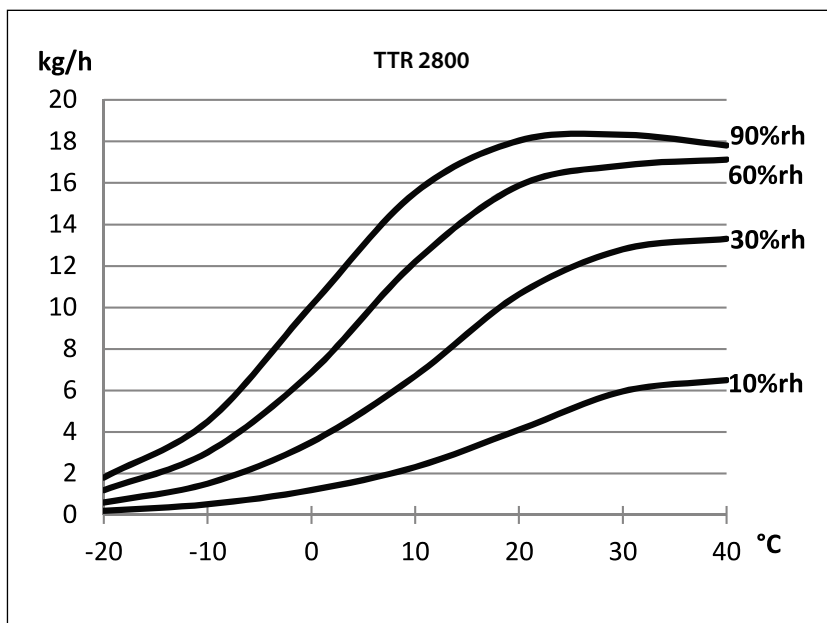

TTR 3700



TTR 3700

The TTR 3700 is an industrial desiccant dehumidifier that can handle up to 500kg of dehumidification performance per day, even in cold environments with low dew points. It is ideal for various dehumidification tasks in industrial, haulage or utility companies, such as protecting products and production, and retaining the value of machines, inventory, and buildings by preventing corrosion, condensation or mould formation. With its stainless steel housing and IP53 electrical control box, the TTR 3700 can withstand harsh environmental conditions, making it suitable for dry keeping or producing dry air under material-straining conditions in hygiene-sensitive areas.



- Stainless steel housing
- Integrated G4 equivalent air filters as Z-line filters, separately for process and regeneration air
- Filter monitoring with warning light
- Rotor rotation control
- Potential-free signal contacts for maintenance/filter change, fault, operation ON/OFF
- Directly driven high-performance EC fans with manual speed adjustment integrated in the housing (no additional throttle valves required), separately for process and regeneration air
- Silica gel sorption rotor with internal purging sector for heat recovery and automatically adjusting rotor seal kit
- Housing prepared for mirror-inverted assembly; air direction reversal; standard process air flow direction from left to right)
- Temperature-controlled rundown period

Specifications	Units	TTR 3700
Dehumidification capacity @ 20°C/60% RH	kg/h	20.5
Dry air flow free-blowing	m ³ /h	4,300
Dry air flow nominal	m ³ /h	3,700
Available pressure	Pa	400
Regeneration air flow	m ³ /h	740
Available pressure	Pa	200
Operating temperature range	°C	-20 to 40
Heating	kW	24.5
Power consumption	kW	28.8
Power supply	V/Hz	380-480/3ph/50-60+PE
Electrical connection	A	63
Nominal current consumption	A	42.8
Product size (l x w x h)	mm	1348 x 769 x 1323
Weight	kg	270
Connections dry air input/output	Ømm	315/315
Connections regeneration air input/output	Ømm	200/200

TTR 3700



Dimensions (mm)

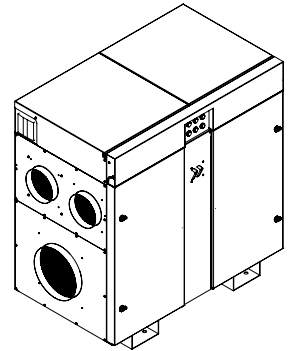
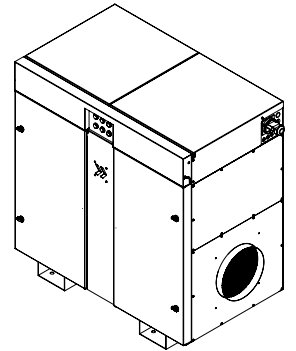
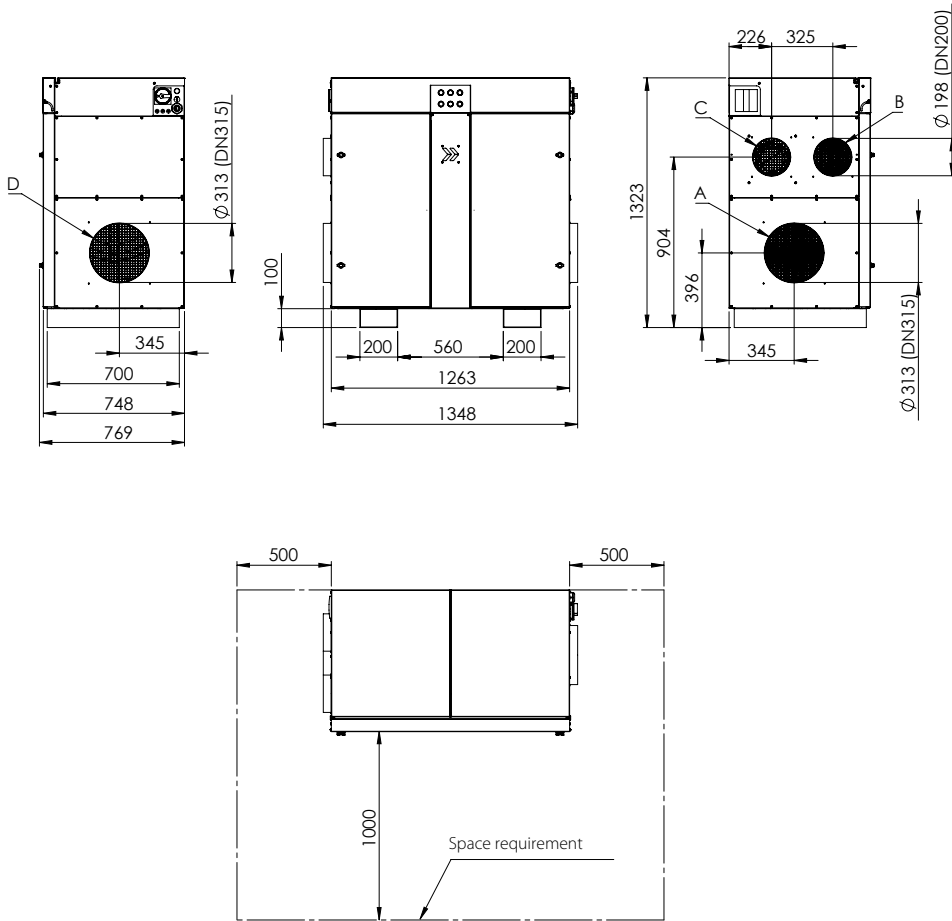

- A) Process air inlet
- B) Regeneration air inlet
- C) Humid air outlet
- D) Dry air outlet

Performance data

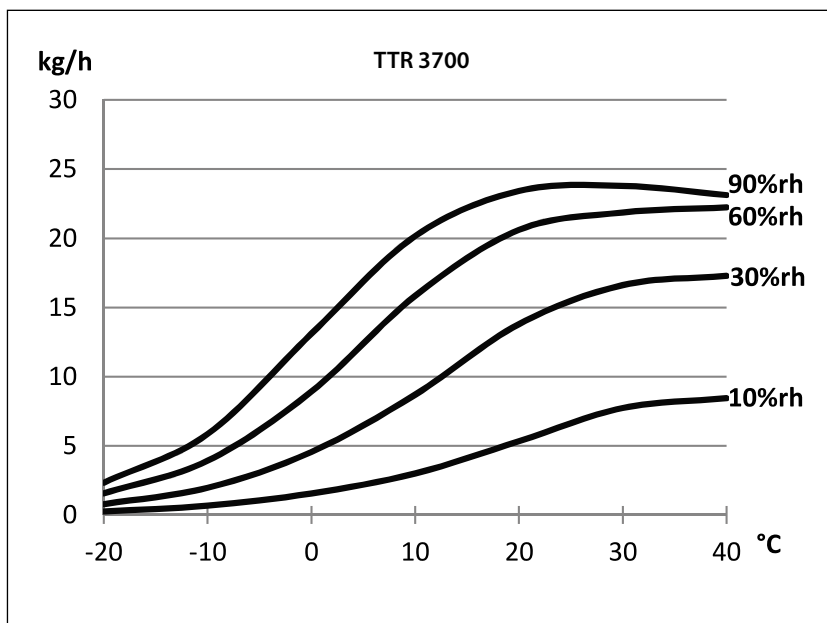

**TTR 5200**

The TTR 5200 is an excellent dehumidification solution for industrial applications that require large dry air volumes, low dew points, and continuous control. It is ideal for preventing corrosion damage caused by condensate, ensuring the quality of stored goods, maintaining ice-free cooling zones, and accelerating drying processes. The robust and corrosion-protected galvanised steel housing of the TTR 5200 can withstand even the toughest environmental conditions, making it suitable for various industries, including chemical, pharmaceutical, food, mechanical engineering, and deep-freeze storage.

- Housing made of powder-coated, galvanised sheet steel
- Integrated G4 equivalent air filters as Z-line filters, separately for process and regeneration air
- Filter monitoring with warning light
- Rotor rotation control
- Potential-free signal contacts for maintenance/filter change, fault, operation ON/OFF
- Directly driven high-performance EC fans with manual speed adjustment integrated in the housing (no additional throttle valves required), separately for process and regeneration air
- Flowmatic S, separate electronic fan speed control for process and regeneration air, controlled to a constant volumetric flow or pressure depending on the process-related target value, control signal 0...10 V or 4–20 mA
- Silica gel sorption rotor with internal purging sector for heat recovery and automatically adjusting rotor seal kit
- Control with four-line plain text display
- Temperature-controlled rundown period

Specifications	Units	TTR 5200
Dehumidification capacity @ 20°C/60% RH	kg/h	29.1
Dry air flow free-blowing	m ³ /h	5,800
Dry air flow nominal	m ³ /h	5,200
Available pressure	Pa	400
Regeneration air flow	m ³ /h	1,050
Available pressure	Pa	300
Operating temperature range	°C	-20 to 40
Heating	kW	36.0
Power consumption	kW	40.0
Power supply	V/Hz	380-480/3ph/50-60+PE
Electrical connection	A	63
Nominal current consumption	A	60
Product size (l x w x h)	mm	1919 x 1100 x 1680
Weight	kg	680
Connections dry air input/output	Ømm	500/500
Connections regeneration air input/output	Ømm	300/300

TTR 5200



Dimensions (mm)

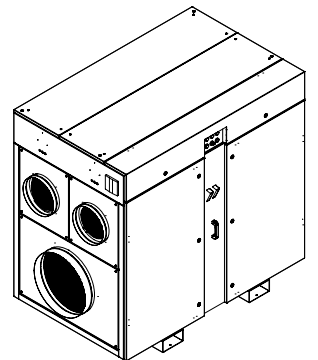
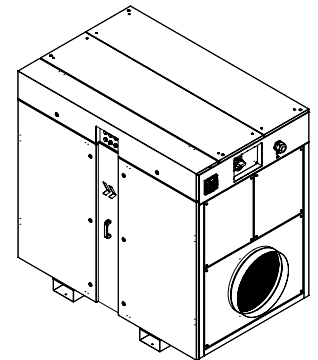
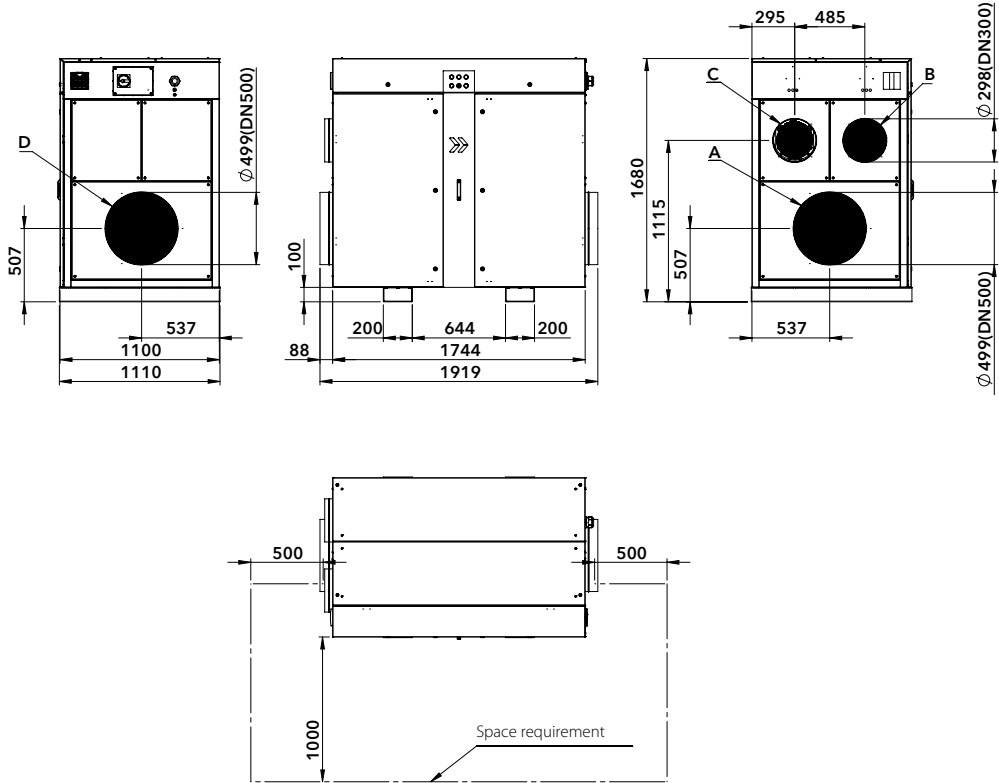

- A) Process air inlet
- B) Regeneration air inlet
- C) Humid air outlet
- D) Dry air outlet

Performance data

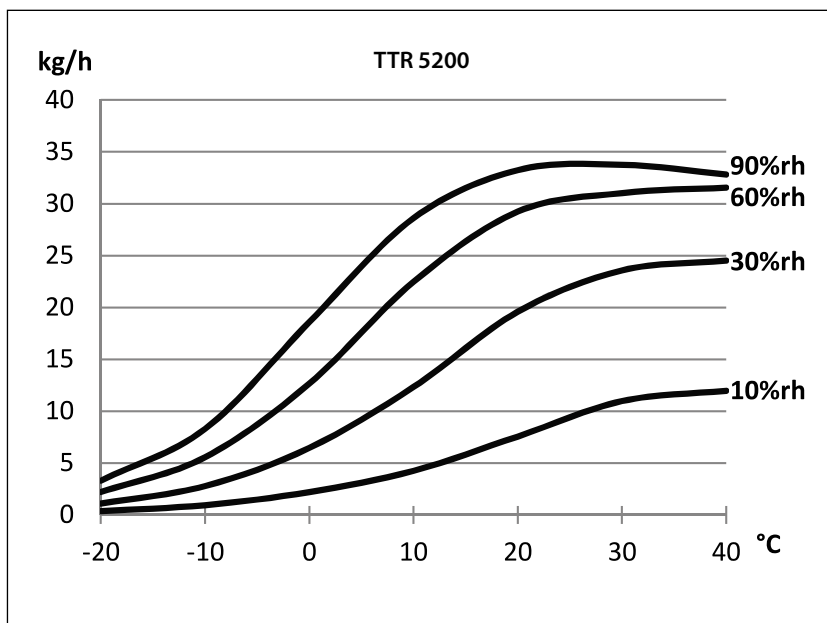

TTR 6600**TTR 6600**

The TTR 6600 industrial desiccant dehumidifier has approximately 900kg of dehumidification performance per day and a nominal air volume of 6,600 cubic metres of dry air per hour at a static pressure of 400 Pa, making it suitable for high dry air demand in cold surroundings with low dew points. It is ideal for permanent dry keeping, gas dehumidification, or dry air production in the chemical, pharmaceutical, and food industry, mechanical engineering, or protecting machines, inventory, and buildings from corrosion, condensation, or mould formation in water processing facilities or electrical control centres.

- Housing made of powder-coated, galvanised sheet steel
- Integrated G4 equivalent air filters as Z-line filters, separately for process and regeneration air
- Filter monitoring with warning light
- Rotor rotation control
- Potential-free signal contacts for maintenance/filter change, fault, operation ON/OFF
- Directly driven high-performance EC fans with manual speed adjustment integrated in the housing (no additional throttle valves required), separately for process and regeneration air
- Flowmatic S, separate electronic fan speed control for process and regeneration air, controlled to a constant volumetric flow or pressure depending on the process-related target value, control signal 0...10 V or 4–20 mA
- Silica gel sorption rotor with internal purging sector for heat recovery and automatically adjusting rotor seal kit
- Control with four-line plain text display
- Temperature-controlled rundown period

Specifications	Units	TTR 6600
Dehumidification capacity @ 20°C/60% RH	kg/h	37.2
Dry air flow free-blowing	m ³ /h	7,200
Dry air flow nominal	m ³ /h	6,600
Available pressure	Pa	400
Regeneration air flow	m ³ /h	1,330
Available pressure	Pa	300
Operating temperature range	°C	-20 to 40
Heating	kW	45.0
Power consumption	kW	50.5
Power supply	V/Hz	380-480/3ph/50-60+PE
Electrical connection	A	100
Nominal current consumption	A	73.5
Product size (l x w x h)	mm	1919 x 1100 x 1680
Weight	kg	720
Connections dry air input/output	Ømm	500/500
Connections regeneration air input/output	Ømm	300/300

TTR 6600



Dimensions (mm)

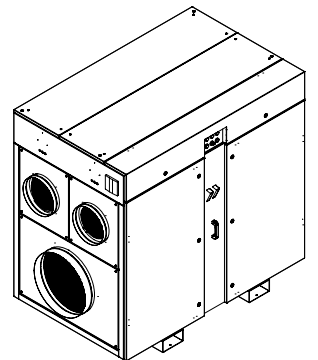
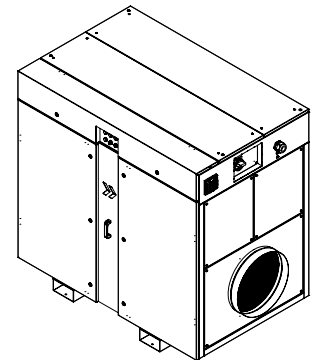
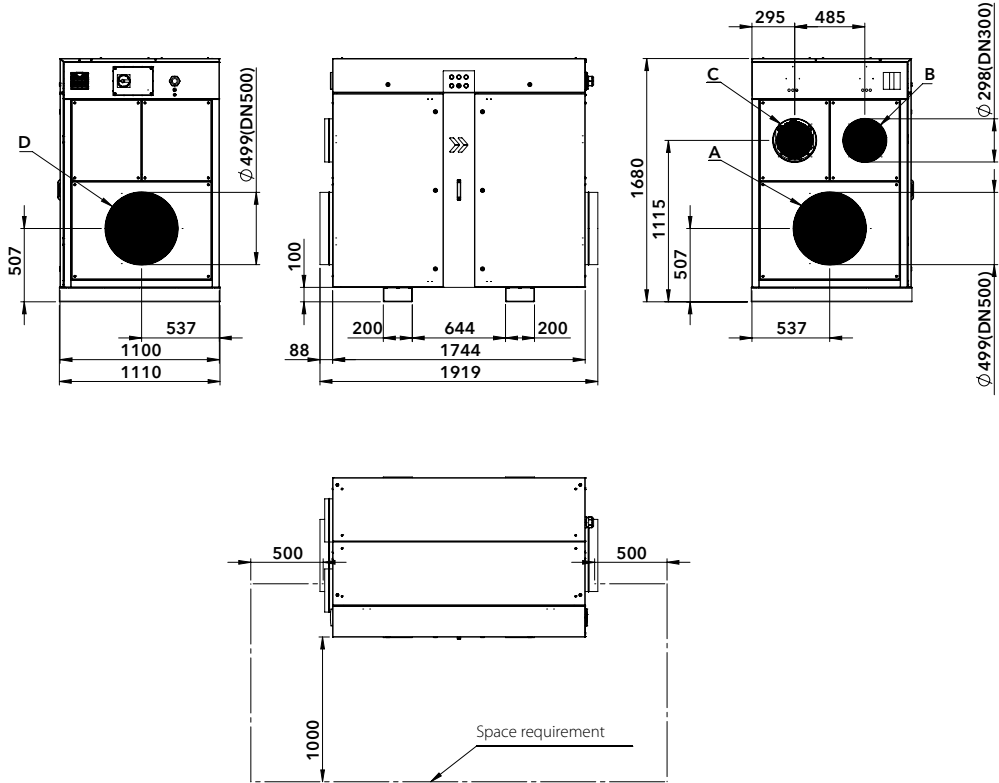

- A) Process air inlet
- B) Regeneration air inlet
- C) Humid air outlet
- D) Dry air outlet

Performance data

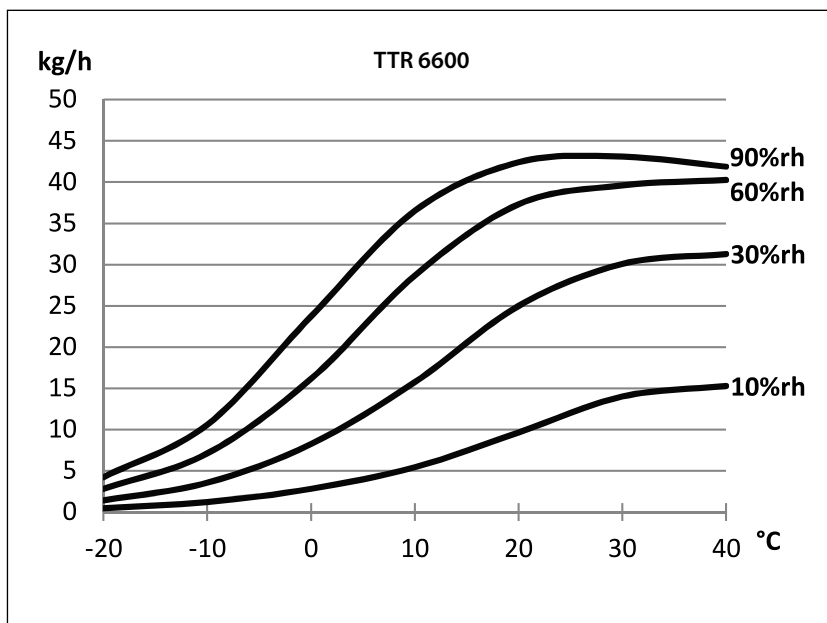

TTR 8200**TTR 8200**

The TTR 8200 industrial desiccant dehumidifier offers over 1,000kg of dehumidification performance per day, making it ideal for various tasks in industrial, haulage, or utility companies. It can protect products and production, as well as machines, inventory, and buildings from corrosion, condensation, or mould formation. Its robust, galvanised, and painted steel housing with corrosion protection can withstand harsh environmental conditions, making it suitable for dry keeping, gas dehumidification, or dry air production in the chemical, pharmaceutical, and food industries, mechanical engineering, or reducing the formation of ice and frost in deep-freeze zones. It can also protect stored goods susceptible to moisture.

- Housing made of powder-coated, galvanised sheet steel
- Integrated G4 equivalent air filters as Z-line filters, separately for process and regeneration air
- Filter monitoring with warning light
- Rotor rotation control
- Potential-free signal contacts for maintenance/filter change, fault, operation ON/OFF
- Directly driven high-performance EC fans with manual speed adjustment integrated in the housing (no additional throttle valves required), separately for process and regeneration air
- Flowmatic S, separate electronic fan speed control for process and regeneration air, controlled to a constant volumetric flow or pressure depending on the process-related target value, control signal 0...10 V or 4–20 mA
- Silica gel sorption rotor with internal purging sector for heat recovery and automatically adjusting rotor seal kit
- Control with four-line plain text display
- Temperature-controlled rundown period

Specifications	Units	TTR 8200
Dehumidification capacity @ 20°C/60% RH	kg/h	46.2
Dry air flow free-blowing	m ³ /h	9,000
Dry air flow nominal	m ³ /h	8,200
Available pressure	Pa	400
Regeneration air flow	m ³ /h	1,660
Available pressure	Pa	300
Operating temperature range	°C	-20 to 40
Heating	kW	57.0
Power consumption	kW	64.5
Power supply	V/Hz	380-480/3ph/50-60+PE
Electrical connection	A	125
Nominal current consumption	A	93.5
Product size (l x w x h)	mm	1919 x 1100 x 1680
Weight	kg	750
Connections dry air input/output	Ømm	500/500
Connections regeneration air input/output	Ømm	300/300

TTR 8200



Dimensions (mm)

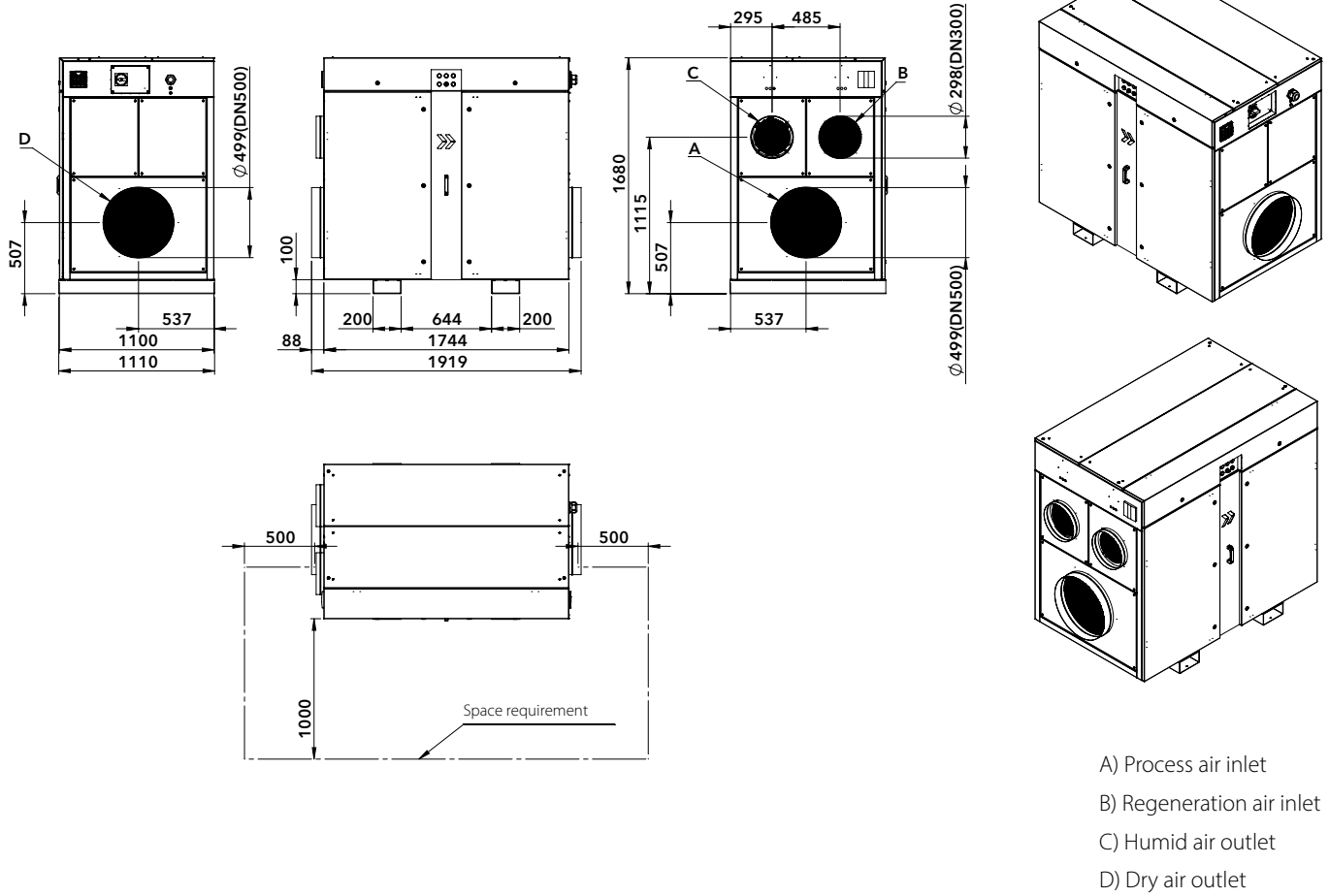

Performance data

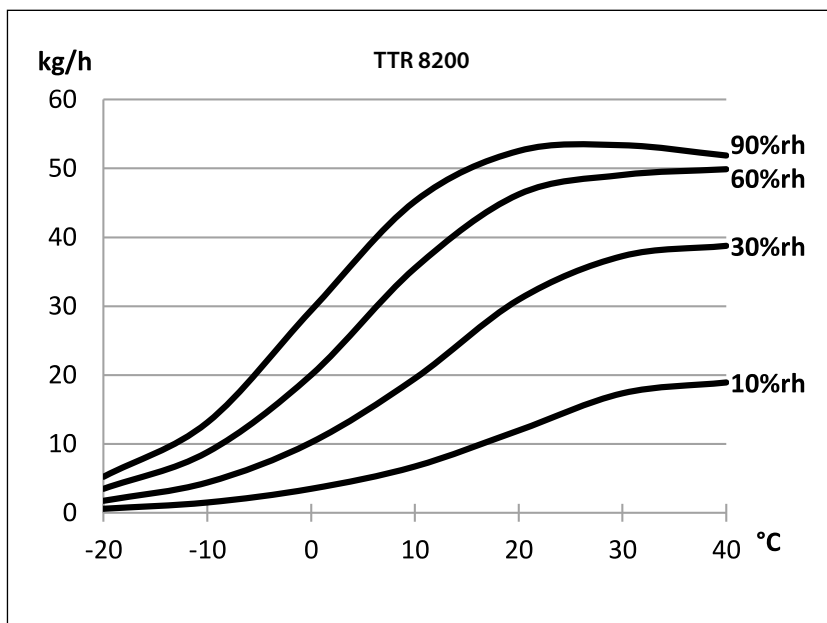

**TTR 10000**

The TTR 10000 is an ideal solution for high dry air demand in cold environments with low dew points. It has a dehumidification performance of 1,322kg per day and can deliver 9,800 cubic metres of dry air per hour at a static pressure of 300 Pa. This German-made dehumidifier is well-suited for permanent dry keeping, gas dehumidification, and dry air production in the chemical, pharmaceutical, and food industries, as well as mechanical engineering. It is also effective in protecting machines, inventory, and buildings from corrosion, condensation, and mould formation, particularly in water processing facilities or electrical control centres.

- Housing made of powder-coated, galvanised sheet steel
- Integrated G4 equivalent air filters as Z-line filters, separately for process and regeneration air
- Filter monitoring with warning light
- Rotor rotation control
- Potential-free signal contacts for maintenance/filter change, fault, operation ON/OFF
- Directly driven high-performance EC fans with manual speed adjustment integrated in the housing (no additional throttle valves required), separately for process and regeneration air
- Flowmatic S, separate electronic fan speed control for process and regeneration air, controlled to a constant volumetric flow or pressure depending on the process-related target value, control signal 0...10 V or 4–20 mA
- Silica gel sorption rotor with internal purging sector for heat recovery and automatically adjusting rotor seal kit
- Control with four-line plain text display
- Temperature-controlled rundown period

Specifications	Units	TTR 10000
Dehumidification capacity @ 20°C/60% RH	kg/h	55.1
Dry air flow free-blowing	m ³ /h	10,500
Dry air flow nominal	m ³ /h	9,800
Available pressure	Pa	300
Regeneration air flow	m ³ /h	1,970
Available pressure	Pa	300
Operating temperature range	°C	-20 to 40
Heating	kW	66.0
Power consumption	kW	74.0
Power supply	V/Hz	380-480/3ph/50-60+PE
Electrical connection	A	160
Nominal current consumption	A	108
Product size (l x w x h)	mm	2032 x 1460 x 1802
Weight	kg	900
Connections dry air input/output	Ømm	optional 2 x 500
Connections regeneration air input/output	Ømm	400/400

TTR 10000



Dimensions (mm)

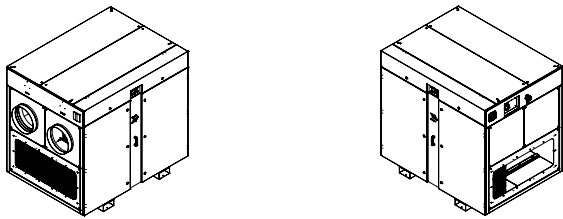
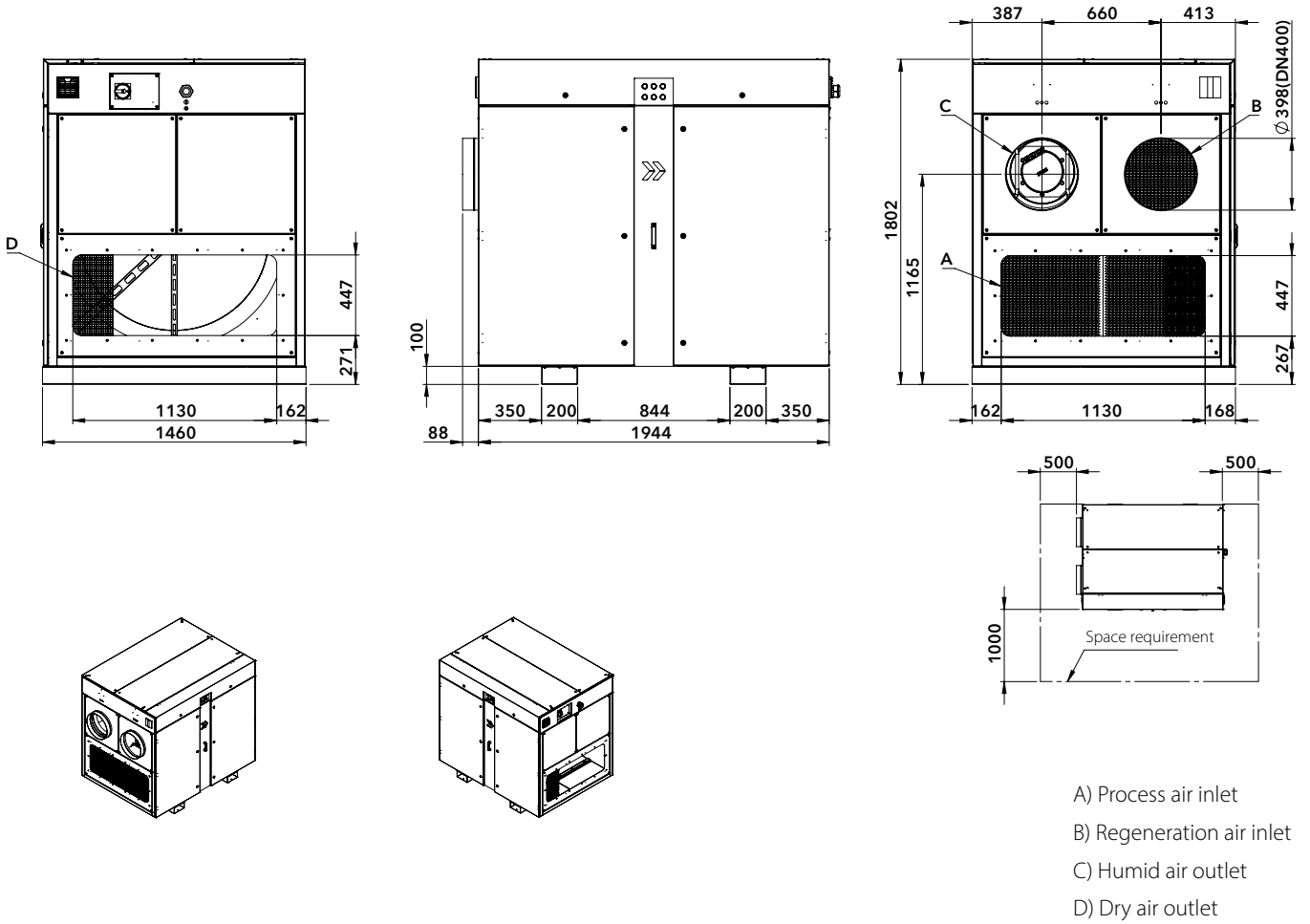

- A) Process air inlet
- B) Regeneration air inlet
- C) Humid air outlet
- D) Dry air outlet

Performance data

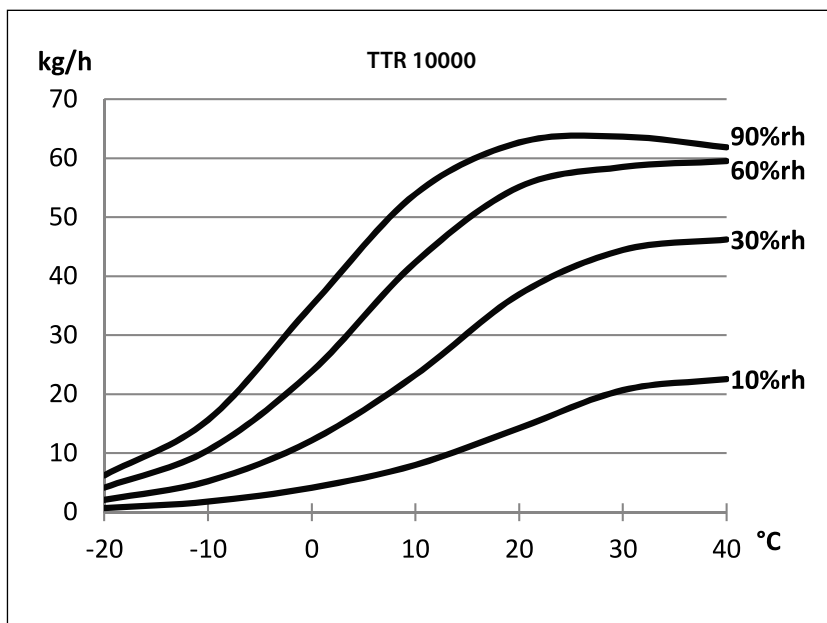

TTR 12000**TTR 12000**

The TTR 12000 is a German-manufactured, highly reliable and powerful desiccant dehumidifier suitable for various industries such as chemical, pharmaceutical, and food production, mechanical engineering, and water processing facilities or electrical control centres. It can also protect machines, inventory, and buildings from corrosion, condensation, and mould formation. The TTR 12000 has a dehumidification performance of 1,596kg per day, a nominal air volume of 11,800 cubic metres of dry air per hour at a static pressure of 300 Pa, making it ideal for high dry air demand in cold environments with low dew points.

- Housing made of powder-coated, galvanised sheet steel
- Integrated G4 equivalent air filters as Z-line filters, separately for process and regeneration air
- Filter monitoring with warning light
- Rotor rotation control
- Potential-free signal contacts for maintenance/filter change, fault, operation ON/OFF
- Directly driven high-performance EC fans with manual speed adjustment integrated in the housing (no additional throttle valves required), separately for process and regeneration air
- Flowmatic S, separate electronic fan speed control for process and regeneration air, controlled to a constant volumetric flow or pressure depending on the process-related target value, control signal 0... 10 V or 4–20 mA
- Silica gel sorption rotor with internal purging sector for heat recovery and automatically adjusting rotor seal kit
- Control with four-line plain text display
- Temperature-controlled rundown period

Specifications	Units	TTR 12000
Dehumidification capacity @ 20°C/60% RH	kg/h	66.5
Dry air flow free-blowing	m ³ /h	12,500
Dry air flow nominal	m ³ /h	11,800
Available pressure	Pa	300
Regeneration air flow	m ³ /h	2,380
Available pressure	Pa	300
Operating temperature range	°C	-20 to 40
Heating	kW	81.0
Power consumption	kW	89.0
Power supply	V/Hz	380-480/3ph/50-60+PE
Electrical connection	A	160
Nominal current consumption	A	129
Product size (l x w x h)	mm	2032 x 1460 x 1802
Weight	kg	1,000
Connections dry air input/output	Ømm	optional 2 x 500
Connections regeneration air input/output	Ømm	400/400

TTR 12000



Dimensions (mm)

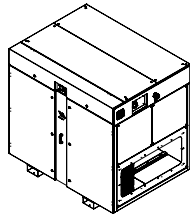
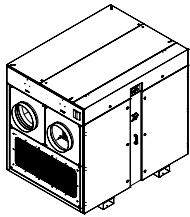
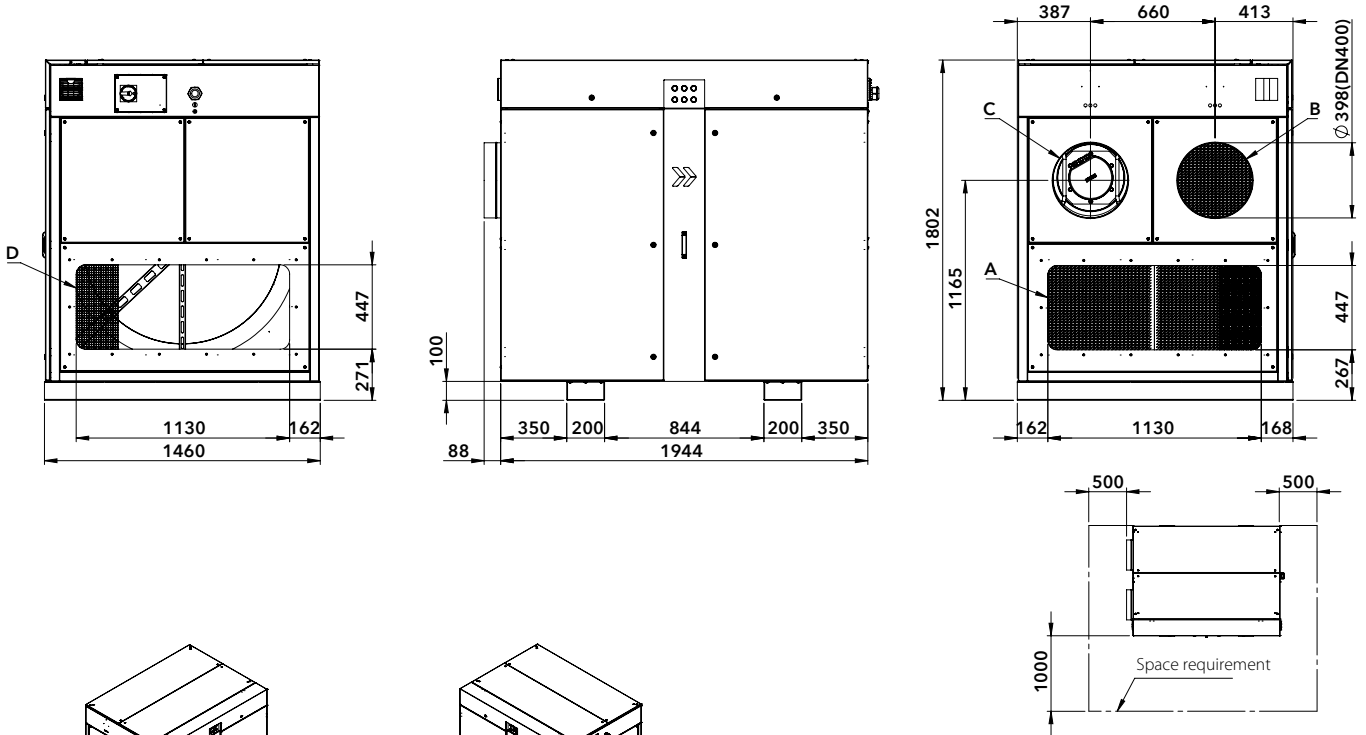

- A) Process air inlet
- B) Regeneration air inlet
- C) Humid air outlet
- D) Dry air outlet

Performance data

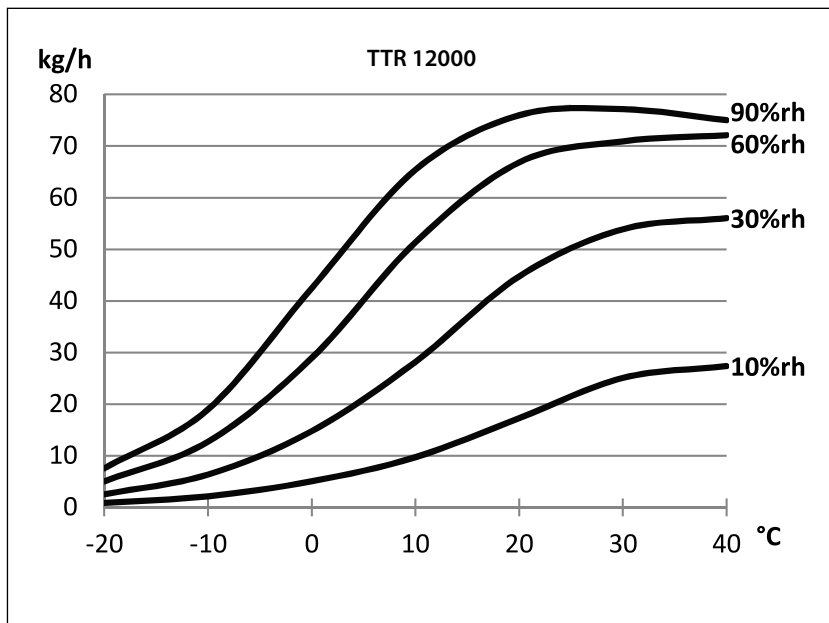

TTR 13500**TTR 13500**

The TTR 13500 has a dehumidification performance of 1,790kg per day and can deliver 13,300 cubic metres of dry air per hour at a static pressure of 400Pa. It is ideal for situations requiring high levels of dry air in cold environments with low dew points. This makes it suitable for a range of industries including chemical, pharmaceutical, and food production, as well as for protecting machines, inventory, and buildings from damage caused by corrosion, condensation, and mould formation. It is especially useful in water processing facilities and electrical control centres.

- Housing made of powder-coated, galvanised sheet steel
- Integrated G4 equivalent air filters as Z-line filters, separately for process and regeneration air
- Filter monitoring with warning light
- Rotor rotation control
- Potential-free signal contacts for maintenance/filter change, fault, operation ON/OFF
- Directly driven high-performance EC fans with manual speed adjustment integrated in the housing (no additional throttle valves required), separately for process and regeneration air
- Flowmatic S, separate electronic fan speed control for process and regeneration air, controlled to a constant volumetric flow or pressure depending on the process-related target value, control signal 0...10V or 4–20 mA
- Silica gel sorption rotor with internal purging sector for heat recovery and automatically adjusting rotor seal kit
- Control with four-line plain text display
- Temperature-controlled rundown period

Specifications	Units	TTR 13500
Dehumidification capacity @ 20°C/60% RH	kg/h	74.6
Dry air flow free-blowing	m ³ /h	14,700
Dry air flow nominal	m ³ /h	13,300
Available pressure	Pa	400
Regeneration air flow	m ³ /h	2,670
Available pressure	Pa	200
Operating temperature range	°C	-20 to 40
Heating	kW	90.0
Power consumption	kW	103.0
Power supply	V/Hz	380-480/3ph/50-60+PE
Electrical connection	A	250
Nominal current consumption	A	150
Product size (l x w x h)	mm	2032 x 1460 x 1802
Weight	kg	1,100
Connections dry air input/output	Ømm	optional 2 x 500
Connections regeneration air input/output	Ømm	400/400

TTR 13500



Dimensions (mm)

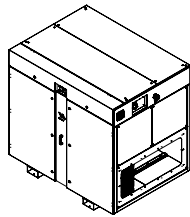
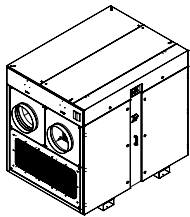
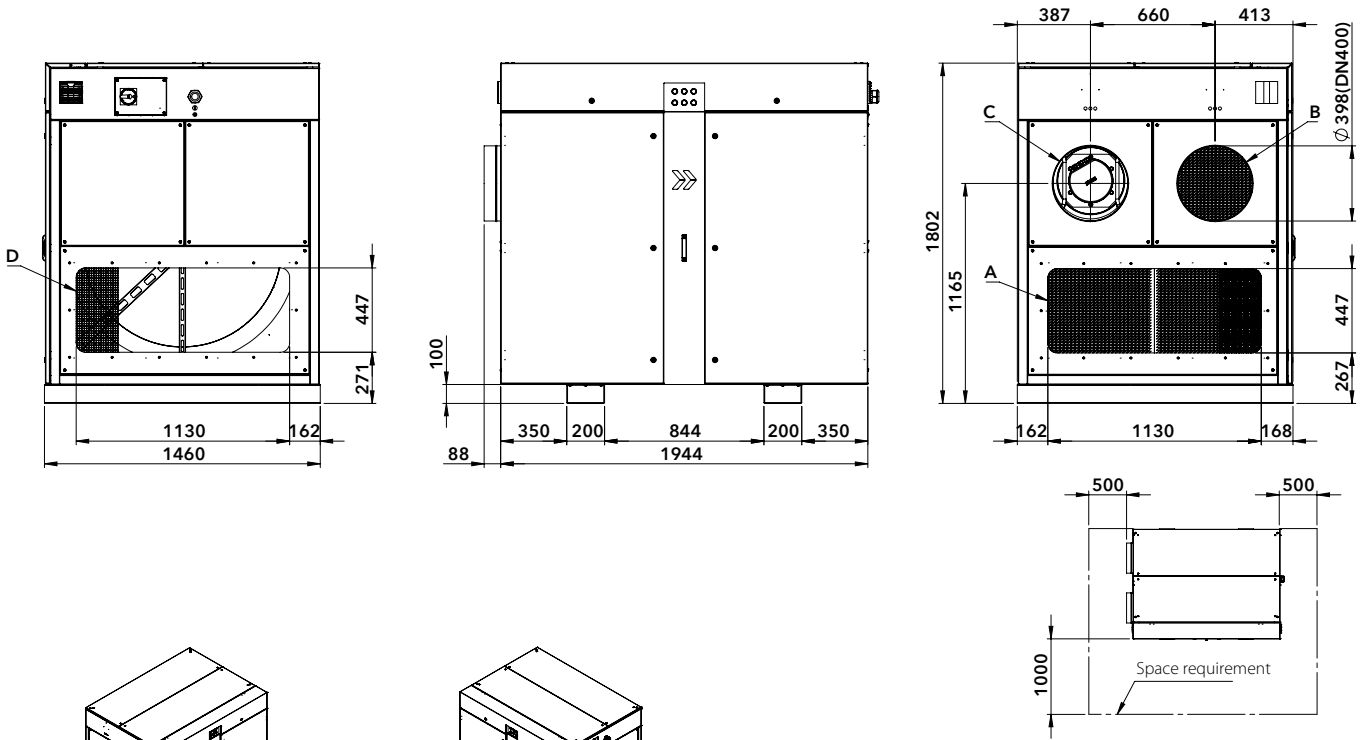

- A) Process air inlet
- B) Regeneration air inlet
- C) Humid air outlet
- D) Dry air outlet

Performance data

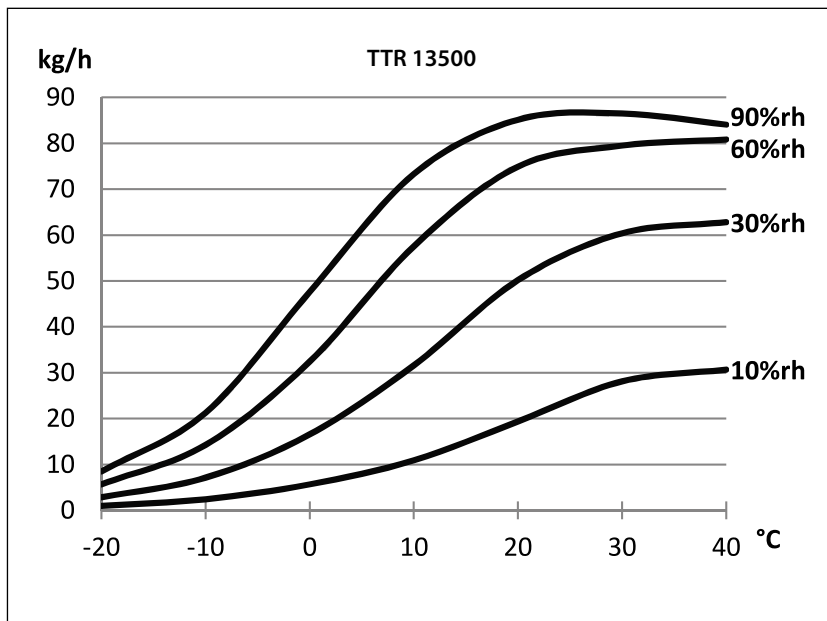

ADDITIONAL EQUIPMENT OPTIONS

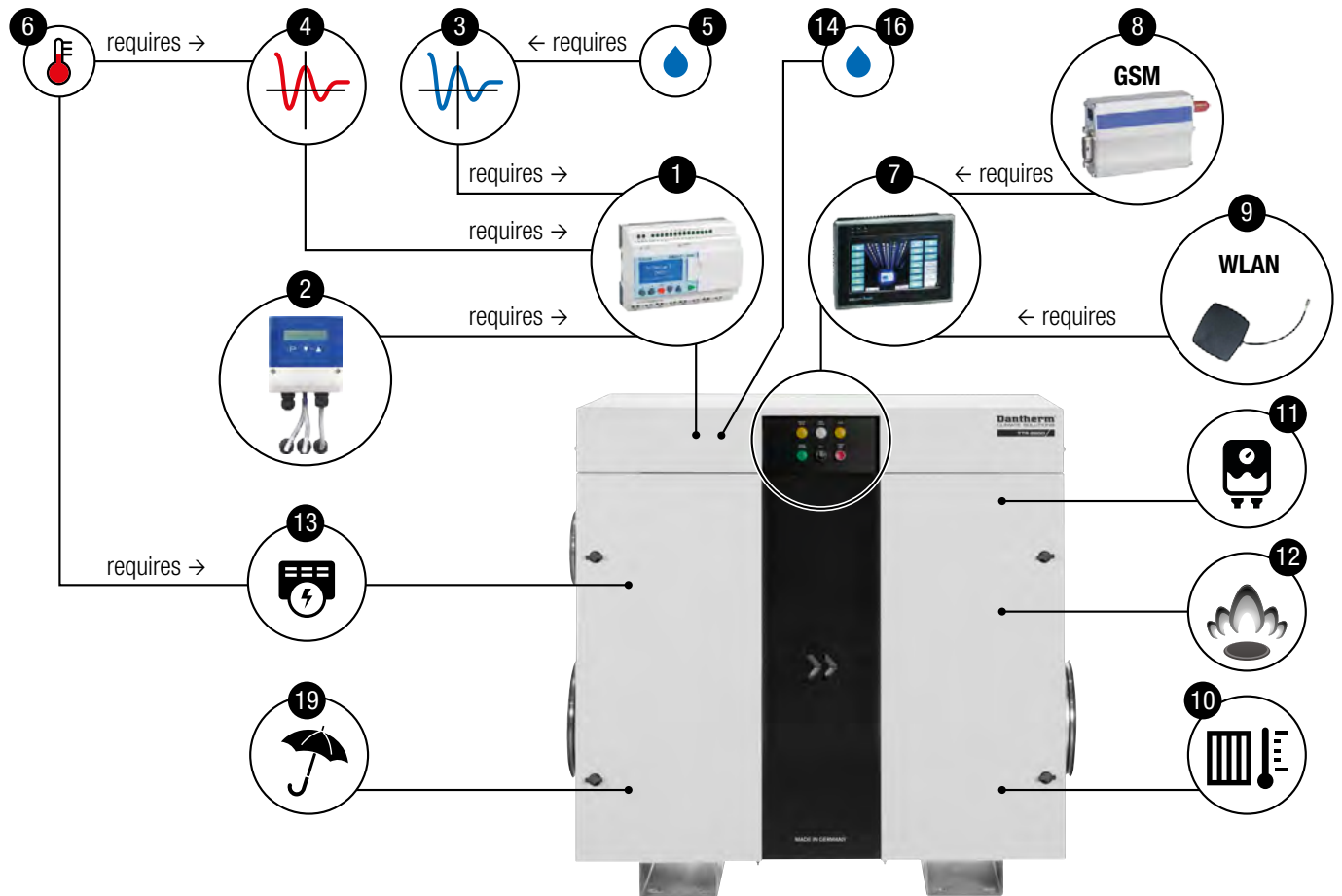

(See legend on the following pages)

ADDITIONAL EQUIPMENT OPTIONS

Additional equipment options (Article number)		TTR 800	TTR 1400	TTR 2000	TTR 2800	TTR 3700
1	PLC control module Millenium	6.100.010.401	6.100.010.401	6.100.010.401	6.100.010.401	6.100.010.401
2	Flowmatic S (requires 1)	6.100.010.405	6.100.010.405	6.100.010.405	6.100.010.405	6.100.010.405
3	Humidity control (requires 1)	6.100.010.415	6.100.010.415	6.100.010.415	6.100.010.415	6.100.010.415
4	Temperature control (requires 1)	6.100.010.416	6.100.010.416	6.100.010.416	6.100.010.416	6.100.010.416
5	Dew point sensor, -80°C ... +20°C (requires 3)	6.100.010.455	6.100.010.455	6.100.010.455	6.100.010.455	6.100.010.455
6	Pt100 temperature sensor (requires 1+4 and/ or 10 or 13)	6.100.010.460	6.100.010.460	6.100.010.461	6.100.010.461	6.100.010.461
7	Touchscreen for device operation (requires 1)	on request	on request	on request	on request	on request
8	GSM remote connection (requires 7)	on request	on request	on request	on request	on request
9	WLAN remote connection (requires 7)	on request	on request	on request	on request	on request
10	Integrated heat exchanger module stainless steel	–	–	6.100.010.437	6.100.010.437	6.100.010.437
11	Steam heater for regeneration air	–	–	6.100.010.440	6.100.010.440	6.100.010.440
12	Gas heater for regeneration air	–	–	6.100.010.445	6.100.010.445	6.100.010.445
13	Electric reheater for dry air	6.100.010.450	6.100.010.450	6.100.010.451	6.100.010.451	6.100.010.451
14	External hygrostat HG 120	6.100.002.040	6.100.002.040	6.100.002.040	6.100.002.040	6.100.002.040
15	4-pin connector coupling for HG 120	6.100.002.039	6.100.002.039	6.100.002.039	6.100.002.039	6.100.002.039
16	External thermohygrostat HG 125, electronic	6.100.002.042	6.100.002.042	6.100.002.042	6.100.002.042	6.100.002.042
17	7-pin connector coupling for HG 125	6.100.002.046	6.100.002.046	6.100.002.046	6.100.002.046	6.100.002.046
18	Wheels (4 swivel castors with brake)	6.100.010.510	6.100.010.510	6.100.010.511	6.100.010.511	6.100.010.511
19	Weather protection equipment	6.100.010.520	6.100.010.520	6.100.010.521	6.100.010.521	6.100.010.521
20	Protective and transport frame, stackable, without castors	–	–	–	–	–
21	Castors for transport frame	–	–	–	–	–
22	Transport frame, stackable, with castors	6.100.010.480	6.100.010.480	6.100.010.485	6.100.010.485	6.100.010.485
23	Filterbox (external) for HEPA air filtration	7.240.000.015	7.240.000.015	7.240.000.015	7.240.000.015	7.240.000.015
24	Hose adapter (2 x ø500mm)	–	–	–	–	–

ADDITIONAL EQUIPMENT OPTIONS

Additional equipment options (Article number)		TTR 5200	TTR 6600	TTR 8200	TTR 10000	TTR 12000	TTR 13500
1	PLC control module Millenium	■	■	■	■	■	■
2	Flowmatic S (requires 1)	■	■	■	■	■	■
3	Humidity control (requires 1)	6.100.010.415	6.100.010.415	6.100.010.415	6.100.010.415	6.100.010.415	6.100.010.415
4	Temperature control (requires 1)	6.100.010.416	6.100.010.416	6.100.010.416	6.100.010.416	6.100.010.416	6.100.010.416
5	Dew point sensor, -80°C ... +20°C (requires 3)	6.100.010.455	6.100.010.455	6.100.010.455	6.100.010.455	6.100.010.455	6.100.010.455
6	Pt100 temperature sensor (requires 1+4 and/or 10 or 13)	6.100.010.462	6.100.010.462	6.100.010.462	6.100.010.463	6.100.010.463	6.100.010.463
7	Touchscreen for device operation (requires 1)	on request	on request	on request	on request	on request	on request
8	GSM remote connection (requires 7)	on request	on request	on request	on request	on request	on request
9	WLAN remote connection (requires 7)	on request	on request	on request	on request	on request	on request
10	Integrated heat exchanger module stainless steel	6.100.010.438	6.100.010.438	6.100.010.438	6.100.010.439	6.100.010.439	6.100.010.439
11	Steam heater for regeneration air	6.100.010.441	6.100.010.441	6.100.010.441	6.100.010.442	6.100.010.442	6.100.010.442
12	Gas heater for regeneration air	6.100.010.445	6.100.010.445	6.100.010.445	6.100.010.445	6.100.010.445	6.100.010.445
13	Electric reheater for dry air	6.100.010.452	6.100.010.452	6.100.010.452	6.100.010.453	6.100.010.453	6.100.010.453
14	External hygrostat HG 120	6.100.002.040	6.100.002.040	6.100.002.040	6.100.002.040	6.100.002.040	6.100.002.040
15	4-pin connector coupling for HG 120	6.100.002.039	6.100.002.039	6.100.002.039	6.100.002.039	6.100.002.039	6.100.002.039
16	External thermohygrostat HG 125, electronic	6.100.002.042	6.100.002.042	6.100.002.042	6.100.002.042	6.100.002.042	6.100.002.042
17	7-pin connector coupling for HG 125	6.100.002.046	6.100.002.046	6.100.002.046	6.100.002.046	6.100.002.046	6.100.002.046
18	Wheels (4 swivel castors with brake)	6.100.010.512	6.100.010.512	6.100.010.512	6.100.010.513	6.100.010.513	6.100.010.513
19	Weather protection equipment	6.100.010.522	6.100.010.522	6.100.010.522	6.100.010.523	6.100.010.523	6.100.010.523
20	Protective and transport frame, stackable, without castors	6.100.010.490	6.100.010.490	6.100.010.490	6.100.010.495	6.100.010.495	6.100.010.495
21	Castors for transport frame	6.100.010.501	6.100.010.501	6.100.010.501	6.100.010.502	6.100.010.502	6.100.010.502
22	Transport frame, stackable, with castors	–	–	–	–	–	–
23	Filterbox (external) for HEPA air filtration	7.240.000.015	7.240.000.015	7.240.000.015	7.240.000.015	7.240.000.015	7.240.000.015
24	Hose adapter (2 x ø500mm)	–	–	–	6.100.010.524	6.100.010.524	6.100.010.524

■ standard equipment; □ optional equipment; further equipment available upon request, e.g. frost-protected version for outdoor installation, cold room insulation and much more

ADDITIONAL EQUIPMENT OPTIONS



Operation principles of the TTR desiccant dehumidifiers

Separate air flows of process and regeneration air implemented by one fan each. With purging sector for the heat recycling process for incoming regeneration air.

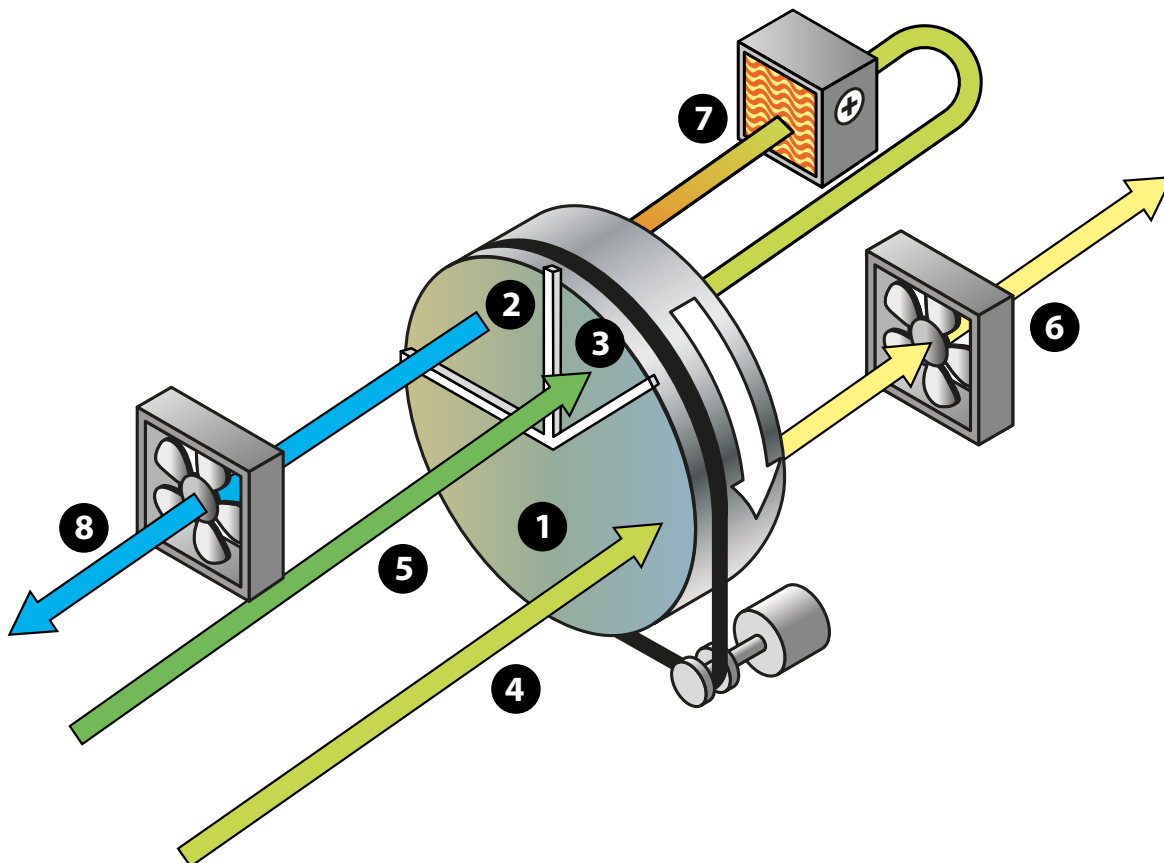

TTR-Trisorp-Dual 400 V
Legend for operation principles

- | | |
|---|---|
| <ul style="list-style-type: none"> 1. Dehumidification sector 2. Regeneration sector 3. Purging sector for heat recovery | <ul style="list-style-type: none"> 4. Process air 5. Regeneration air 6. Dry air 7. Heating 8. Wet air |
|---|---|



SD 400

A series of compact and efficient 4-hole desiccant dehumidifiers made of stainless steel (SS304) designed for moisture control in a wide range of applications.

This series of portable/removable desiccant dehumidifiers is suitable for use in small to medium-sized rooms or larger rooms with moderate dehumidification or moisture control needs.

- Enclosure in stainless steel (SS304) or acid-proof (SS316)
- Condenser (SD 400/500)
- Wall mount
- Floor stand (H:75 cm)
- Hour counter/Anmeter/Kilowatt timeteller
- Kilowatt-hour counter
- Hygrostat
- Electronic humidity control
- Dew point regulation
- Available with cooling/heating/humidification

This series can be used for dehumidifying air with up to 100% relative humidity (RH%) at temperatures ranging from -30°C to +60°C.

- Basements
- Small storage areas
- Garages
- Small waterworks
- Technical rooms
- Construction sites
- Museums, galleries, and archives
- Equipment preservation
- Material transport and logistics

Target sketch

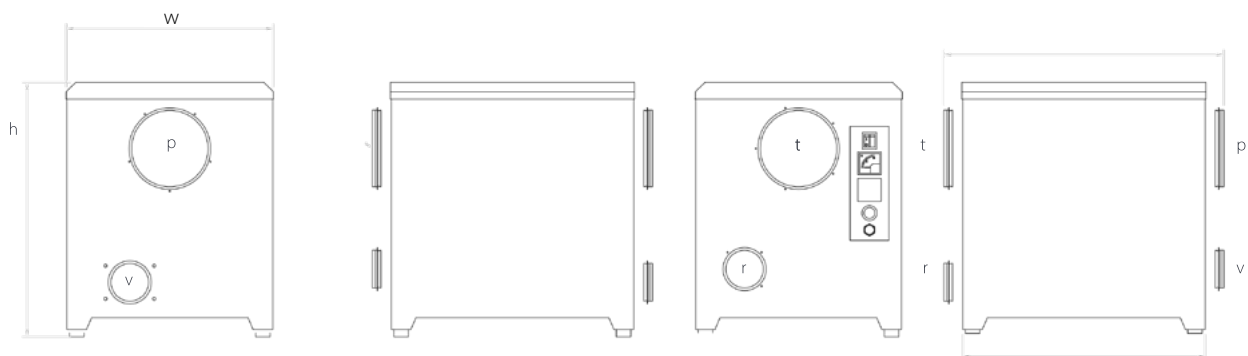

Capacity diagram

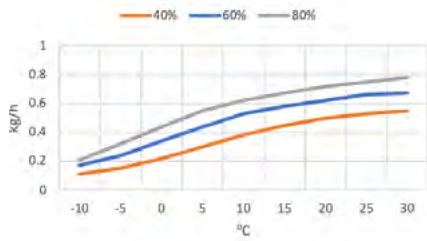

SD 210

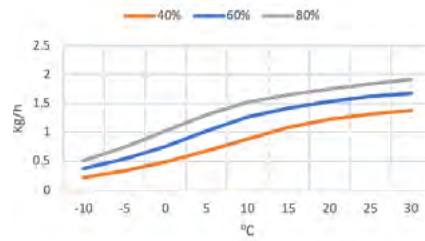

SD 400

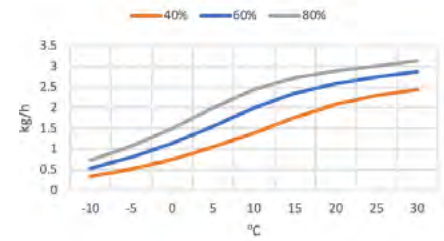

SD 500

Specifications	Units	SD 210	SD 400	SD 500
Process air	m ³ /h	210	400	500
Reg air	m ³ /h	40	30	120
Capacity (20°C/60% RH)	kg/h	0.6	1.4	2.6
Voltage	V	1 x 230	1 x 230	1 x 230
Effect	kW	1.1	2.3	3.5
Effect reg	kW	0.8	2	3.2
Audio	dB	53	62.2	63
Weight	kg	16.5	22	31
Dimensions (l x w x h) without support/handle	mm	335 x 357 x 351	500 x 428 x 526	500 x 428 x 526
Target (t - dry air)	Ømm	100	160	160
Target (p - process air)	Ømm	125	160	160
Target (v - wet air)	Ømm	80	80	80
Target (r - regeneration air)	Ømm	80	80	80
Steering		HYG	HYG	HYG
C-model/condenser*		NO	YES	YES

*Available as C model - with condenser

SD 800-1100



SD 800

A mid-sized desiccant dehumidifier designed for commercial and industrial applications. Desiccant dehumidifiers have several features that can be customised to specific requirements. Low energy consumption combined with flexible control makes these dehumidifiers ideal for continuous process applications and where good climate control is a requirement. The stainless steel construction also allows this range to be used where hygiene is an important requirement.

- Enclosure in stainless steel (SS304) or acid-proof (SS316)
- Optional insulated double-skinned enclosure
- PLS
- EC fans with speed control
- Filter guard and rotor guard
- Hour meter/Ampere meter/Kilowatt hour meter
- Hygrostat
- Electronic moisture management
- Available with condenser

Target sketch

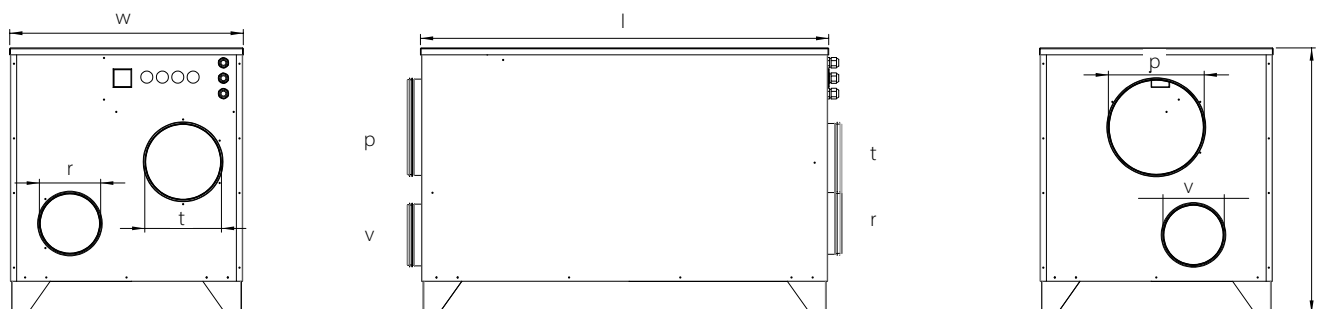

Fixed installation suitable is for some larger installations. Equipped with a condenser (SD-C), it is well suited for applications where wet air cannot be led out of the building.

- Waterworks
- Mountain facilities
- Defence
- Food industry
- Laboratories and cleanrooms
- Museums, galleries and major archives
- Pharmaceutical
- Construction processes and building preservation
- Ships

SD 800-1100

Capacity diagram

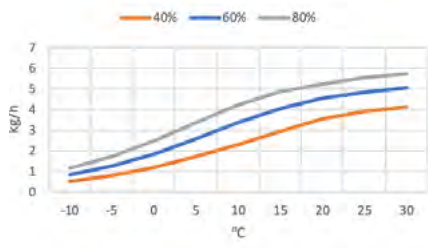

SD 800

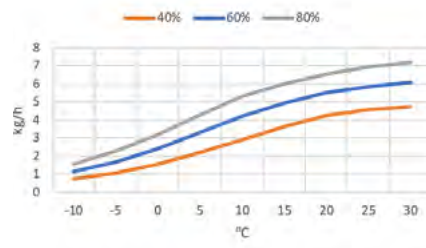

SD 1100

Specifications	Units	SD 800	SD 1100
Process air (EC)	m ³ /h	800	1,100
Reg air (EC)	m ³ /h	250	370
Capacity (20°C/60% RH)	kg/h	4.4	6
Voltage*	V	3 x 400	3 x 400
Effect	kW	7	10
Effect reg	kW	6.7	9.25
Audio	dB	60	62
Weight	kg	80	80
Dimensions (l x w x h) without support/handle	mm	1061 x 607 x 689	1061 x 607 x 689
Target (t - dry air)	Ømm	200	200
Target (p - process air)	Ømm	250	250
Target (v - wet air)	Ømm	160	160
Target (r - regeneration air)	Ømm	160	160
Steering**		HYG	HYG
SD communication		ON REQUEST	ON REQUEST
*Can be supplied with 3 x 230			
**Can be supplied with PLS			
C-model/condenser*		YES	YES

*Available as C model - with condenser



SD 2300

A range of four compact, high-capacity desiccant dehumidifiers with great flexibility in air flow rates with an insulated corrosion-resistant cabinet and advanced PLC controls suitable for both commercial and industrial applications. Designed to operate in both standard and customised modes, this range of desiccant dehumidifiers is a versatile option for a variety of applications. Energy efficiency and control options make these dehumidifiers ideal for continuous process applications and where full control is required. The stainless steel construction also allows this range to be used where hygiene is an important requirement and where cooling or lower process temperatures are required.

- Insulated double-skinned enclosure
- Powder-coated, alternative stainless/acid-resistant (SS304 or SS316)
- PLS EC fans with speed control
- Filter Guard and Rotor Guard
- SD communication (Modbus/BACnet)
- Heat exchanger for regeneration air
- Available with cooling/heating/humidification
- Available with condenser



This range can be used for dehumidification of air with up to 100% relative humidity (RH%) with temperatures from -30°C to +60°C.

- Waterworks
- Mountain facilities
- Defence
- Buildings and construction
- Food industry
- Laboratories and cleanrooms
- Industrial processes
- Material transport and logistics

Target sketch

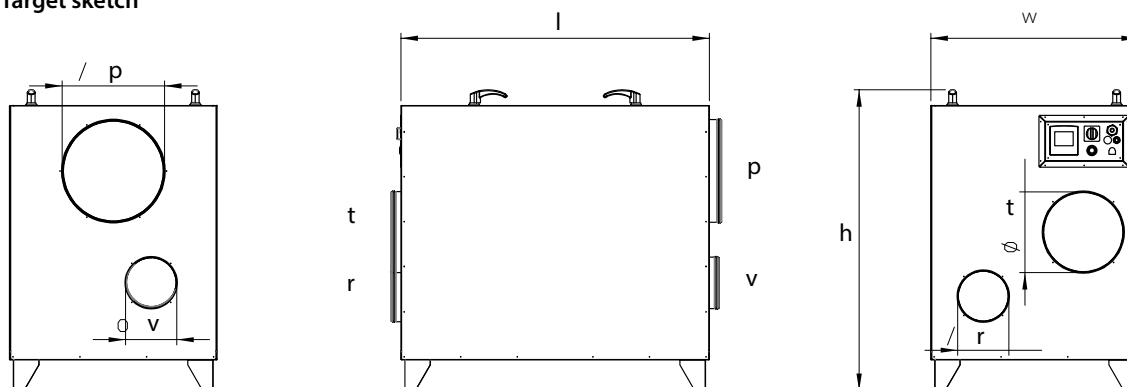

Capacity diagram

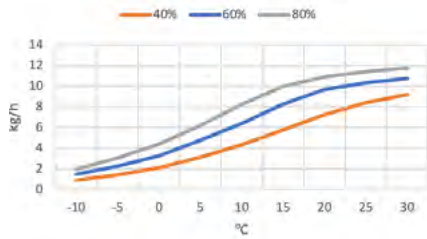

SD 1300

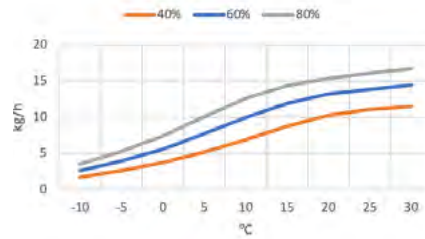

SD 2300

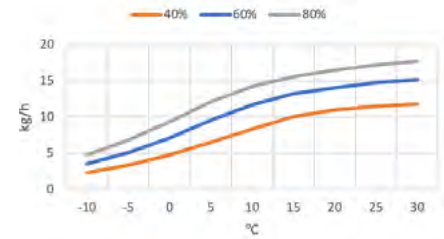

SD 3300

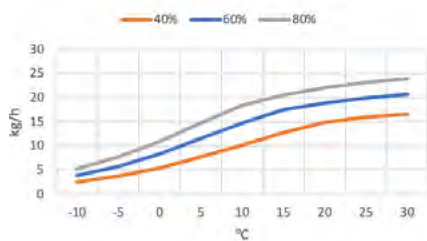

SD 3500

Specifications	Units	SD 1300	SD 2300	SD 3300	SD 3500
Process air (EC)	m ³ /h	1,300	2,300	3,300	3,500
Reg air (EC)	m ³ /h	400	500	550	900
Capacity(20°C/60% RH)	kg/h	9.5	13.8	14.7	17.7
Voltage*	V	3 x 400	3 x 400	3 x 400	3 x 400
Effect	kW	13.6	19	20.6	27
Effect reg	kW	13	17.5	18	24.4
Audio	dB	63	71	70.4	71
Weight	kg	200	200	205	350
Dimensions (l x w x h) without support/handle	mm	1199 x 807 x 1170	1199 x 807 x 1170	1199 x 807 x 1170	1199 x 807 x 1170
Target (t - dry air)	Ømm	315	315	315	315
Target (p - process air)	Ømm	400	400	400	400
Target (v - wet air)	Ømm	200	200	200	200
Target (r - regeneration air)	Ømm	200	200	200	200
Steering		PLS	PLS	PLS	PLS
SD communication**		Modbus TCP/IP	Modbus TCP/IP	Modbus TCP/IP	Modbus TCP/IP
*Can be supplied with 3 x 230					
**BacNet as an option					
Max*		YES	YES	YES	YES
C-model/condenser**		YES	YES	YES	NO

*Can be supplied as Max - climate control

**Available as C model - with condenser

Industrial desiccant dehumidifiers
SD 4500-5800-7000-9000



SD 9000

A range of four powerful desiccant dehumidifiers with a wide range of air flow rates with insulated cabinets and pre- and post-treatment options suitable for both commercial and industrial applications. They have several features that can be tailored to specific requirements, including pre- and post-treatment, energy efficiency and demanding control requirements

- Insulated double-skinned enclosure
- Powder-coated, alternative stainless/acid-resistant (SS304 or SS316)
- PLS
- EC fans with speed control
- Filter guard and rotor guard
- SD communication (Modbus/BACnet)
- Heat exchanger for regeneration air
- Available with cooling/heating/humidification



This series can be used to dehumidify air with up to 100% relative humidity (RH%) with temperatures from -30°C to +60°C.

- Food industry
- Aquaculture (indoor fish farming, slaughterhouses, etc.)
- Agriculture
- Pharmaceutical
- Defence
- Buildings and construction
- Larger waterworks
- Industrial processes
- Material transport and logistics
- Laboratories, cleanrooms and research facilities
- Ice rinks

Target sketch

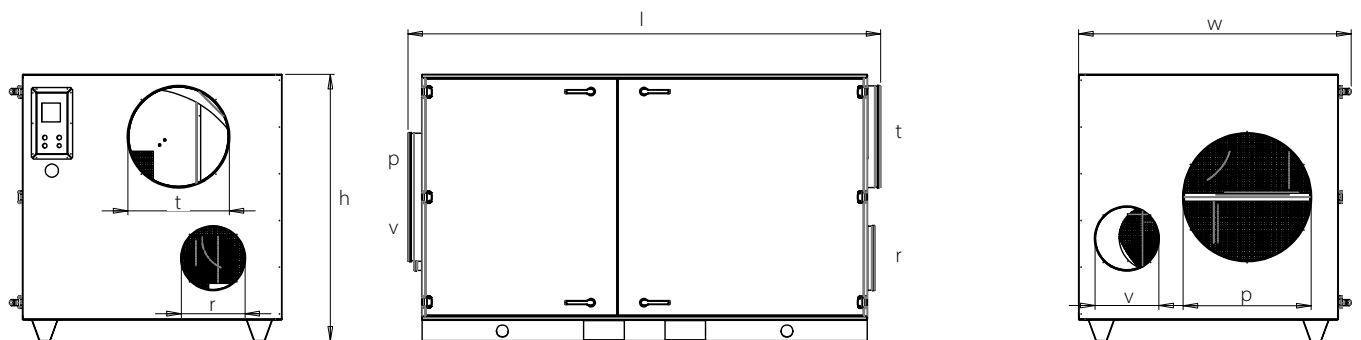

Capacity diagram

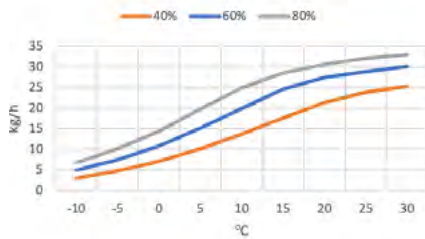

SD 4500

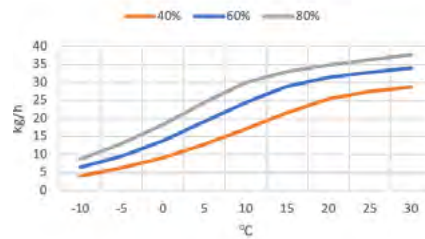

SD 5800

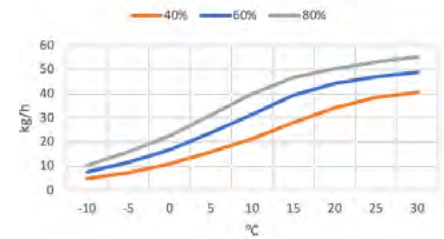

SD 7000

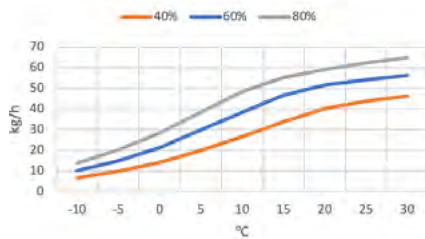

SD 9000

Specifications	Units	SD 4500	SD 5800	SD 7000	SD 9000
Process air (EC)	m ³ /h	4,500	5,800	7,000	9,000
Reg air (EC)	m ³ /h	1,500	1,400	2,200	2,500
Capacity(20°C/60% RH)	kg/h	24.6	29.3	43	50
Voltage	V	3 x 400	3 x 400	3 x 400	3 x 400
Effect	kW	40.8	44.8	65.5	80
Effect reg	kW	36	44	60	72
Audio	dB	72	72	72	72
Weight	kg	410	520	540	550
Dimensions (l x w x h) without support/handle	mm	2193 x 1277 x 1311	2193 x 1277 x 1311	2193 x 1277 x 1311	2193 x 1277 x 1311
Target (t - dry air)	Ømm	500	500	500	500
Target (p - process air)	Ømm	630	630	630	630
Target (v - wet air)	Ømm	315	315	315	315
Target (r - regeneration air)	Ømm	315	315	315	315
Steering		PLS	PLS	PLS	PLS
SD communication**		Modbus TCP/IP	Modbus TCP/IP	Modbus TCP/IP	Modbus TCP/IP
*BacNet as an option					
Max*		YES	YES	YES	YES

*Can be supplied as Max - climate control



SD 6000

A range of large, powerful desiccant dehumidifiers with a wide range of air flow rates with insulated casing built up from solid frame profiles with pre- and post-treatment options suitable for both commercial and industrial applications. They have several features that can be customised to specific requirements, including pre- and post-treatment, energy efficiency and demanding control requirements

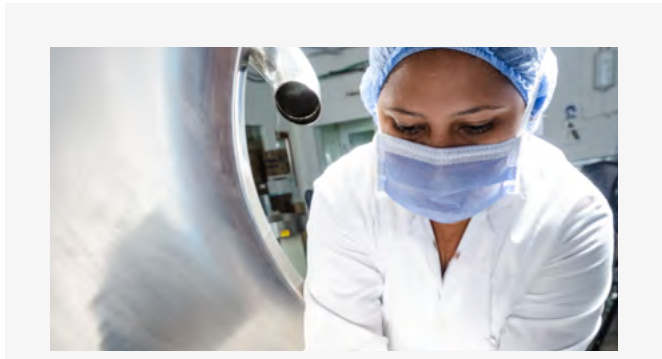

This range can be used for dehumidification of air with up to 100% relative humidity (RH%) with temperatures from -30°C to +60°C.

- Food industry
- Aquaculture
- Agriculture
- Buildings and construction
- Industrial processes
- Material transport and logistics
- Cold storage and warehouses
- Ice rinks

- Insulated double-skinned enclosure
- Powder-coated, alternatively stainless/acid-resistant (SS304 or SS316)
- PLS
- EC fans with speed control
- Filter guard and rotor guard
- SD communication (Modbus/BACnet)
- Heat exchanger for regeneration air
- Purge function for reduced energy consumption

Target sketch

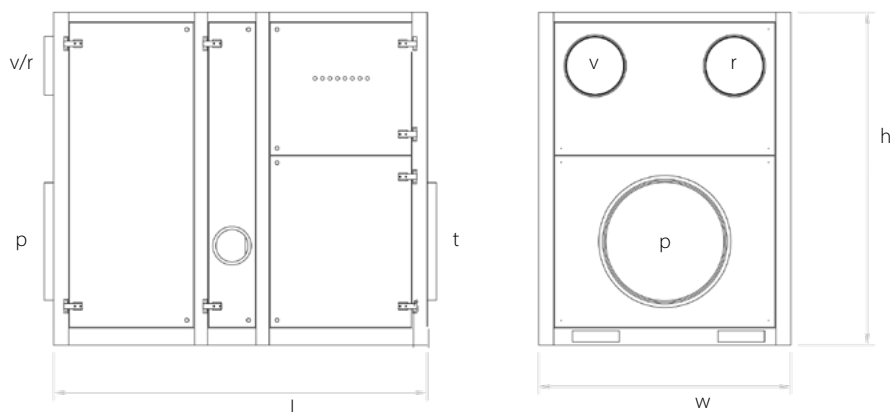

Capacity diagram

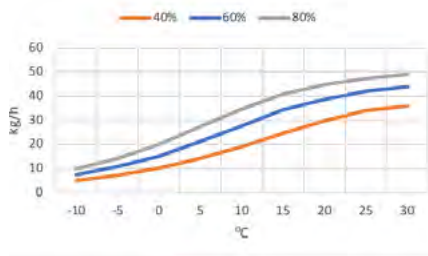

SD 6000

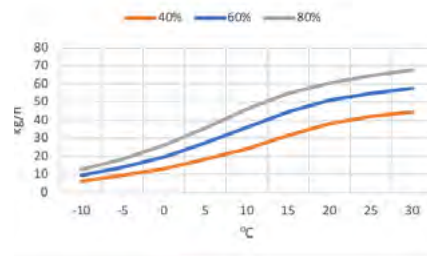

SD 8000

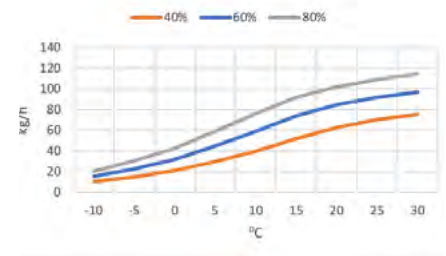

SD 13000

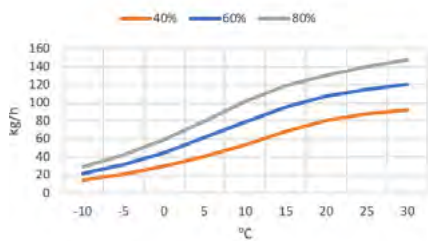

SD 19000

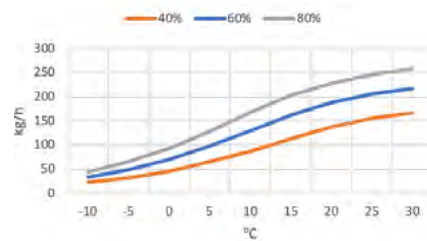

SD 27000

Specifications	Units	SD 6000	SD 8000	SD 13000	SD 19000	SD 27000
Process air (EC)	m ³ /h	6,000	8,000	13,000	19,000	27,900
Reg air (EC)	m ³ /h	1,700	2,500	4,200	6,000	6,980
Capacity(20°C/60% RH)	kg/h	39	53	86	126	182
Voltage	V	3 x 400	3 x 400	3 x 400	3 x 400	3 x 400
Effect	kW/amp	54.2	80.5	143.5	207.5	309
Effect reg	kW	48	72	132	192	288
Weight	kg	900	950	1350	1700	2400
Dimensions (l x w x h) without support/handle	mm	2000 x 1350 x 1780	2000 x 1350 x 2050	2250 x 1600 x 2300	2400 x 1900 x 2500	2900 x 2400 x 2500
Target (t - dry air)	Ømm	630	630	800	1000	1000
Target (p - process air)	Ømm	630	630	800	1000	1000
Target (v - wet air)	Ømm	315	315	500	630	630
Target (r - regeneration air)	Ømm	315	315	500	630	630
Steering		PLS	PLS	PLS	PLS	PLS
SD communication*		Modbus TCP/IP	Modbus TCP/IP	Modbus TCP/IP	Modbus TCP/IP	Modbus TCP/IP
*BacNet as an option						
Max*		YES	YES	NO	NO	NO

*Can be supplied as Max - climate control



SD 55000

The series of the very largest desiccant dehumidifiers are built in sections and can be delivered in modules to the installation site. The powerful desiccant dehumidifiers with a wide range of air volumes have an insulated casing built up from solid frame profiles and with pre- and post-treatment options suitable for both commercial and industrial applications. They have several features that can be customised to specific requirements, including pre- and post-treatment, energy efficiency and demanding control requirements.

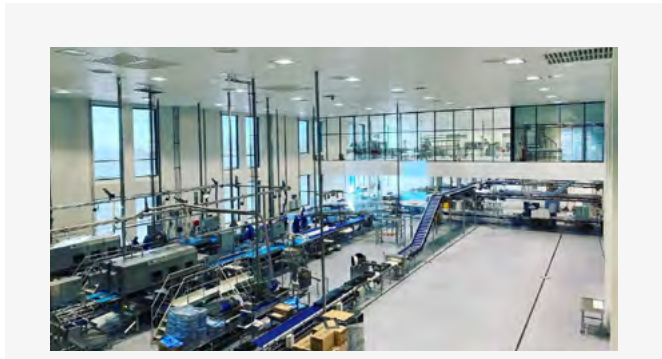

This range can be used for dehumidification of air with up to 100% relative humidity (RH%) with temperatures from -30°C to +60°C.

- Food industry
- Aquaculture
- Agriculture
- Buildings and construction
- Industrial processes
- Material transport and logistics
- Cold storage and warehouses
- Ice rinks

Specifications	Units	SD 35000	SD 40000	SD 45000	SD 55000
Process air (EC)	m ³ /h				ON REQUEST
Reg air (EC)	m ³ /h				ON REQUEST
Capacity(20°C/60% RH)	kg/h				ON REQUEST
Voltage	V				ON REQUEST
Effect	kW/amp				ON REQUEST
Effect reg	kW				ON REQUEST
Weight	kg				ON REQUEST
Dimensions (l x w x h) without support/handle	mm				ON REQUEST
Steering					ON REQUEST
SD					ON REQUEST
Max*					ON REQUEST

SD MAX SERIES

As an option on: SD 1300 | SD 2300 | SD 3300 | SD 3500 | SD 4500
| SD 5800 | SD 6000 | SD 7000 | SD 8000 | SD 9000 and on all the
larger customised systems



SD MAX - SERIES

The Dantherm SD MAX series is based on SD desiccant dehumidifiers. SD Max is a flexible and compact climate system that gives you an optimal indoor climate and full control over temperature and humidity.

The SD MAX system is based on:

- **Dehumidification** with a high-absorption capacity desiccant rotor. Energy recovery sector for high performance. Certified bacteriostatic desiccant rotor

In addition, one or more of:

- **Humidification:** Steam distributor or evaporation (evaporative)
- **Cooling:** Ice water or DX
- **Heating:** Hot water or electric

Features and benefits

- Create a healthier climate
- Constant climate with minimal deviations
- Flexible system with ready-made modules that can be combined according to customer needs
- Stepless regulation for minimised energy consumption
- Keep humidity low in storage applications
- Reduce humidity during industrial processes
- Keeps temperature-sensitive products dry
- Monitors humidity in museums and archives
- Maintains humidity at the desired RH% when the outdoor temperature drops and dry air is supplied to the premises (humidity is added)
- Modular solution, easy installation

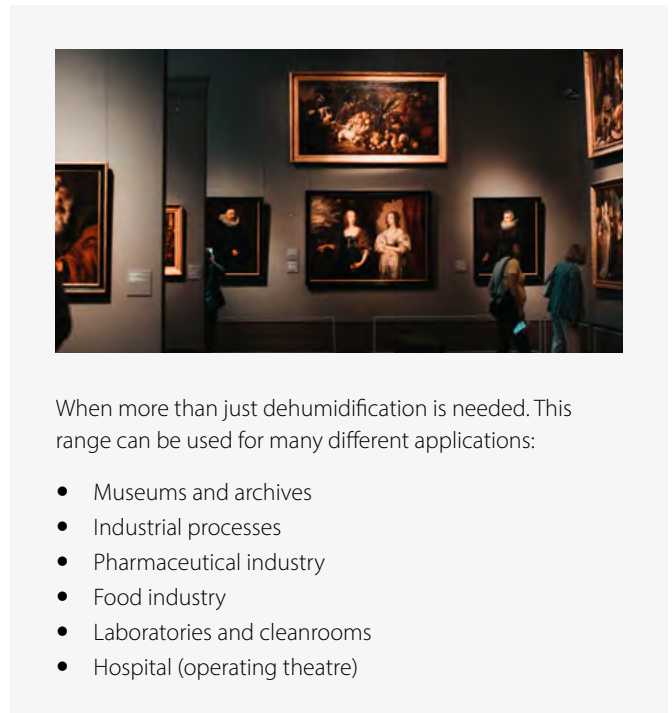

When more than just dehumidification is needed. This range can be used for many different applications:

- Museums and archives
- Industrial processes
- Pharmaceutical industry
- Food industry
- Laboratories and cleanrooms
- Hospital (operating theatre)

Heating coil for the regeneration air

PTC (Positive Temperature Control) type heating coil, which cannot overheat. It allows for stepless capacity regulation in the range of 50-100% of the dehumidification capacity. This is simply done by regulating the wet air flow.

SD MAX systems are delivered as complete systems with product and function warranty (start-up is always included in the delivery).

SD 400 MINI MAX



SD 400 MINI MAX

Plug and play

Dantherm SD 400 MINI MAX is a compact standard unit with a dehumidifier, humidifier, heating and cooling for climate control in museums and archives. Equipped with plug, ready for connection to ice water/DX, mains water (humidification), ducts and drainage.

SD 400 MINI MAX has the following features:

- **Dehumidification** with a high-absorption capacity desiccant rotor. Energy recovery sector for high performance. Certified bacteriostatic desiccant rotor
- **Humidification:** Steam distributor or evaporation (evaporative)
- **Cooling:** Connected to DX (possibly ice water)
- **Heating:** Electric



Well suited for museums and archive rooms up to approx. 50m².

- Constant climate with minimal deviations.
- Automatically adjusts to the desired humidity and temperature
- Maintains the desired humidity (RH%) when the outdoor temperature drops and dry fresh air is supplied to the premises
- Stepless regulation for minimal energy consumption
- Compact design that's easy to position
- Full functional responsibility with one supplier

Specifications	Units	SD 400 MINI MAX
Dry air	m ³ /h	390
Wet air	m ³ /h	100
Dehumidification capacity	kg/h	1.3
Total effect	kW	2
Voltage with plug	V	1 x 230
Weight	kg	25
Dimensions (l x w x h) without support/handle	mm	670 x 373.5 x 356.5



SD C - SERIES

The Dantherm SD C series is based on SD desiccant dehumidifiers. The SD C series also includes a condenser, which converts the moist waste air (wet air) into water. The water can be collected in a container or drained to a drain. The SD C series is ideal from 2°C to 12°C but can be used in warmer environments



Where you want to avoid leading the wet/regeneration air out of the building/system via ducts.

Well suited at lower temperatures and when the distance to the exhaust is large.

- Mountain halls
- Tunnels
- Waterworks
- Older or listed buildings where you want to avoid the use of ducts
- Defence

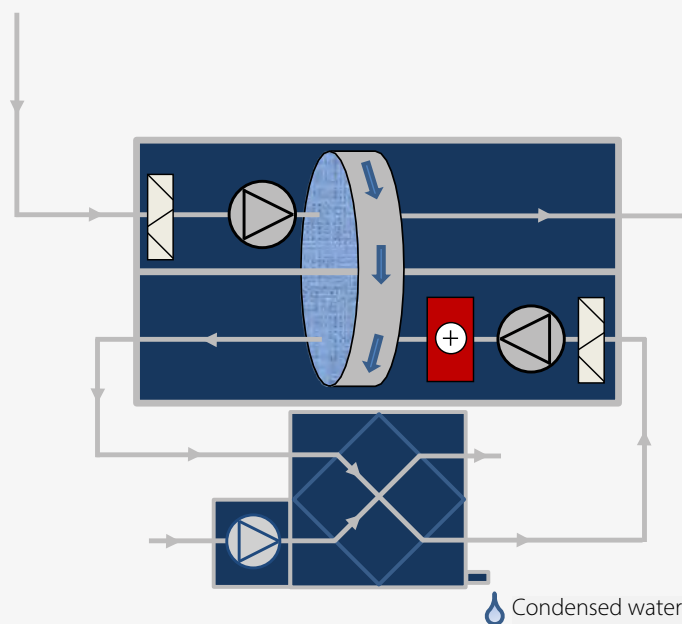

SD 1500-2600-3600-4000 ICE



SD 2600 ICE

Dantherm SD ICE is a range of dehumidifiers specially designed to dehumidify the air in cold stores.

There are two versions. For installation:

- Inside the freezer compartment, a 30mm fully insulated cabinet
- The outside freezer compartment has a 100mm fully insulated enclosure to minimise the risk of condensation/icing and can also be equipped with an air-to-air heat exchanger to further reduce energy consumption

Both versions are energy-optimised for normal freezer room air conditions. For example, the energy consumption of the SD 3600 ICE freezer version is 55% lower than comparable products on the market.



Well suited for museums and archive rooms up to approx. 50m².

- Constant climate with minimal deviations.
- Automatically adjusts to the desired humidity and temperature
- Maintains the desired humidity (RH%) when the outdoor temperature drops and dry fresh air is supplied to the premises
- Stepless regulation for minimal energy consumption
- Compact design that's easy to position
- Full functional responsibility with one supplier

Dehumidifier principle for freezer room with heat exchanger

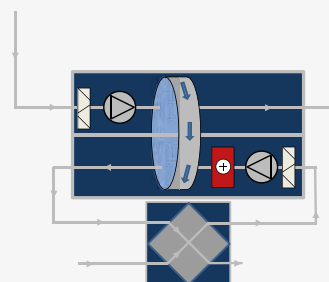

Specifications	Units	SD 1500 ICE	SD 2600 IC	SD 3600 ICE	SD 4000 ICE
Dry air	m ³ /h	1,500	2,600	3,600	4,000
Wet air	m ³ /h	220	300	350	600
Capacity (-18°C/60% RH)	kg/h	1.25	2.12	2.94	3.21
Voltage	V	3 x 400	3 x 400	3 x 400	3 x 400
Total effect	kW	6.1	10.5	11.9	18.8
Dimensions (l x w x h) for internal installation	mm	1199 x 807 x 1170	1199 x 807 x 1170	1199 x 807 x 1170	1199 x 807 x 1170
Dimensions (l x w x h) for external installation	mm	1339 x 947 x 1245	1262 x 947 x 1245	1262 x 947 x 1245	1262 x 947 x 1245

**SD 60000 SK**

Dantherm supplies air conditioning systems with desiccant cooling up to 60,000m³/h.

The desiccant cooling systems ensure a comfortable air temperature in summer. In winter, they also help with moisture recovery so that it doesn't get too dry in sensitive environments.

- Fully insulated (50mm) enclosure and panels in Galvanised metal
- Specially designed drive gear for the desiccant rotor that optimises the dehumidification process in summer
- Direct drive EC-regulated chamber fans with low noise and low SFP
- Evaporative (evaporative) humidifiers with direct water systems or circulating water systems for reduced water consumption
- Available with or without control and regulation equipment



Application areas

Larger facilities that require energy-efficient cooling and ventilation.

The process explained

The process is based on the laws of physics. For every gram of water added to one kg of air, the temperature drops by 2.5°C.

First, the hot outdoor air is dehumidified in the desiccant rotor. The dry and warm air from the desiccant rotor is then cooled in the rotary heat exchanger and then cooled and humidified using the evaporative humidifier in the supply air. The result is cool supply air with a slightly lower water content than incoming outdoor air.

Specifications	Units	SD 9000 SK	SD 13000 SK	SD 19000 SK	SD 22000 SK	SD 30000 SK	SD 40000 SK	SD 60000 SK
Air volume	m ³ /h	9,000	13,000	19,000	22,000	30,000	40,000	60,000
Cooling capacity	kW	36	52	76	88	120	160	240
Motor power supply air	kW	4	5.5	7.5	11	15	18.5	30
Motor power extraction	kW	4	7.5	11	11	15	22	30
Voltage	V	3 x 400	3 x 400	3 x 400	3 x 400	3 x 400	3 x 400	3 x 400
Dimensions (l x w x h)	mm	5100 x 1950 x 2100	5100 x 2250 x 2390	5800 x 2550 x 2690	5800 x 2800 x 2940	7810 x 3150 x 3580	7810 x 3600 x 3880	7810 x 4350 x 4390

3-HOLES VERSUS 4-HOLES DEHUMIDIFIERS

3-holes

The dehumidifier works using two air streams: the air stream to be dehumidified and the air stream to dry the rotor. A fan inside the dehumidifier creates these two air streams that cross the rotor in opposite directions. In a three-hole dehumidifier, the regeneration air is taken from the room (together with process air) and will create negative pressure in the room in which it is located. This can increase the moisture load in the room.

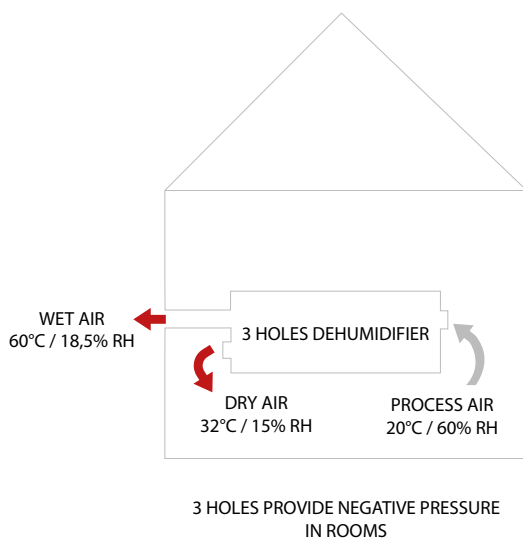

4-holes

The dehumidifier works using two air streams: the air stream to be dehumidified and the air stream to dry the rotor. Two fans inside the dehumidifier create these two air streams that cross the rotor in opposite directions. With a four-hole dehumidifier, the air streams are kept separate which maintains balanced air conditions in the room.

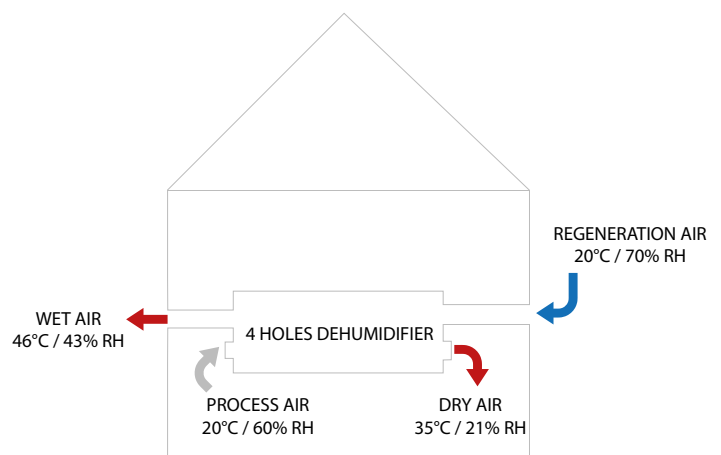

Desiccant dehumidifier

PLS CONTROLLER

A programmable logic controller (PLC) (in English: Programmable Logic Controller - PLC)

A PLC controller is often used on larger models or where there is a requirement for more advanced control and more functions. A PLC is also used when there is a requirement to output different data on, for example, an SD system (central operating system).

There are also several types of communication protocols to choose from:

- Modbus RS232
- Modbus RS485
- Modbus TCP/IP
- BacNet

The PLC controller is equipped with a 4" integrated 16-bit touchscreen and is IP66-rated

Unit name	SD 210	SD 400	SD 500	SD 800	SD 1100	SD 1300	SD 2300	SD 3300	SD 3500	SD 4500	SD 5800	SD 6000	SD 7000	SD 8000	SD 9000	Larger models ¹	
Product property																	
	3-hole or 4-hole dehumidifier	4	4	4	4	4	4	4	4	4	4	4	4	4	4	4	
MAX - SERIES	Available with cooling/heating/humidification			*	*	*	*	*	*	*	*	*	*	*	*	*	
C - SERIES	Available with condenser		*	*	*	*	*	*	*								
CABINET	Insulated double-skinned enclosure				*	*	S	S	S	S	S	S	S	S	S	S	
	Powder-coated cabinet						S	S	S	S	S	S	S	S	S	S	
	Enclosure in stainless steel (SS304)	S	S	S	S	S	*	*	*	*	*	*	*	*	*	*	
	Enclosure in acid-proof (SS316)	*	*	*	*	*	*	*	*	*	*	*	*	*	*	*	
	Epoxy lacquered interior						*	*	*	*	*	*	*	*	*		
	Handles																
	Wall mount	*	*	*													
	Floor stand (H:75cm)	*	*	*													
	Access from the side						*	*	*	*	S	S	S	S	S	S	S
	Wall mount		*	*													
	Cover plate for process air Ø125mm																
	Cover plate for process air 2X Ø80mm																
	Cover plate for process air Ø125mm																
Product setup/options																	
TARGETS	Hour counter	S	S	S	*	*											
	Ammeter	*	*	*	*	*											
	Kilowatt-hour meter	*	*	*	*	*											
FUEL SENSORS	Hygrostat HR1 - external or integrated	*	*	*	*	*						*		*			
	Connector plug for HR1 hygrostat (male + female)	*	*	*													
	Duct hygrostat HMH - external or integrated	*	*	*	*	*						*		*			
	Moisture sensors for DCS (1: integrated, 2: room and 3: duct)				*	*	*	*	*	*	*	*	*	*	*	*	
	Wet air thermostat (integrated)				*	*	*	*	*	*	*	*	*	*	*	*	
FLUID CONTROL	Electronic moisture control KC2 - integrated or separate	*	*	*	*	*						*		*			
	Dew point control KC4 (not installed, supplied separately)	*	*	*	*	*						*		*			
	Dew point control KC4 (integrated)	*	*	*	*	*						*		*			
STEERING	PLS 35				*	*	S	S	S	S		*		*			
	PLS 45										S	S	S	S	S	S	
	Modbus TCP/IP card for DCS				*	*	*	*	*	*	*	*	*	*	*	*	
	Modbus RTU RS485 card for DCS				*	*	*	*	*	*	*	*	*	*	*	*	
	Modbus card for KC4	*	*	*	*	*						*		*			
	Modulating heating control - for external 0-10V signal (only with PLC)						*	*	*	S	*	*	*	*	*	*	
ALARM	Filter guard				*	*	*	*	*	*	*	*	*	*	*	*	
	Rotor guard				*	*	S	S	S	S	S	S	S	S	S	S	
WRESTLER	External main switch (125A)											*		*			
FANS	EC process air fan	S	S	*	S	*	S	S	S	S	S		S		S		
	EC reactivation fan				S	S	*	*	*	S	S	S		S		S	
	EC wet air fan	S	S									*		*		*	
	EC dry air fan											*		*		*	
	Speed control for EC process fan	*	*	*	*	*	*	*	*	*	*	*	*	*	*	*	
C - SERIES	Air-cooled condenser small	*	*														
	Air-cooled condenser large				*	*	*	*									
	Air-cooled condenser with extra corrosion protection	*	*	*	*	*	*	*									
HEAT EXCHANGER	Wet air heat exchanger				*	*	*	*	*	*	*	*	*	*	*	*	









¹Larger models from SD 13000 and up

DRYING ACCESSORIES









DHP 33-55-77 | DHP 33-55-77 TTW**Optional accessories**



Each unit comes with a wall-mounting installation bracket ready for easy installation of the new dehumidifier.
For added configuration of a given dehumidifier, please see the table below.

Illustration	Accessory	Description	Code
	Remote controller, DRC	Wireless remote controller for simple monitoring of room conditions and/or adjustability of setpoints. Frequency: 868MHz Range: up to 50m (depending on signal blockage from wall material, etc.) Reading and adjusting RH, temperature, alarms, and service information	112450
	External RH/T sensor	Remote combi sensor for relative humidity and temperature with a 10m wired connection.	051710
	Floor mounting kit, 2 pcs.	Two brackets for installation under the dehumidifier for floor mounting purposes. Colour: RAL 7010	30102148
	Water heating coil	Compact water heating coil for easy mounting on top of the condenser. The kit comprises of the water heater, flexible hoses, fittings, gaskets, and a relay. Capacities*: • 2.6 kW • 4.2 kW • 6.2 kW (*depending on dehumidifier size and in-/outlet temperatures. Here 80/60°C)	094333 094334 094335
	DN 10 control valve and actuator for water heating coils	Valve and 230 V actuator and for ON/OFF, with unit nuts Ø12mm	094340
	Through-wall duct kit	Through-wall duct kit with filter, extension kit and aluminium grill. Comprises inlet and outlet section, grills, inlet filter and extension. For walls between 70 and 366mm thickness.	094243
	Electrical heating coils	Resistance heaters including relays and wires. Capacities*: • 2.0 kW • 3.5 kW • 5.0 kW (*depending on unit size)	094336 094337 094338
	Exhaust fan, low air flow	The exhaust fan can be used in combination with the DHC to either increase dehumidification capacity and/or ensuring negative pressure between the out- and inside. Low air flow: Power supply: 230 V/50 Hz Power consumption: 7.5W Air volume: 97m ³ /h Sound level: 25dB(A) Diameter: 100mm	094339
	Exhaust fan, high air flow	High air flow: Power supply: 230 V/50 Hz Power consumption: 17W Air volume: 185m ³ /h Sound level: 32dB(A) Diameter: 125mm	094341

CDP 40-50-70 | CDP 40T-50T-70T

Illustration	Accessory	Description	Products	Code
	Remote control, DRC1	<p>DRC1 is a wireless RH and temperature controller. Frequency: 868 mhz</p> <p>Range: Up to 50m depending on the conditions Protection class: IP20</p> <p>Functionalities:</p> <ul style="list-style-type: none"> • Reading and setting of RH, temperature, alarms and service information • Locking of settings 	<p>CDP 40 CDP 50 CDP 70 CDP 40T CDP 50T CDP 70T</p>	112450
	External RH/t sensor	<p>Remote sensor with 10 meter wire Protection class: IPX7</p>	<p>CDP 40 CDP 50 CDP 70 CDP 40T CDP 50T CDP 70T</p>	051710
	Floor mounting kit, 2 pcs	Each bracket to be mounted on each side of the dehumidifier	<p>CDP 40 CDP 50 CDP 70</p>	094322
	<p>Water heating coil 2.6 kW* Water heating coil 4.2 kW* Water heating coil 6.2 kW*</p>	<p>Comprises water heating coil, flexible hose, fittings and gasket</p> <p>*at 80/60° C</p> <p><i>(See technical specifications for water heating coils on separate page).</i></p>	<p>CDP 40, 40T CDP 50, 50T CDP 70, 70T</p>	<p>094333 094334 094335</p>
	DN 10 control valve and actuator for water heating coils	Comprises valve and actuator 230 V, ON/OFF (180 seconds from closed to fully open), includes union nut for Ø12 tube	<p>CDP 40 CDP 50 CDP 70 CDP 40T CDP 50T CDP 70T</p>	094340
	<p>Electric heating coil 2 kW Electric heating coil 3.5 kW Electric heating coil 5 kW</p>	Comprises electric heating coil, relays and electric wires	<p>CDP 40, 40T CDP 50, 50T CDP 70, 70T</p>	<p>094336 094337 094338</p>

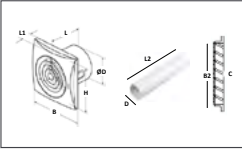
CDP 40-50-70 | CDP 40T-50T-70T

Illustration	Accessory	Description	Products	Code																														
	Pro 30 Standard Exhaust fan	<p>The exhaust fan can be used in combination with the CDP to either increase dehumidification capacity or establish outdoor air supply</p> <p>Pro 30 Standard: Power supply: 230 V/50Hz Power consumption: 7.5W Air volume: 97m³/h Sound level: 25 dB(A)</p> <p>Pro 32 Standard: Power supply: 230 V/50Hz Power consumption: 17W Air volume: 185m³/h Sound level: 32 dB(A)</p>	CDP 40 CDP 50 CDP 70 CDP 40T CDP 50T CDP 70T	094339																														
	Pro 32 Standard Exhaust fan	<p>Dimensions:</p> <table border="1"> <thead> <tr> <th></th> <th>Pro 30 Standard</th> <th>Pro 32 Standard</th> </tr> </thead> <tbody> <tr> <td>ØD</td> <td>99</td> <td>124</td> </tr> <tr> <td>B</td> <td>158</td> <td>182</td> </tr> <tr> <td>H</td> <td>136</td> <td>158</td> </tr> <tr> <td>L</td> <td>107</td> <td>91</td> </tr> <tr> <td>L1</td> <td>26</td> <td>27</td> </tr> <tr> <td>D</td> <td>100</td> <td>125</td> </tr> <tr> <td>L2</td> <td>500</td> <td>500</td> </tr> <tr> <td>B2</td> <td>100</td> <td>125</td> </tr> <tr> <td>C</td> <td>125</td> <td>150</td> </tr> </tbody> </table>		Pro 30 Standard	Pro 32 Standard	ØD	99	124	B	158	182	H	136	158	L	107	91	L1	26	27	D	100	125	L2	500	500	B2	100	125	C	125	150	CDP 40 CDP 50 CDP 70 CDP 40T CDP 50T CDP 70T	094341
	Pro 30 Standard	Pro 32 Standard																																
ØD	99	124																																
B	158	182																																
H	136	158																																
L	107	91																																
L1	26	27																																
D	100	125																																
L2	500	500																																
B2	100	125																																
C	125	150																																
	Through-wall duct kit with filter, extension kit and alu grill	<p>Comprises inlet and outlet section, grills, inlet filter and extension</p> <p>For walls between 70 and 366mm thickness</p>	CDP 40T CDP 50T CDP 70T	094271 094243 093508																														
	Duct lead-in adapter	<p>The adapter makes it possible to place CDP 40T-50T-70T on the wall without changing the existing wall openings</p>	CDP 40T CDP 50T CDP 70T	094801 094802 094804																														







CDP 40-50-70 | CDP 40T-50T-70T**Water heating coils – calculations at room temperature = 28°C; 60% RH**

CDP 40 + CDP 40T	Q=400 m³/h						
Water temperature	°C	82/71	80/60	70/35	90/70	60/40	55/45
Capacity	kW	3.32	2.64	0.68	3.4	1.02	1.36
Water flow rate	l/min	4.2	1.8	0.3	2.4	0.6	1.8
Water pressure drop	kPa	11.8	2.8	0.1	4.2	0.6	3.1
Water velocity	m/s	1.05	0.46	0.07	0.6	0.18	0.47
Air flow rate	m ³ /s	0.11	0.11	0.11	0.11	0.11	0.11
Inlet temperature	°C	82	80	70	90	60	55
Outlet temperature	°C	71	60	35	70	40	45
Air pressure drop	Pa	8	8	8	8	8	8
Connection tube	Ømm	12	12	12	12	12	12

CDP 50 + CDP 50T	Q=680 m³/h						
Water temperature	°C	82/71	80/60	70/35	90/70	60/40	55/45
Capacity	kW	5.28	4.27	0.99	5.45	1.82	2.2
Water flow rate	l/min	7.2	3	0.6	4.2	1.2	3
Water pressure drop	kPa	32.3	7.6	0.2	11.6	1.8	8.6
Water velocity	m/s	1.68	0.74	0.1	0.95	0.32	0.76
Air flow rate	m ³ /s	0.19	0.19	0.19	0.19	0.19	0.19
Inlet temperature	°C	82	80	70	90	60	55
Outlet temperature	°C	71	60	35	70	40	45
Air pressure drop	Pa	10	10	10	10	10	10
Connection tube	Ømm	12	12	12	12	12	12

CDP 70 + CDP 70T	Q=900 m³/h						
Water temperature	°C	82/71	80/60	70/35	90/70	60/40	55/45
Capacity	kW	7.56	6.23	2.37	7.9	2.83	3.23
Water flow rate	l/min	10.2	4.8	1.2	6	1.8	4.8
Water pressure drop	kPa	83	20.1	1.5	30.1	5.3	22.9
Water velocity	m/s	2.4	1.09	0.23	1.38	0.49	1.12
Air flow rate	m ³ /s	0.25	0.25	0.25	0.25	0.25	0.25
Inlet temperature	°C	82	80	70	90	60	55
Outlet temperature	°C	71	60	35	70	40	45
Air pressure drop	Pa	8	8	8	8	8	8
Connection tube	Ømm	12	12	12	12	12	12

CDF 10-40-50-70

Illustration	Accessory	Description	Products	Code
	Water tank	White or grey	CDF 10	351615 – White tank 351616 – Grey tank
	Remote control, DRC1	DRC1 is a wireless RH and temperature controller. Frequency: 433 mhz Range: Up to 50m depending on the conditions Protection class: IP20 Functionalities: <ul style="list-style-type: none"> • Reading and setting of RH, temperature, alarms and service information • Locking of settings 	CDF 40 CDF 50 CDF 70	112450
	External RH/t sensor	Remote sensor with 10 meter wire Protection class: IPX7	CDF 40 CDF 50 CDF 70	051710
	Floor mounting kit, 2 pcs - black	Each bracket to be mounted on each side of the dehumidifier	CDF 40 CDF 50 CDF 70	094332
	Water heating coil 2.6 kW* Water heating coil 4.2 kW* Water heating coil 6.2 kW*	Comprises water heating coil, flexible hose, fittings and gasket *at 80/60° C <i>(See technical specifications for water heating coils on separate page).</i>	CDF 40 CDF 50 CDF 70	094333 094334 094335
	DN 10 control valve and actuator for water heating coils	Comprises valve and actuator 230 V, ON/OFF (180 seconds from closed to fully open), includes union nut for Ø12 tube	CDF 40 CDF 50 CDF 70	094340
	Electric heating coil 2 kW Electric heating coil 3.5 kW Electric heating coil 5 kW	Comprises electric heating coil, relay and electric wires	CDF 40 CDF 50 CDF 70	094336 094337 094338

CDF 10-40-50-70

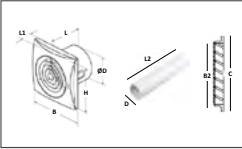
Illustration	Accessory	Description	Products	Code																														
	Pro 30 Standard Exhaust fan	<p>The exhaust fan can be used in combination with the CDP to either increase dehumidification capacity or establish outdoor air supply.</p> <p>Pro 30 Standard: Power supply: 230 V/50Hz Power consumption: 7.5W Air volume: 97m³/h Sound level: 25 dB(A)</p>	CDF 40 CDF 50 CDF 70	094339																														
	Pro 32 Standard Exhaust fan	<p>Pro 32 Standard: Power supply: 230 V/50Hz Power consumption: 17W Air volume: 185m³/h Sound level: 32 dB(A)</p> <p>Dimensions:</p> <table border="1"> <thead> <tr> <th></th> <th>Pro 30 Standard</th> <th>Pro 32 Standard</th> </tr> </thead> <tbody> <tr> <td>ØD</td> <td>99</td> <td>124</td> </tr> <tr> <td>B</td> <td>158</td> <td>182</td> </tr> <tr> <td>H</td> <td>136</td> <td>158</td> </tr> <tr> <td>L</td> <td>107</td> <td>91</td> </tr> <tr> <td>L1</td> <td>26</td> <td>27</td> </tr> <tr> <td>D</td> <td>100</td> <td>125</td> </tr> <tr> <td>L2</td> <td>500</td> <td>500</td> </tr> <tr> <td>B2</td> <td>100</td> <td>125</td> </tr> <tr> <td>C</td> <td>125</td> <td>150</td> </tr> </tbody> </table>		Pro 30 Standard	Pro 32 Standard	ØD	99	124	B	158	182	H	136	158	L	107	91	L1	26	27	D	100	125	L2	500	500	B2	100	125	C	125	150	CDF 40 CDF 50 CDF 70	094341
	Pro 30 Standard	Pro 32 Standard																																
ØD	99	124																																
B	158	182																																
H	136	158																																
L	107	91																																
L1	26	27																																
D	100	125																																
L2	500	500																																
B2	100	125																																
C	125	150																																

CDF 40-50-70





Water heating coils – calculations at room temperature = 20°C; 50% RH

CDF 40	Q=400 m ³ /h						
Water temperature	°C	82/71	80/60	70/35	90/70	60/40	55/45
Capacity	kW	3.85	3.19	1.16	3.94	1.64	1.91
Water flow rate	l/min	5.4	2.4	0.6	3	1.2	3
Water pressure drop	kPa	15.5	3.9	0.3	5.5	1.3	5.7
Water velocity	m/s	1.22	0.56	0.11	0.69	0.28	0.66
Air flow rate	m ³ /s	0.11	0.11	0.11	0.11	0.11	0.11
Inlet temperature	°C	82	80	70	90	60	55
Outlet temperature	°C	71	60	35	70	40	45
Air pressure drop	Pa	8	8	8	8	8	8
Connection tube	Ømm	12	12	12	12	12	12

CDF 50	Q=680 m ³ /h						
Water temperature	°C	82/71	80/60	70/35	90/70	60/40	55/45
Capacity	kW	6.11	5.12	2.42	6.29	2.75	3.08
Water flow rate	l/min	8.4	3.6	1.2	4.8	1.8	4.8
Water pressure drop	kPa	42.2	10.6	1.1	14.9	3.8	15.6
Water velocity	m/s	1.94	0.06	0.24	1.1	0.48	1.07
Air flow rate	m ³ /s	0.19	0.19	0.19	0.19	0.19	0.19
Inlet temperature	°C	82	80	70	90	60	55
Outlet temperature	°C	71	60	35	70	40	45
Air pressure drop	Pa	10	10	10	10	10	10
Connection tube	Ømm	12	12	12	12	12	12

CDF 70	Q=900 m ³ /h						
Water temperature	°C	82/71	80/60	70/35	90/70	60/40	55/45
Capacity	kW	8.74	7.43	3.86	9.07	4.12	4.47
Water flow rate	l/min	11.4	5.4	1.8	6.6	3	6.6
Water pressure drop	kPa	108.1	27.7	3.4	38.7	10.3	40.7
Water velocity	m/s	2.78	1.3	0.38	1.59	0.71	1.55
Air flow rate	m ³ /s	0.25	0.25	0.25	0.25	0.25	0.25
Inlet temperature	°C	82	80	70	90	60	55
Outlet temperature	°C	71	60	35	70	40	45
Air pressure drop	Pa	8	8	8	8	8	8
Connection tube	Ømm	12	12	12	12	12	12







AERIAL AD 110 & WT SERIES

Illustration	Accessory	Description	Products	Code
	Drain hose	Discharge of condensate 12 x 2mm Discharge of condensate 15 x 2mm	AD 110 WT series	2002052 2002053
	Hose clamp		AD 110, WT series	2003010
	PK-Uni pump kit	To use a pump for wall-mounted units	WT series	2002326
	Spare filter		AD 110	2001189
	Spare filter (gaze)		WT series	2001216

DHC 33-55-77

Optional accessories

Each unit comes with a wall-mounting installation bracket ready for easy installation of the new dehumidifier.
For added configuration of a given dehumidifier, please see the table below.

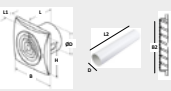
Illustration	Accessory	Description	Code
	Remote controller, DRC	Wireless remote controller for simple monitoring of room conditions and/or adjustability of setpoints. Frequency: 868MHz Range: up to 50m (depending on signal blockage from wall material, etc.) Reading and adjusting RH, temperature, alarms, and service information	112450
	External RH/T sensor	Remote combi sensor for relative humidity and temperature with a 10m wired connection.	051710
	Floor mounting kit, 2 pcs.	Two brackets for installation under the dehumidifier for floor mounting purposes. Colour: RAL 7010	30102148
	Water heating coil	Compact water heating coil for easy mounting on top of the condenser. The kit comprises of the water heater, flexible hoses, fittings, gaskets, and a relay. Capacities*: • 2.6 kW • 4.2 kW • 6.2 kW (*depending on dehumidifier size and in-/outlet temperatures. Here 80/60°C)	094333 094334 094335
	DN 10 control valve and actuator for water heating coils	Valve and 230 V actuator and for ON/OFF, with unit nuts Ø12mm	094340
	Electrical heating coils	Resistance heaters including relays and wires. Capacities*: • 2.0 kW • 3.5 kW • 5.0 kW (*depending on unit size)	094336 094337 094338
	Exhaust fan, low air flow	The exhaust fan can be used in combination with the DHC to either increase dehumidification capacity and/or ensuring negative pressure between the out- and inside. Low air flow: Power supply: 230 V/50 Hz Power consumption: 7.5W Air volume: 97m ³ /h Sound level: 25dB(A) Diameter: 100mm	094339
	Exhaust fan, high air flow	High air flow: Power supply: 230 V/50 Hz Power consumption: 17W Air volume: 185m ³ /h Sound level: 32dB(A) Diameter: 125mm	094341

TTR

Illustration	Accessory	Description	Products	Code
	G4 equivalent Z-line filter	Process air	TTR 800 TTR 1400 TTR 2000 TTR 2800 TTR 3700 TTR 5200 TTR 6600 TTR 8200 TTR 10000 TTR 12000 TTR 13500	2 x Art. no. 7.160.000.404 2 x Art. no. 7.160.000.404 1 x Art. no. 7.160.000.428 1 x Art. no. 7.160.000.428 1 x Art. no. 7.160.000.428 2 x Art. no. 7.160.000.448 2 x Art. no. 7.160.000.448 2 x Art. no. 7.160.000.448 2 x Art. no. 7.160.000.495 2 x Art. no. 7.160.000.495 2 x Art. no. 7.160.000.495
		Regeneration air	TTR 800 TTR 1400 TTR 2000 TTR 2800 TTR 3700 TTR 5200 TTR 6600 TTR 8200 TTR 10000 TTR 12000 TTR 13500	1 x Art. no. 7.160.000.404 1 x Art. no. 7.160.000.404 1 x Art. no. 7.160.000.404 1 x Art. no. 7.160.000.404 1 x Art. no. 7.160.000.404 1 x Art. no. 7.160.000.448 1 x Art. no. 7.160.000.448 1 x Art. no. 7.160.000.448 1 x Art. no. 7.160.000.475 1 x Art. no. 7.160.000.475 1 x Art. no. 7.160.000.475
	F7 equivalent pleated filter cartridge	Process air	TTR 800 TTR 1400 TTR 2000 TTR 2800 TTR 3700 TTR 5200 TTR 6600 TTR 8200 TTR 10000 TTR 12000 TTR 13500	2 x Art. no. 7.160.000.409 2 x Art. no. 7.160.000.409 1 x Art. no. 7.160.000.429 1 x Art. no. 7.160.000.429 1 x Art. no. 7.160.000.429 2 x Art. no. 7.160.000.449 2 x Art. no. 7.160.000.449 2 x Art. no. 7.160.000.449 2 x Art. no. 7.160.000.496 2 x Art. no. 7.160.000.496 2 x Art. no. 7.160.000.496
		Regeneration air	TTR 800 TTR 1400 TTR 2000 TTR 2800 TTR 3700 TTR 5200 TTR 6600 TTR 8200 TTR 10000 TTR 12000 TTR 13500	1 x Art. no. 7.160.000.409 1 x Art. no. 7.160.000.409 1 x Art. no. 7.160.000.409 1 x Art. no. 7.160.000.409 1 x Art. no. 7.160.000.409 1 x Art. no. 7.160.000.449 1 x Art. no. 7.160.000.449 1 x Art. no. 7.160.000.449 1 x Art. no. 7.160.000.476 1 x Art. no. 7.160.000.476 1 x Art. no. 7.160.000.476
	Tronect SP-T Tronect TF-L	Dry air inlet/outlet Ø250mm Humid air inlet/outlet Ø160mm	TTR 800/TTR 1400	6.100.001.202 Ø255mm 6.100.001.125 Ø160mm
		Dry air inlet/outlet Ø315mm Humid air inlet/outlet Ø200mm	TTR 2000/TTR 2800/ TTR 3700	6.100.001.210 Ø356mm 6.100.001.200 Ø203mm
		Dry air inlet/outlet Ø500mm Humid air inlet/outlet Ø300mm	TTR 5200/TTR 6600/ TTR 8200	6.100.001.216 Ø525mm 6.100.001.295 Ø305mm
		Dry air inlet/outlet Ø2 X 500mm Humid air inlet/outlet Ø400mm	TTR 10000/TTR 12000/ TTR 13500	6.100.001.216 Ø525mm 6.100.001.212 Ø425mm

DANTHERMGROUP



PROFESSIONAL INSTALLED
COOLING SOLUTIONS

FOR INDUSTRIAL, COMMERCIAL AND RESIDENTIAL PURPOSES

Dantherm[®]
CLIMATE SOLUTIONS

WHY CHOOSE BIOCOOL AIR COOLERS?

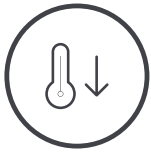

Reduces temperature between 7°C and 20°C by external conditions



No need to close doors or windows



Low energy consumption and spends up to 80% less than an A/C



Reduces static electricity



Improves air quality by moving dust, fumes and odours



Improves productivity in industries



Allows air-conditioning of certain areas



100% renewal of fresh and filtered outside air

Cooling solutions for

- Textiles
- Foundries
- Residences
- Sport centres and commercial buildings
- Food industry
- Technical rooms/data centres
- Ceramics
- Schools
- Laundries
- Greenhouses
- Pharmaceutical warehouses
- Car dealership/garages
- Plastics



OPERATION



Evaporative cooling is present in nature

Sometimes nature puts at our disposal resources that make our life more comfortable and respectful with the environment. The evaporative cooling is present in nature, in places close to the water as the waterfalls, lakes, seas and oceans and even on the human skin. The primitive men already applied rudimentary cooling techniques on the basis of this observation.

Biocool reproduces the effect of a sea breeze, driving fresh air where it may be needed.

A sustainable system

The Bio-air conditioning is a natural way of cooling, in addition is economic, healthy and ecological. This system allows the constant renewal of air, improving its quality as introduces clean and filtered air inside the space, evacuating bad odours, smoke and gases to the outside, allowing to maintain optimal ambient healthiness.



How it works?

As the air passes through the cooling pads, some of the heat is absorbed by natural evaporation and a fresh breeze is blown out. Temperature of the air emitted is between 4°C and 12°C lower than the outdoor air, at approximately 20 to 25°C."

The machine has automatic control which minimize maintenance and allow it to be adapted to different applications controlling the optimal desired conditions.

Energy consumption

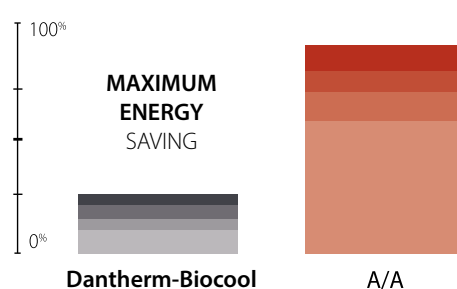

MAXIMUM QUALITY, EFFICIENCY AND INNOVATION



AIR PRE-FILTERING
Protects equipment from contaminants and aggressive environments.

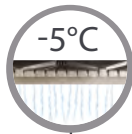

MAXIMUM PERFORMANCE
It cools up to 5°C more due to our water distributor that avoids clogging.



EFICOOL FILTERS
Optimum filter size for maximum cooling with minimum pressure drop.

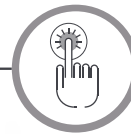

UPGRADEABLE EQUIPMENT
Upgradable control firmware.

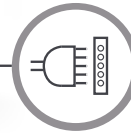

EASY INSTALLATION WITH QUICK CONNECTORS
Prevents failures and facilitates quick maintenance and installation.

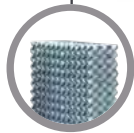

FIBERGLASS PANEL
New panels for maximum hygiene and durability. (Optional)



SAFETY SYSTEM
The equipment has an external disconnect for maintenance and a protection grid.



PURE WATER CONTROL
Clean water and tank for easy maintenance. Healthy and hygienic.



WINTER MODE
Closing dampers that avoid the chimney effect and drainage with the equipment off that allows the tank to be emptied in case of rain ingress.

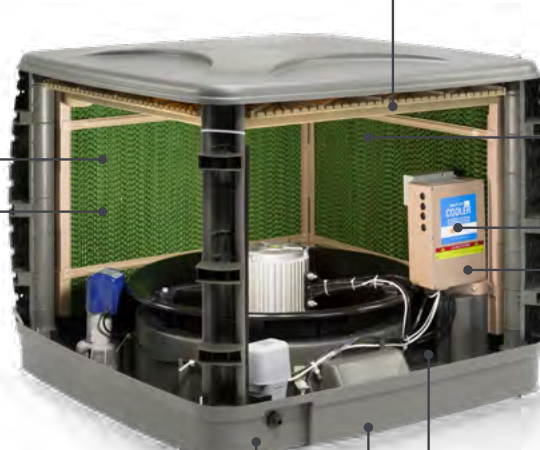

WATER CLEANING MANAGEMENT WITH OZONE ANTIMICROBIAL TECHNOLOGY

KEEPING YOUR UNIT CLEAN HAS NEVER BEEN SO EASY



BIO 18AIV



BIO 18AIV



- Simple installation
- Powerful fan
- Even distribution of water allowing maximum cooling efficiency
- Possibility to cool selected zones
- Automatic cleaning
- Ozone eliminates 100% of bacteria that can survive in still water
- Fast and quick maintenance
- External cut-off – integrated safety fuse
- Ducts automatic opening to avoid cold air entering from outside during winter and preventing hot air escaping from the inside
- Pre-filters prevent polluting particles being brought into the cooling pads (optional)
- Recommended for zonal or global coverage installations with uniform equipment distribution

Specifications	Units	BIO 18AIV
Air flow	m ³ /h	18,000
Cooling capacity	W	19,652
Fan type		Axial-Inverter
Max. energy consumption	W	1,200
Max. current	A	8
Fan diameter	mm	610
Max. fan speed	rpm	1,390
Power supply	V/Hz	220/1ph/50-60
Filter pad size	mm	825 x 620 x 100
Air exit		Top, side down
Water tank capacity	l	25
Remote control		Optional
Max sound level	dB(A)	<70
Product dimensions (l x w x h)	mm	1110 x 1110 x 950
Shipping dimensions (l x w x h)	mm	1170 x 1120 x 1050
Net/gross weight	kg	67/92

BIO 18CV DC



BIO 18CV DC

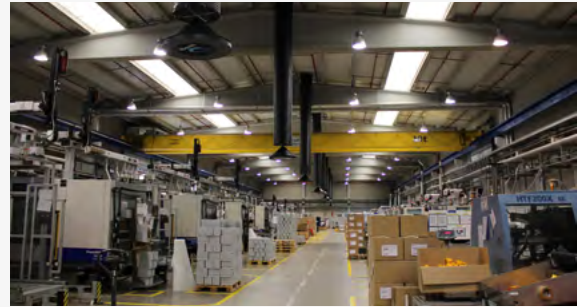

- Simple installation
- Powerful fan
- Even distribution of water allowing maximum cooling efficiency
- Possibility to cool selected zones
- Automatic cleaning
- Ozone eliminates 100% of bacteria that can survive in still water
- Fast and quick maintenance
- External cut-off – integrated safety fuse
- Ducts automatic opening to avoid cold air entering from outside during winter and preventing hot air escaping from the inside
- Pre-filters prevent polluting particles being brought into the cooling pads (optional)

Specifications	Units	BIO 18CV DC
Air flow	m ³ /h	18,000
Cooling capacity	W	18,290
Fan type		Centrifugal
Max. energy consumption	W	1,500
Max. current	A	9
Fan diameter	mm	650
Max. fan speed	rpm	-
Power supply	V/Hz	220/1ph/50-60
Filter pad size	mm	2 x (825 x 620 x 100) + 2 x (625 x 820 x 75)
Air exit		Down, Top
Water tank capacity	l	30
Remote control		Optional
Max sound level	dB(A)	<69
Product dimensions (l x w x h)	mm	1150 x 1150 x 950
Shipping dimensions (l x w x h)	mm	1170 x 1120 x 1050
Net/gross weight	kg	77/102

BIO 30AV



BIO 30AV



- Simple installation
- Powerful fan
- Even distribution of water allowing maximum cooling efficiency
- Possibility to cool selected zones
- Automatic cleaning
- Ozone eliminates 100% of bacteria that can survive in still water
- Fast and quick maintenance
- External cut-off – integrated safety fuse
- Pre-filters prevent polluting particles being brought into the cooling pads (optional)
- Recommended for installations that require large volumes of air supply as well as air diffusion over long distances

Specifications	Units	BIO 30AV
Air flow	m ³ /h	30,000
Cooling capacity	W	28,800
Fan type		Axial
Max. energy consumption	W	3,000
Max. current	A	7.1
Fan diameter	mm	710
Max. fan speed	rpm	1,490
Power supply	V/Hz	380/3ph/50-60
Filter pad size	mm	890 x 970 x 100
Air exit		Top, side, down
Water tank capacity	l	45
Remote control		Optional
Max sound level	dB(A)	<80
Product dimensions (l x w x h)	mm	1290 x 1290 x 1310
Shipping dimensions (l x w x h)	mm	1350 x 1350 x 1560
Net/gross weight	kg	120/165

BIO EXH



BIO EXH



- Simple installation
- Powerful fan
- Fast and quick maintenance
- External cut-off – integrated safety fuse
- Pre-filters prevent polluting particles being brought into the cooling pads
- Guarantees optimum operation of the installation by automatically adapting its extraction flow rate according to the in-flow rate of discharge at any given moment

Specifications	Units	BIO EXH
Air flow	m ³ /h	18,000
Cooling capacity	W	-
Fan type		Axial
Max. energy consumption	W	1,200
Max. current	A	360
Fan diameter	mm	5.6
Max. fan speed	rpm	600
Power supply	V/Hz	1390
Filter pad size	mm	220/1ph/50
Air exit		1100/60 to 200-264V
Water tank capacity	l	170-1,390
Remote control		Sí
Max sound level	dB(A)	<70
Product dimensions (l x w x h)	mm	1110 x 1110 x 950
Shipping dimensions (l x w x h)	mm	1170 x 1120 x 1050
Net/gross weight	kg	60/70

AIR DIFFUSERS

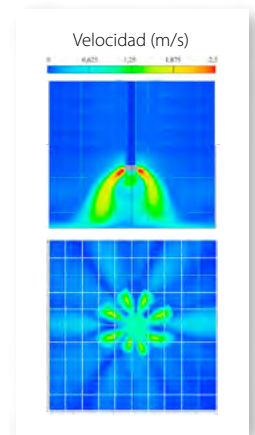
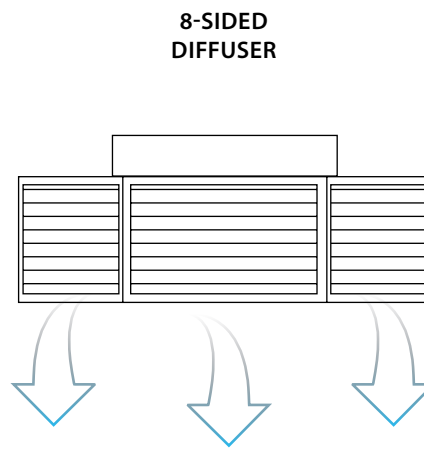
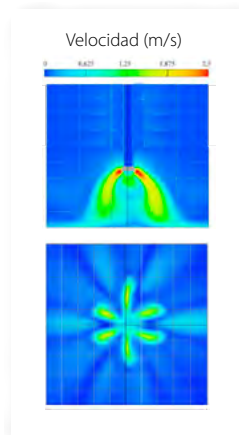
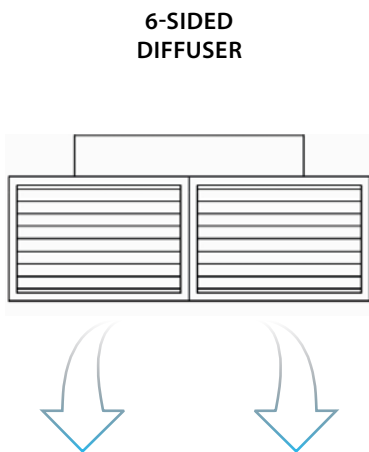
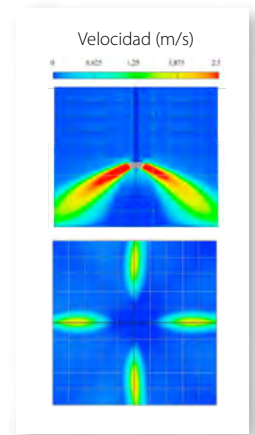
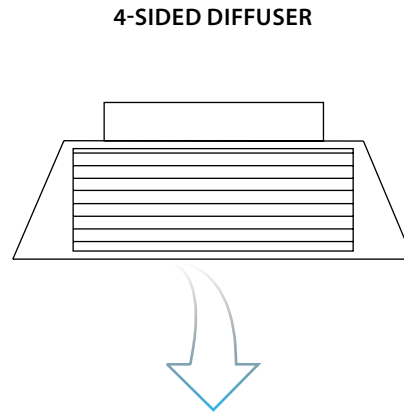
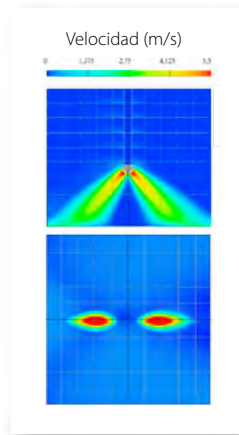
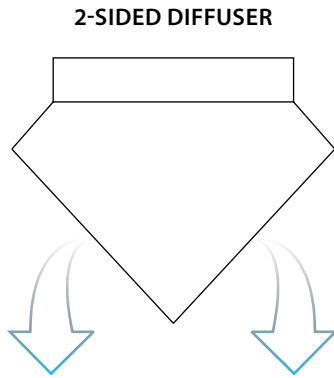

*AIR DIFFUSION STUDIES ENDORSED BY THE POLYTECHNIC UNIVERSITY OF VALENCIA.

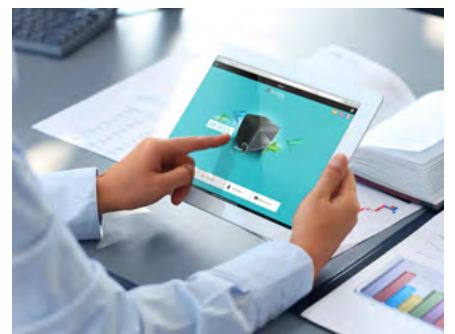

AIR DIFFUSERS

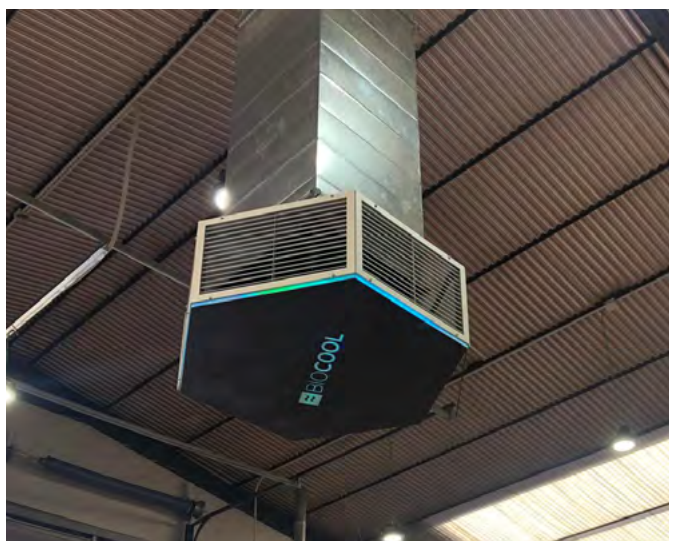



SMART CITY COOLER
CONTROL

- FROM THE OFFICE OR FROM OUTSIDE
- FROM PC, TABLET OR SMARTPHONE
- PLATFORM THAT ALLOWS GROUPING SEVERAL LOCATIONS
- HISTORICAL DATA LOGGING

THE MOST ADVANCED CONTROL SYSTEM ON THE MARKET

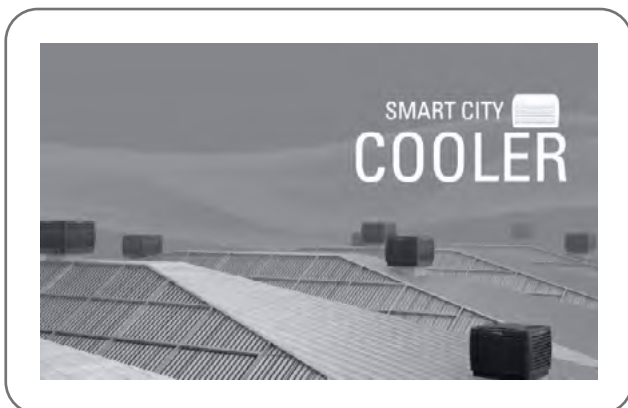

Group control up to 16 units supporting temperature sensor, ambient humidity for local management.

- Programming by humidity and/or temperature (3 preset programmable modes)
- Filter drying prior to shutdown to maximize hygiene
- Daily operation programming (up to 8 weekly events)
- External temperature and humidity sensor
- Adjustable drain time programming
- Fault and origin identification
- Allows limiting the humidity input that influences the ambient conditions
- Connectable to the local network to consult from PC, tablet or mobile in web environment
- Allows optimization of "freecooling" with external conditions sensor. T°C and RH%
- Logs historical sensor data and operating hours, downloadable to PC



MONITOR THE PERFORMANCE AND NEED FOR MAINTENANCE FROM YOUR TABLET OR PC



✓ **AIR QUALITY SYSTEM**
 FOR CO₂ CONTROL INCLUDED

Advanced control system that allows you to visualize and control the air quality, with AQS Alarm included to warn you if the air quality limit is exceeded. It also allows automatic ventilation regulation to improve air quality if it's necessary.



INTEGRABLE WITH:



SIEMENS





ADVANCED DIGITAL CONTROL



TOUCH CONTROL ADVANCED

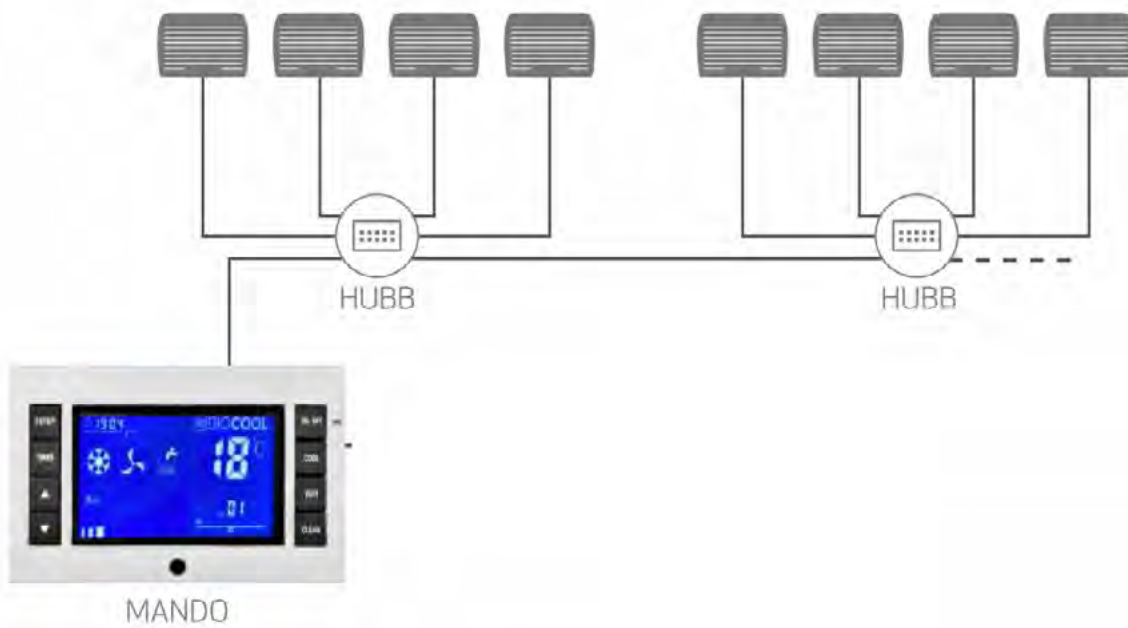

100% PARAMETERIZABLE CONTROL



AUTOMATIC CONTROL
 T°C/HR%



PURE WATER CONTROL
 INCLUDING



SAFETY RESET
 AUTOMATIC



GROUP CONTROL
 UP TO 40 UNITS



HOURLY PROGRAMMING
 WEEKLY



And much more...



DANTHERM GROUP

PROFESSIONAL INSTALLED

COOLING AND VENTILATION SOLUTIONS

FOR DATA CENTRES, TELECOM CABINETS AND INDUSTRY

Dantherm[®]
CLIMATE SOLUTIONS

Free-cooling
FLEXIBOX 900



FB 900

The Flexibox 900 offers cost-effective and controlled free-cooling ventilation. The solution cools by means of ambient air without using a compressor, generating significant savings in all climates.

The unit comes standard with the Dantherm-developed CC 3000 cooling controller, which allows for settings configuration and live operation monitoring on any standard browser.

The Flexibox 900 can be used as a stand-alone unit or in combination with e.g. existing air-conditioning. This ensures maximum use of passive cooling, prolongs the air-conditioner service life and generates significant OPEX savings.

These units are very suitable for retrofitting into existing systems. The return on investment for the retrofit is achieved especially quickly in base stations, where comfort air-conditioning units run 24/7.



- Extremely energy-efficient – savings in all types of climates
- Total heat management – control of multiple external units
- Stable operation – stepless fan speed control
- Clean internal environment – overpressure system
- Extended air path protection – Dantherm AirMaze
- Flexible installation – with variants for indoor and outdoor use
- Low maintenance costs – long-life compact filter
- Maximum security – remote monitoring and configuration
- Integrated CC 3000 control system

Specifications	Units	FB 900-48V	FB 900-230V
Operational temperature range	°C	-40/-25* to +55	-40/-25* to +45
Maximum cooling capacity at 25°C ambient, Δt = 10°C, 100%	W	8,140	8,610
Air flow – maximum	m ³ /h	2,450	2,590
Filter class		Coarse 60% (G4)	Coarse 60% (G4)
Input voltage range	VDC	48VDC (42-57VDC)	230V AC (200 to 277)
Power consumption 50/80/100%	W	78/239/366	71/284/400
Sound level, 50/80% @ 3m	dB(A)	47/56	49/59
Communication interface	Type	Ethernet SNMP	Ethernet SNMP
Controller		CC 3000	CC 3000
Product size outdoor (h x w x d)	mm	758 x 503 x 500	758 x 503 x 500
Product size indoor (h x w x d)		666 x 455 x 472	666 x 455 x 472
Net weight	kg	25	25

* Lowest operational temperature depends on installation

Free-cooling
FLEXIBOX 900



Flexibox 900 outdoor dimensions

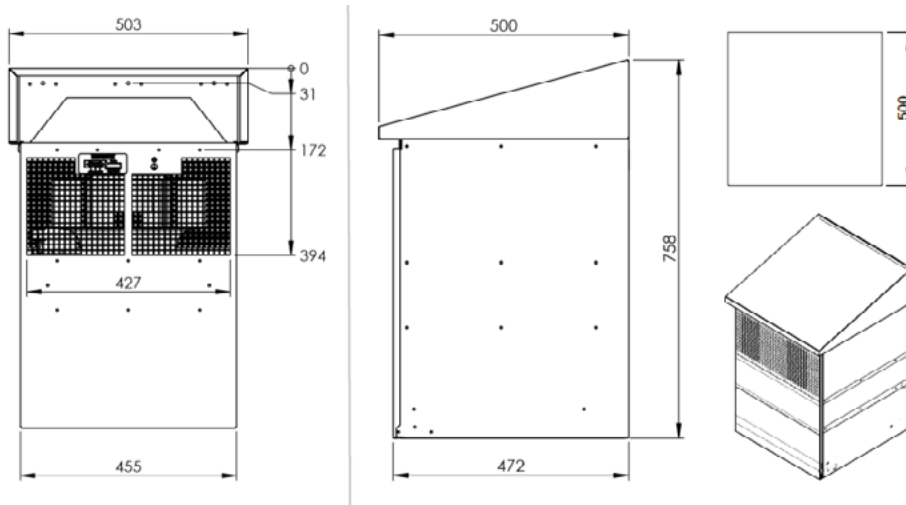

Flexibox 900 indoor dimensions

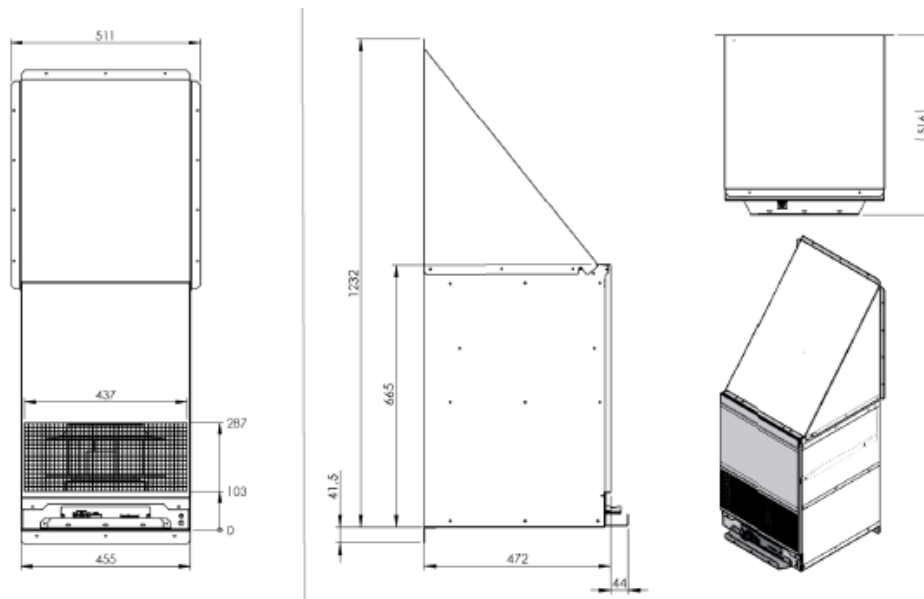

Flexibox flow and connection chart

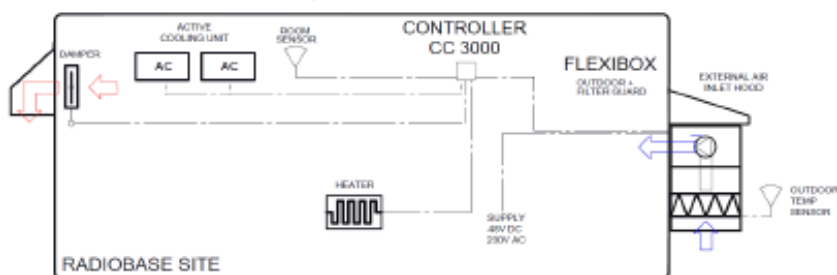

**FB 900
WITH BAG FILTER**

The Flexibox 900 with bag filter offers cost-effective and controlled free-cooling ventilation. The solution cools by means of ambient air without using a compressor, generating significant savings in all climates. The unit comes standard with the Dantherm-developed CC 3000 cooling controller, which allows for settings configuration and live operation monitoring on any standard browser.

The Flexibox 900 can be used stand-alone or combined with e.g. existing air-conditioning. This ensures maximum use of passive cooling, prolongs the air-conditioner service life and generates significant OPEX savings.

Fitted with a large bag filter this unit offers extended life time of the filter, thereby prolonging the intervals between filter changes.

These units are very suitable for retrofitting into existing systems. The return on investment for the retrofit is achieved especially quickly in base stations, where comfort air-conditioning units run 24/7.



- Extremely energy-efficient – savings in all types of climates
- Total heat management – control of multiple external units
- Stable operation – stepless fan speed control
- Clean internal environment – overpressure system
- Extended air path protection – Dantherm AirMaze
- Flexible installation – with variants for indoor and outdoor use
- Low maintenance costs
- Fitted with long-life bag filter for harsh environments
- Maximum security – remote monitoring and configuration
- Integrated CC 3000 control system

Specifications	Units	FB 900-230V
Operational temperature range	°C	-40*/-25 to +45
Maximum cooling capacity at 25°C ambient, Δt = 10°C, 100%	W	8,610
Air flow – maximum	m³/h	2,590
Filter class		ISO ePM10 60% (F6)
Input voltage range	VDC	230V AC (200 to 277)
Power consumption 50/80/100%	W	71/284/400
Sound level, 50/80% @ 3m	dB(A)	49/59
Communication interface	Type	Ethernet SNMP
Controller		CC 3000
Product size indoor (h x w x d)	mm	1078 x 455 x 472
Net weight	kg	28

* Lowest operational temperature depends on installation

Free-cooling

FLEXIBOX 900 WITH BAG FILTER

Dantherm[®]
CLIMATE SOLUTIONS

Flexibox 900 indoor dimensions

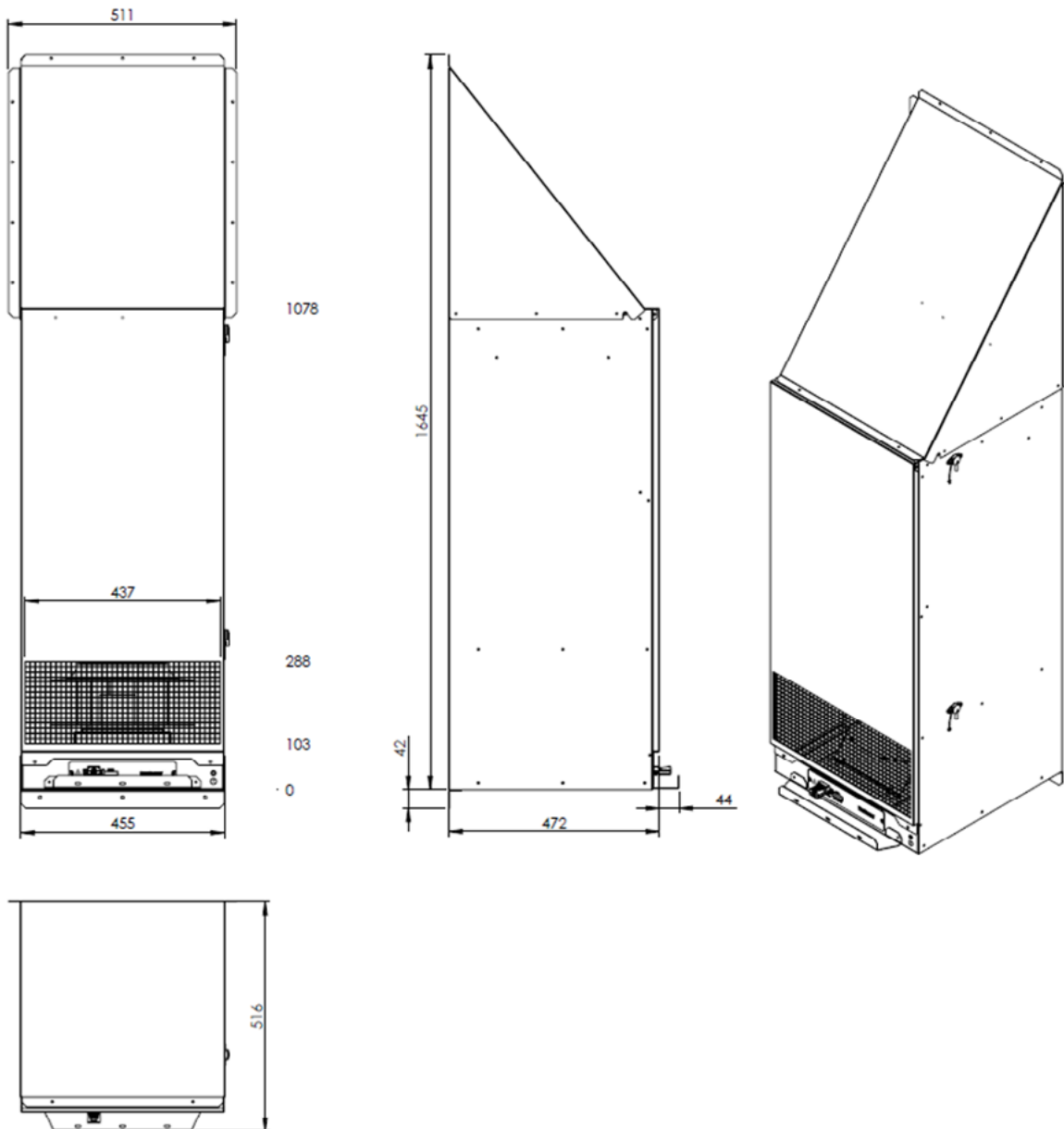

DFC 350-450



DFC 350



- Stay in control – total heat management with control of several external units
- Ensure energy-efficient cooling strategy – automatic change between cooling modes
- Protect your equipment – F5 displacement bag filter keeps your rooms clean
- Avoid unscheduled service visits – plan service with built-in filter monitor
- Silent and energy-efficient – very low air flow and fan speed
- Integrated CC 3000 control system

The Dantherm DFC 350 and 450 are slim passive cooling units utilising the displacement-free air cooling technology. The units are designed to remove excess heat from small rooms with electronic equipment where the air is stagnant.

Specifications	Units	DFC 350 48V DC	DFC 350 230V AC
Operational temperature range	°C	-40*/-25 to +55	-40*/-25 to +55
Maximum cooling capacity at 25°C ambient, Δt = 5°K	W	3,000	3,000
Air flow – maximum	m ³ /h	514	514
Filter class		ePM10 55% (F5)	ePM10 55% (F5)
Input voltage range	VDC	48VDC (42-57VDC)	230V AC (200 to 277)
Power consumption 50/80/100%	W	11/23/40	8/20/35
Sound level, 100% @ 3m	dB(A)	43	44
Controller	Type	CC 3000	CC 3000
Communication interface	Type	Ethernet SNMP, Modbus	Ethernet SNMP, Modbus
Protection	IP class	for indoor use	for indoor use
Product size (h x w x d)	mm	1982 x 385 x 166	1982 x 385 x 166
Net weight	kg	10	10

* Lowest operational temperature depends on installation

DFC 350 dimensions

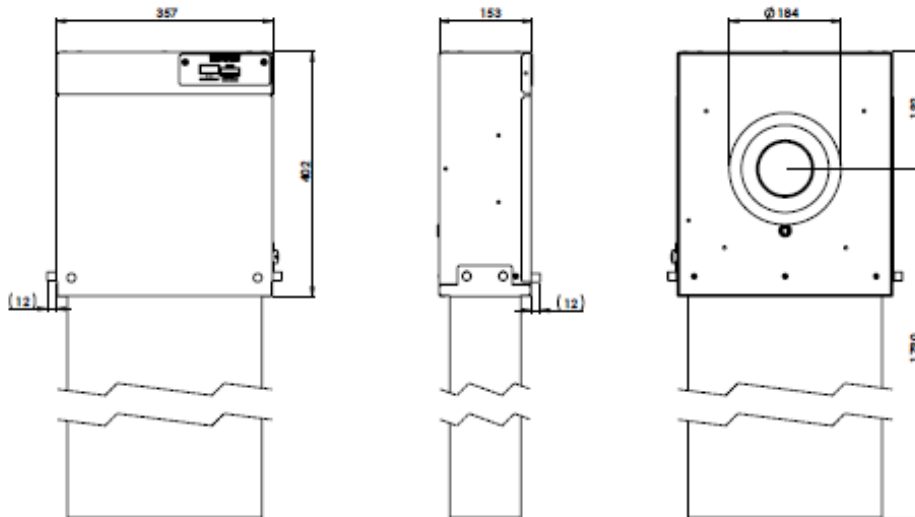

DFC 450 dimensions

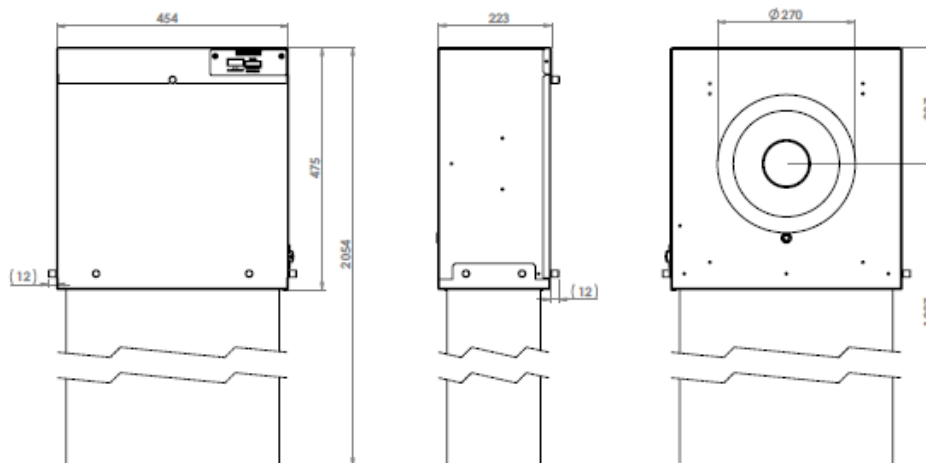

Specifications	Units	DFC 450 48V DC	DFC 450 230V AC
Operational temperature range	°C	-40*/-25 to +55	-40*/-25 to +55
Maximum cooling capacity at 25°C ambient, Δt = 5°K	W	5,000	5,000
Air flow – maximum	m ³ /h	1,100	1,100
Filter class		ePM10 55% (F5)	ePM10 55% (F5)
Input voltage range	VDC	48VDC (42-57VDC)	230V AC (200 to 277)
Power consumption 50/80/100%	W	12/25/40	16/41/61
Sound level, 100% – 3m distance	dB(A)	43	44
Controller	Type	CC 3000	CC 3000
Product size dimensions (h x w x d)	mm	2054 x 487 x 235	2054 x 487 x 235
Net weight	kg	13	13

* Lowest operational temperature depends on installation

COOLRACK

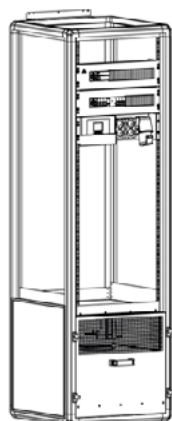

Coolrack is a combined cooling and rack unit. Coolrack is in principle a free-cooling unit that takes air in through the floor and filters it before letting it enter the room. Coolrack works together with a damper, by gravity or as a motorised unit.

Dantherm's unique CC 3000 control system comes standard with Coolrack. The system handles the climate control inside the shelter or technical room. External heaters, air-conditioners, dampers and fans can be connected to and controlled by the Coolrack unit.

Coolrack has 17 rack units (19") all free and reserved for customer equipment.



- Contains the complete electrical panel including circuitbreaker 3 x 400V 16A and RCCB (Residual Current Circuit Breaker)
- 1 pcs. 3x400V 16A for rectifier
- 1 pcs. 16A CEE outlet (3x400V)
- 4 pcs. Schuko outlet 230V 10A
- 1 pcs. heating cable 230V 10A
- Battery shelf
- 17 rack units (19") free for customer equipment
- Free-cooling units with integrated F5 filter
- Climate controller CC 3000 for securing the climate inside the technical room

Specifications	Units	COOLRACK
Air flow (at 53VDC)	m ³ /h	1,440
Cooling capacity at $\Delta T = 7^{\circ}C$	kW	3.4
Rated Voltage	VDC	48
Rated amps	A	2.8
Max power consumption	W	140
Max rpm	rpm	2,500
Filter class		ePM10 55% (F5)
Filter area	m ²	9,4
Pressure drop through clean filter	Pa	30
19" Rack units for customer equipment		17
Dimension (w x d x h)	mm	603 x 603 x 2000
Weight including frame and excluding batteries	kg	83
AC Voltage outlet		
3 x 400V, 16A CEE	pcs	1
1 x 230V, 10A CEE 7/3 (Schuko)	pcs	4

Cooling and rack unit
COOLRACK



Dimensions

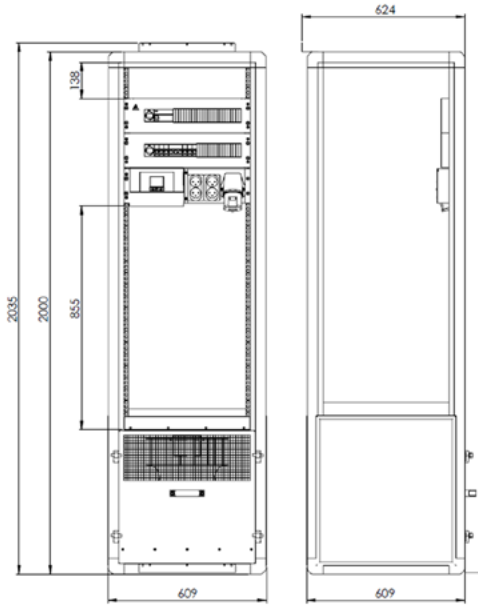

Function

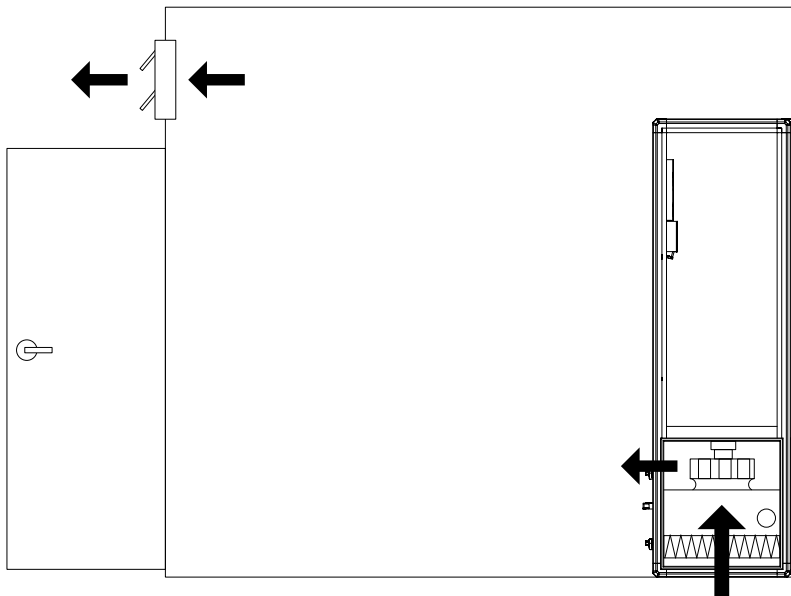

TKS 60



TKS 60

TKS 60 is high-capacity free air cooling designed to control the internal environment of communication shelters using a minimum of energy.

By means of ventilation in an overpressure system, the TKS 60 efficiently removes excess heat from the temperature-sensitive equipment – maintaining the internal temperature within defined limits.

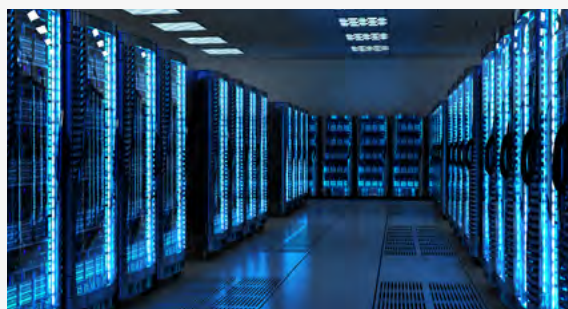

- Contains the complete electrical panel including circuitbreaker 3 x 400V 16A and RCCB (Residual Current Circuit Breaker)
- 1 pcs. 3x400V 16A for rectifier
- 1 pcs. 16A CEE outlet (3x400V)
- 4 pcs. Schuko outlet 230V 10A
- 1 pcs. heating cable 230V 10A
- Battery shelf
- 17 rack units (19") free for customer equipment
- Free-cooling units with integrated F5 filter
- Climate controller CC 3000 for securing the climate inside the technical room

Specifications	Units	TKS 60 230V AC	TKS 60 48V DC
Nominal air flow	m ³ /h	4,200	3,200
Nominal cooling capacity in W/K (Δt = 1°C)	W/K	1,400	1,050
Nominal fan power consumption (at 100% fan speed)	W	782	374
Filter class		ePM10 55% (F5)	ePM10 55% (F5)
Fan nominal voltage	V	230V AC	48 DC (42-57V DC)
Sounds pressure @ 1m	dB(A)	67	64
Controller	Type	CC 3000	CC 3000
Communication interface	Type	Ethernet SNMP, Modbus	Ethernet SNMP, Modbus
Product size (h x w x d)	mm	1100 x 600 x 600	1100 x 600 x 600
Net weight	kg	53	51



CC 3000

The Dantherm CC 3000 Cooling Controller for Telecom is designed for control and monitoring of free-cooling systems.

The controller has connections for up to two free-cooling units, e.g. Flexibox Free-cooling 900 series, TKS 60 and DFC products with or without motorised dampers.

In addition to controlling two free-cooling units, the CC 3000 can control a heater unit and two air conditioners.

CC 3000 includes graphic user interface (GUI) and WEB interface, WEB GUI and SNMP for access via any standard browser. The Dantherm CC 3000 optimises cooling performance with the lowest possible energy consumption.

Controllers make the real difference

A site-specific cooling solution is the way to begin reducing your energy bill intelligently, but the actual intelligence lies in the control of the units. That is why we have developed a line of controllers with intelligent control strategies, meaning that each controller solution is designed to control our product solutions according to the exact conditions at your site.

In other words, your equipment is protected according to customised settings, taking into consideration that your energy savings potential is fully utilised.



- Automatic restart after power failure
- Energy-saving mode that auto-reduces fan speed by measuring both room and outdoor temperature to secure the lowest fan speed and energy consumption
- Advanced night mode, where fan speed and noise level can be reduced during night time. It is also possible to change from air-conditioning to free-cooling operation
- Multi-lingual display
- Monitoring and alarm relaying (SNMP, Modbus, via dry contact (10 available))
- Self-test mode for easy installation
- Data-logging every 10 minutes
- Password protection
- Four different modes of operation possible:
 - Free-cooling mode (default)
 - Standard mode
 - Energy-saving mode
 - Air-conditioning mode

Unique control strategies for all scenarios

Dantherm’s controllers are all intelligent solutions that create the best possible climate conditions and savings at your site. The line features microprocessor-based climate controllers intended for controlling fan motors, dampers, compressors, air-conditioning systems, heaters, redundancy cooling, emergency cooling and much more.

Specifications	Units	CC 3000
Operational temperature range	°C	-30 to 85
Input voltage range	V	40 to 60
Product size	mm	200 x 215 x 90



The Dantherm CC 3000 control and monitoring unit for free-cooling applications is the key to truly intelligent handling of your entire climate control setup no matter where you are. With its browser-based remote control capabilities, the CC 3000 is capable of controlling two free-cooling units, a heater unit and two air conditioners. The free-cooling units may be with or without motorised dampers.

Reduced energy consumption

Based on years of development, the intelligent software enables the controller to optimise cooling performance in a way that reduces energy consumption to an absolute minimum. Creating a cooling solution dedicated to your site is the first step towards reduced energy consumption. Combining that with the CC 3000 intelligent control solution from Dantherm, which is tailored to fit the conditions of your project, protects your equipment while fully utilising your energy savings potential.

The CC 3000 controls fan motors, dampers, compressors, air-conditioning systems, heaters, redundancy cooling, emergency cooling and much, much more.

Remote and real-time control

You can access and configure all features of the controller remotely through a standard web browser. These include real-time system monitoring, configuration of digital inputs/outputs, firmware upgrades, backup/restore sessions and customised data collection.

Other clever features of the CC 3000 include dual-zone cooling, night mode, dual slope fan control, duration counters, integrated SD card for setup and logging, clock, calendar and much much more.

Complete climate control

- Customise controllers designed for total site energy efficiency
- Energy-optimised control strategies
- Remote access anywhere
- Maximum site uptime

Multiple application options

- All types of climates
- Challenging environments
- On-grid and off-grid
- New and legacy sites
- Remote sites

Proving the business case, Spain
Total site energy savings: 32%

Power consumption and operational logic, original cooling set-up

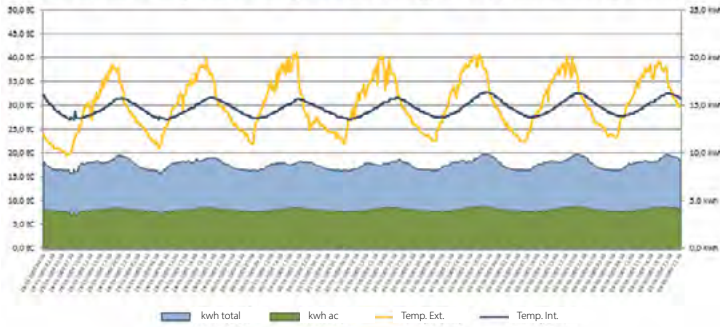

Power consumption and operational logic, Dantherm cooling set-up

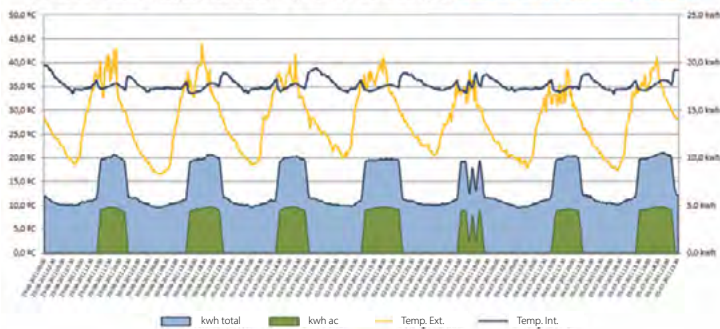

32%
Total site energy savings

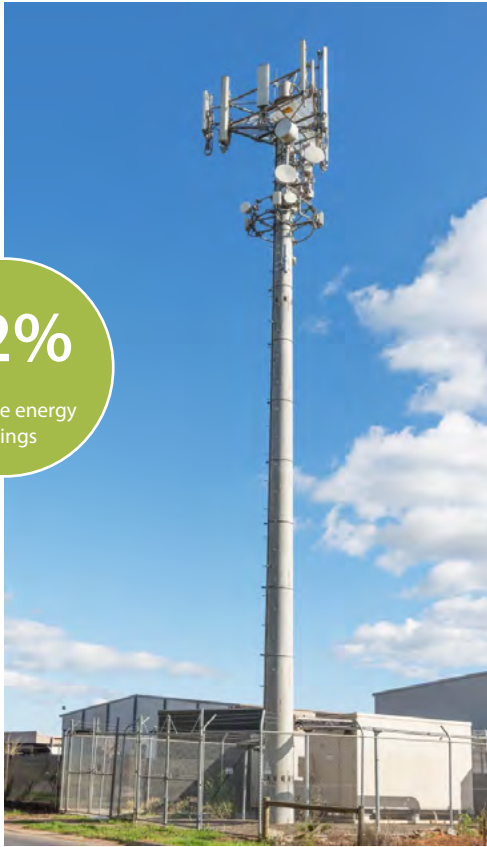

Free cooling advantages and savings

Smarter cooling strategies with dual zones

Air-conditioner only
Temperature in shelter (Zone 1) 26°C

OPEX	EUR	1.536
CAPEX	EUR	2.000
TCO 10yrs	EUR	19.362

Air-conditioner + Flexibox 900, 48 V DC
Temperature in shelter (Zone 1) 26°C

OPEX	EUR	1.478	8%
CAPEX	EUR	1.257	
TCO 10yrs	EUR	16.036	ROI 4.87

SAVINGS 10yrs EUR 3.326

Flexibox 900, 48 V DC + Battery Cooler
Temperature in shelter (Zone 1) 37°C
Temperature in Battery Cooler (Zone 2) 26°C

OPEX	EUR	547	68%
CAPEX	EUR	2.357	
TCO 10yrs	EUR	7.824	ROI 1.98

SAVINGS 10yrs EUR 11.538



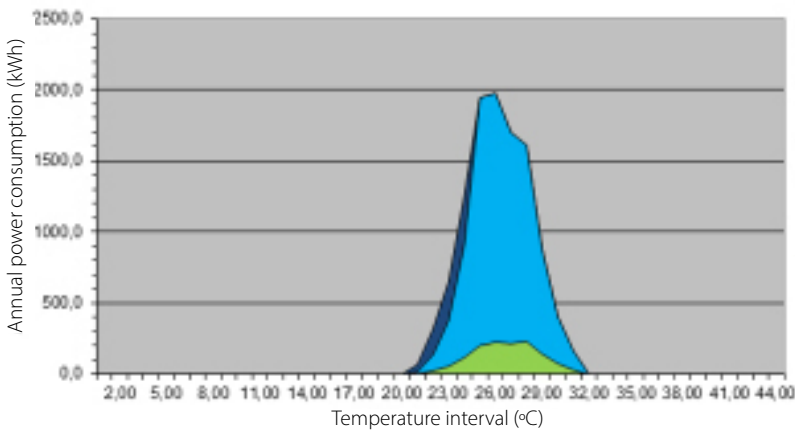

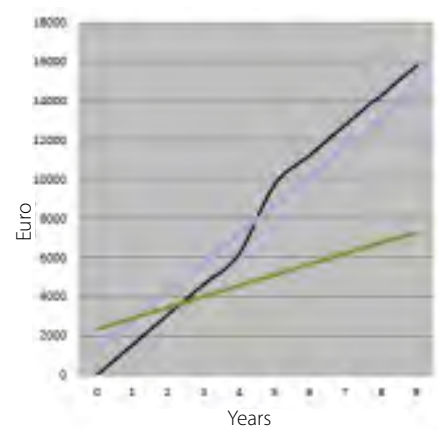

Power consumption comparison











TCO comparison









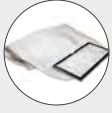

Controller accessories

Illustration	Accessory	Description	FB 810	FB 900	DFC 350-450	TKS 60	Code
	Humidity controller	Operation temperatures: -20°C to +50°C @ < 90%RH. The Humidity sensor has a cable length of 480mm and can be connected directly to CC 3000 controller, and the %RH is then shown in the CC 3000 display.	●	●	●	●	094166
	Heater relay	Relay for operating the electrical heater. Relay built in Box and including PG grommets. Max fuse: 10 Amps. 230V/50Hz. Dimensions: H x W x D: 130 x 130 x 99mm.	●	●	●	●	095842
	Air-con relay	Plastic box with relay and terminals. Relays for start and stop two external air-conditioners. Up to 16A. 1 phase system. 3 phase system.	●	●	●	●	089990
	Hot spot sensor with 8000mm cord		●	●	●	●	096873
	Dantherm RS485 display unit		●				075210
	SD card 2 GB for logging data		●	●	●	●	077213
	CC 3000 upgrade kit DC	The kit contains CC 3000, SD card with firmware and config files, room and outdoor temperature sensor, satellite PCB, communication cable between CC 3000 and satellite PCB.			●	●	094838





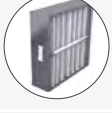
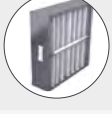
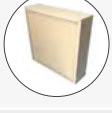
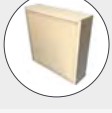



Dampers

Illustration	Accessory	Description	FB 810	FB 900	DFC 350	TKS 60	Code
	TC damper	Damper for re-circulation. Measurements: H x W x D: 487 x 455 x 150mm. To be installed between the wall and the unit.		●			091346
	Gravity damper (ABS plastic)	Opening: [407 x 407mm] Measurements: [456 x 456 x 27mm]	●	●		●	086964
	Gravity damper (Aluminium)	Opening: [400 x 400mm] Measurements: [442 x 442 x 50mm]	●	●		●	299943
	Gravity damper (Aluminium)	Inside measurements: 800 x 180mm Dimensions: H x W x D: 219 x 837 x 73mm	●	●	●	●	299945
	Gravity damper (ABS plastic)	Including bird net and mosquito net. Inside measurements: 310 x 310mm. Dimensions: H x W x D: 360 x 360 x 27mm.			●		098178
	Damper, motorised	Inside measurement: 300 x 311mm. Dimensions: H x W x D: 361 x 432 x 125mm.			●		074600
	Damper, motorised	Inside measurement: 400 x 411mm. Dimensions: H x W x D: 461 x 532 x 125mm.		●	●	●	074603
	Damper, motorised	Inside measurements: 800 x 211mm. Dimensions: H x W x D: 272 x 921 x 125mm.		●	●	●	074609
	Gravity damper (Aluminium)	Inside measurement: 600 x 400mm Dimension: H x W x D: 442 x 642 x 100mm		●			299944



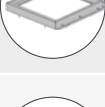

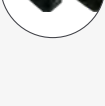



Filters

Illustration	Accessory	Description	FB 810	FB 900	DFC 350	TKS 60	Code
	Bag filter, ePM10 55% Bag (M5)	352 x 149 x 1600mm.					299821
	Bag filter, ePM2.5 50% Bag (F6)	352 x 149 x 1600mm.			●		067335
	Bag filter, ePM2.5 65% Bag (F7)	352 x 149 x 1600mm.			●		052319
	Bag filter, ePM10 55% Bag (M5)	450 x 215 x 1600mm.					299749
	Bag filter, ePM2.5 50% Bag (F6)	450 x 215 x 1600mm.					840058
	Bag filter, ePM2.5 65% Bag (F7)	450 x 215 x 1600mm.					054773
	Bag filter ePM10 50%, (M5)					●	087363
	Panel filter coarse 50% (G3)	450 x 450 x 130mm.		●			109264
	Panel filter coarse 60% (G4)	450 x 450 x 130mm.		●			075071
	Panel filter EPM10 55% (M5)	450 x 450 x 130mm.		●			299926
	Panel filter EPM2.5 65% (F7)	450 x 450 x 130mm.		●			840081
	Panel filter Coarse 60% [G4] for Combo cooler units	460 x 795 x 44mm.		●			217655

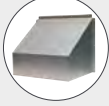



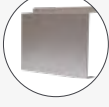
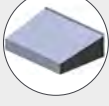

Installation equipment

Illustration	Accessory	Description	FB 810	FB 900 indoor	FB 900 outdoor	DFC 350	DFC 450	TKS 60	Code
	Adapter for ducting	Measurements: [450 x 450 x 70mm].	●	●					299648
	Duct mounting bracket	Measurements: [275 x 50 x 40mm].	●	●					299673
	Wall bracket for Flexibox	Measurements: [202 x 452 x 40mm].	●	●					299650
	Wall ducting	Adapter for installation of Ø400mm spiro duct.	●	●	●	●	●	●	299698
	Frame for air inlet from floor	Floor frame 450 x 450 x 50mm.	●	●					096733
	Grille for air inlet from floor	Grille air intake from floor, 450 x 450 x 0.8mm.	●	●					299647
	Wall bracket	Wall bracket and two bars for outdoor unit. Including screws. Dimension (H x L x W): 254 x 446 x 52mm.							092957
	Rubber feet	Light model rubber feet for outdoor unit made of durable recycled rubber. Reduces vibration from the unit and provides stability. Aluminium channel securely anchored in top for easy fixation of the unit. Quick and simple installation. Boxed kit with fixings. Including two bars and screws. Dimension (H x L x W): 95 x 450 x 160mm. Weight: 4.8kg.							097025
	Rubber feet	Heavy model rubber feet for outdoor unit made of durable recycled rubber which reduces vibration and provides stability. Aluminium channel securely anchored in top for easy fixation of the unit. Quick and simple installation. Boxed kit with fixings. Including two bars and screws. Dimension (H x L x W): 95 x 1000 x 160mm. Weight: 10.3kg.							097026

Weather protection

Illustration	Accessory	Description	FB 810	FB 900 indoor	FB 900 outdoor	DFC 350	DFC 450	TKS 60	Dampers	Code
	AirMaze panel unpainted	Unpainted, measurements: [1 149 x 735 x 120mm].	●	●	●			●	●	075575
	AirMaze panel painted	Painted, (not standard colour) with bug screen, measurements: [1 160 x 703 x 137mm].	●	●	●			●	●	086924
	AirMaze panel	AirMaze for DFC 350/450. Measurements: H x W x D: 744 x 472 x 137mm. The AirMaze gives weather protection for all DFC inlets and for damper outlets.				●	●			091265
	External rain hood	Opening: 513 x 607mm. Dimensions: H x W x D: 578 x 672 x 442mm. The rainhood gives weather protection for all DFC inlets and for damper outlets.	●	●	●	●	●	●	●	299653
	AirMaze panel unpainted	Dual AirMaze. Unpainted, measurements: [1 149 x 735 x 200mm].	●	●						109267
	AirMaze cube for outdoor Flexibox	Unpainted, measurements: [500 x 450 x 450mm].	●		●					081993
	External rain hood	Opening: 440 x 440mm. Dimensions: H x W x D: 472 x 500 x 300mm. The rainhood gives weather protection for damper outlet art. No: 074600 and 098178.	●			●	●		●	090768
	External rain hood	Opening: 800 x 200mm. Dimensions: H x W x D: 280 x 961 x 450mm. The rainhood gives weather protection for damper Art. No 299945, 074609 and 074611.							●	299942
	Damper rain/snow protection	Dimensions: H x W x D: 500 x 600 x 151mm. (Exhaust air only).							●	087317
	External rain hood	Opening 450 x 525mm. Dimension: 615 x 456 x 525mm. The rain hood can be used sound reduction.			●					095410
	External rain hood with sound insulation	Opening: 552 x 490mm. 30mm insulation foam. Dimensions: H x W x D: 889 x 673 x 455mm. The rain hood gives weather protection for damper Art. No 299945, 074609 and 074611.	●						●	095845



Installation equipment

Illustration	Accessory	Description	FB 810	FB 900 indoor	FB 900 outdoor	DF 350	DFC 450	TKS 60	Dampers	Code
	Absorber	Shock and vibration absorber includes a set of four absorbers for outdoor units. The absorbers can be mounted on wall brackets or ground mats.								074666
	Adapter	Adapter bars for mounting the outdoor unit on existing wall brackets. Including two bars and fixation. Length: 1000mm.								097027
	Condensate pump	Condensate pump for drainage for indoor unit. Voltage: 230V/50Hz. Max: 1.6 Amps Max. 200 litres per hour at lift height 4m. Tank capacity: 1.8 litre. For indoor use only. Kit includes: • Pump with tank and level sensor • 5m 3/8" tube for drainage outlet • Wall bracket is built in the tank								097028
	Copper tubes	3m copper tubes 3/8" & 1/2" with 10mm insulation and UV protection. Tubes are prepared for easy connection with flares and flare nuts.								097079
	Copper tubes	5m copper tubes 3/8" & 1/2" with 10mm insulation and UV protection. Tubes are prepared for easy connection with flares and flare nuts.								097029
	Copper tubes	10m copper tubes 3/8" & 1/2" with 10mm insulation and UV protection. Tubes are prepared for easy connection with flares and flare nuts.								097030
	Wall grille	Wall grille type V - 400 x 400mm. Exterior installation with insect net.	●	●	●			●	●	299947

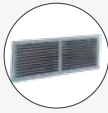
Installation equipment

Illustration	Accessory	Description	FB 810	FB 900 indoor	FB 900 outdoor	DF 350	DFC 450	TKS 60	Dampers	Code
	Wall grill	Wall grille type V - 300 x 300mm Exterior installation with insect net				●	●		●	299956
	Supply grill	Supply grille 400x200 (C-grillee) Adjustable slats	●		●					071679

Other accessories

Illustration	Accessory	Description	FB 810	FB 900 indoor	FB 900 outdoor	DF 350	DFC 450	TKS 60	Code
	Heater	Electrical heater 1380W, 230V AC Dimension: H x W x D: 180 x 135 x 48mm. Wall bracket included. The heater is a self-regulating PTC element with following performance of heating: -25°C up to 1380W 0°C up to 1200W +20°C up to 1000W	●	●	●	●	●	●	299879
	Internal air hood (Galvanised metal AZ150)	Dimension: H x W x D (w. mounting flanges): 580 x 560 x 580mm.						●	091436



DANTHERM GROUP

PROFESSIONAL INSTALLED
VENTILATION SOLUTIONS

FOR RESIDENTIAL BUILDINGS

Dantherm[®]
CLIMATE SOLUTIONS

High efficiency, low power consumption and low-noise balanced ventilation solutions.

Highly efficient heat exchangers and fans

Dantherm manufactures highly efficient alu heat exchangers – lightweight counter-flow heat exchangers in aluminium that deliver up to 86% efficiency at a minimal pressure loss. We also use plastic exchangers, with thermal efficiency of up to 96%. The ventilation units come with energy-efficient EC fan motors that help reduce energy consumption.

Enthalpy helps in all seasons of the year

Dantherm's enthalpy ventilation units offer a number of unique advantages compared to other types of counter-flow heat exchangers. By transferring humidity from the extract air to the supply air, the enthalpy exchanger prevents drying out of the indoor climate during the winter. In the summer, it removes humidity from the supply air. This way, the enthalpy exchanger maintains an optimal indoor air humidity (40-60%) throughout the year, thereby avoiding drying out and humidity issues. Moreover, the enthalpy exchanger significantly reduces energy consumption because it recovers heat and humidity very efficiently.

Fans

Dantherm's units are equipped with the latest EC (Electromagnetic Commutation) fan motor technology, so they are fitted with modern motors and fan rotors offering the very best in air technology and electrical efficiency. Thanks to the EC technology the bearings are the only moving parts to produce resistance, and therefore the lifetime of these fans is approximately ten years. The fans are connected to the controller of the fan unit and powered by 230V, and the stepless fan speed is controlled by a 0-10 volt signal.



Healthy and comfortable indoor climate

Why choose Dantherm Residential Ventilation?

- Danish design and quality since 1958
- Vast experience within residential ventilation
- Energy-efficient solutions
- Units for mounting on walls, attics, ceilings, and suspended ceilings
- Versatile unit configuration with L/R switch
- Smartphone App available
- Automatic free cooling
- Easy installation and user-friendly operation
- Trained and experienced service team

Frost protection

The intelligent control system prevents the heat exchanger from icing up. Frost protection is automatically activated at low outdoor temperatures. In areas where the outdoor temperature is frequently lower than minus 3°C, preheating coils are recommended to heat the outdoor air before it enters the heat exchanger.

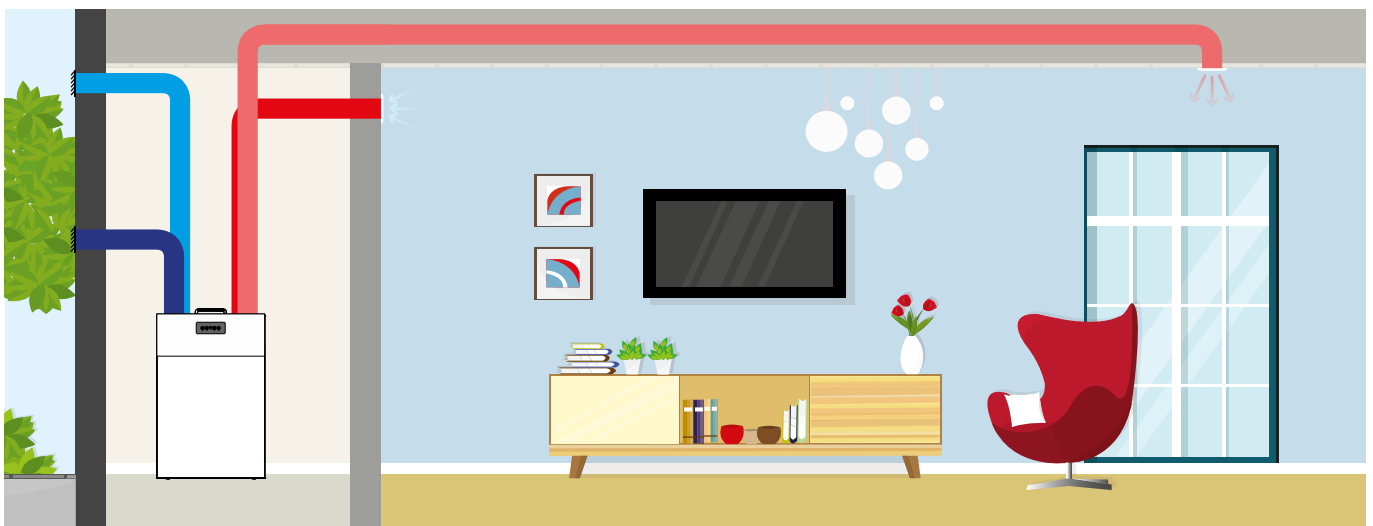

Automatic and manual free cooling

Dantherm residential ventilation units have an inbuilt automatic by-pass function to obtain 100% free cooling with outdoor air. The by-pass opens and closes automatically depending on the extract air temperature readings and settings. Moreover, a manual by-pass function can be activated whenever required, allowing the fresh outdoor air to move through the unit without passing through the heat exchanger. It is activated with one of the control interfaces – the built-in control panel, wireless remote control, wired control, the Dantherm App, or the Dantherm PC Tool. At outdoor temperatures below 9°C, the by-pass is blocked due to the risk of condensation.

Optional demand-controlled ventilation

The units deliver a comfortable indoor climate in all conditions at a minimal power consumption by means of automatic demand-controlled ventilation. This is obtained through the application of a humidity sensor, a VOC sensor and/or a CO₂ sensor. The humidity sensor (RH%) continuously monitors extract air humidity and adjusts the fan speed accordingly. The VOC sensor continuously monitors the level of artificial or natural organic chemicals of the extract air and adjusts the air flow level accordingly. Once installed in a room and connected to the HAC accessory control unit, the CO₂ sensor continuously monitors the CO₂ level and adjusts the air change accordingly.

Filters

All Dantherm residential ventilation units are fitted with G4 filters as standard for both supply air and extract air. This filter will meet the majority of air cleaning needs. F7 pollen and dust filters are available as optional accessories. F7 filters will ensure that allergens do not enter the house through the ventilation system.

VOC air quality demand sensor

The units can be fitted with a VOC air quality sensor. This sensor will continuously monitor the level of artificial as well as natural organic fumes in the air.

Examples of included fumes:

- Natural fumes, e.g. formaldehyde from building materials
- Chemical fumes from sprays, e.g. hair spray or perfumes
- Indoor pollution e.g. from smoking and printing with laser printer
- Fumes from fire-retardant substances in carpets, paint and furniture

Using the VOC sensor in demand mode will result in the correct level of ventilation with the lowest possible power consumption. If a wireless remote control or App is connected, the actual VOC level will be shown in the display using a 3 level icon.

RH% demand sensor

The residential ventilation units are fitted with a humidity sensor (RH%). This sensor will continuously monitor the humidity of the extract air and adjust the air flow level accordingly. This operation is named demand mode. If a wireless remote control is connected, the level will be shown in the display using a 3 level icon. Using demand mode will result in the correct level of ventilation at the lowest possible electrical power consumption. If both VOC and RH% sensors are fitted, the ventilation level is determined by the highest demand from just any one of the sensors.

Leakage protection

All the Dantherm units have the best class of protection for external and internal leakages, according to EN 13141-7 <2% (Class A1).

Maintenance

Dantherm residential ventilation units are virtually maintenance-free. We recommend filters to be changed twice a year to maintain optimum performance. An alarm will indicate when the filters need to be replaced with new ones. Apart from changing the filters and cleaning the outside of the unit, any other form of service has to be carried out by qualified personnel.



VENTILATION WITH HEAT RECOVERY

The intelligent control system of the HCV systems ensures that the heat exchanger does not ice up.

The preheating process is controlled through monitoring of temperatures registered by all sensors inside the unit and its purpose is primarily to prevent the icing inside the heat exchanger. Depending on the overall temperature conditions and in order to save energy, the control will continuously attempt to exploit as little of available preheater capacity as possible.

When the preheater is active, the temperature of the outdoor air will be increased to maintain a stable airflow and stable operation of the unit as a whole. Nevertheless, if some harsh conditions appear in which the preheating coil can no longer ensure frost-proof operation, the defrosting program will be activated.

The effects experienced during the period of time in which the preheater is active will be a higher exhaust air temperature and a slightly higher supply air temperature.

If needed, further improvements and adjustments of the supply air temperature can be achieved if an after-heater is applied.

Defrost: An optimal operation at low outdoor temperatures is ensured by use of preheating coil.

Defrosting process is the only operation mode left to protect the heat exchanger from icing in following cases:

- Where the unit is not fitted with a preheating coil
- Where the unit is fitted with a preheating coil but where the outdoor temperature conditions are so extreme so that the preheater capacity is no longer enough

The defrost mode is a temporary one, controlled in a similar manner as the preheating. Defrosting will be aborted as soon as the system can register the temperatures that allow a normal operation.

Info: The defrost mode is a safety mode. During defrosting the unit cannot change to another operating mode until defrosting is completed.

- No fireplace in the house (default setting)
- Fireplace in the house

The standard frost protection process creates a negative pressure in the dwelling. If the dwelling envelope is completely airtight and the "missing" supply air cannot enter the dwelling via other ways, defrosting is not as efficient and is only performed in low/freezing temperature conditions. NOTICE! Under such conditions, we strongly recommend using a preheating coil.

In areas where the outdoor temperatures are often lower than -6°C, you can easily mount preheating to continue to ensure a balanced and reliable solution.

Dantherm uses 3 types of counter-flow heat exchangers

Aluminium exchangers Characterised by low pressure loss, good sound reduction and high air output.

Plastic exchangers Similar to aluminium exchangers, but tend to have better thermal efficiency.

Enthalpy heat exchangers A special polymer membrane capable of transferring up to 65% of the humidity



Aluminium and plastic heat exchanger
Sensible energy (heat) is recovered from the extract air and transferred to the fresh supply air.



Enthalpy heat exchanger
Sensible energy (heat) and latent energy (humidity) is recovered from the extract air and transferred to the fresh supply air.

Enthalpy heat exchangers pass both heat and moisture from one airstream to the other. This keeps humidity within a building at a consistent, comfortable level throughout the year.

Conventional HRV heat exchangers are based on the condensation of water on the walls inside of the exchanger. This is designed to increase the efficiency of the exchanger, but means that condensate is left behind. In contrast, an enthalpy heat exchanger is made from a special polymer membrane. This material allows moisture to penetrate it, unlike the aluminium or plastic used in a traditional heat exchanger. Therefore, an enthalpy heat exchanger allows both heat and moisture to be passed from one airstream to the other. This means that the humidity within a building is kept at a consistent, comfortable level, removing the risk of excessive dryness.



The benefits of enthalpy

First and foremost, by allowing for efficient humidity recovery, an enthalpy heat exchanger avoids any of the consequences typically associated with low humidity. These include damage to wooden fixtures and furniture, wall cracks and also health issues like chapped lips, itchy eyes, headache or flaky skin. Instead, relative humidity will be maintained at a comfortable, pleasant level, protecting the health and wellbeing of both residents and buildings.

With an enthalpy heat exchanger, because moisture passes through the polymer membrane and across airstreams, very little (if any) condensate will be left behind. This means that the heat exchanger will be at no risk of freezing. This greatly reduced risk of freezing ensures that enthalpy heat exchangers are noticeably more efficient during the colder months of the year. In the winter, the thermal efficiency of an ERV unit greatly outmatches a conventional HRV unit. In addition, the enthalpy heat exchangers in Dantherm units can function down to -5°C , without any preheating. This guarantees balanced ventilation for the main part of the year without preheating, which in turn reduces residents' heating and electricity bills.

The advanced polymer membrane used in these enthalpy heat exchangers blocks the transfer of any odours or contaminants between airstreams, without compromising the transfer of heat and humidity. This removes the risk of bacteria or viruses in the stale air inside the building being recycled back into the supply air. Furthermore, the membrane contains built-in antimicrobial technology, making it resistant to both mould and bacteria. This ensures our enthalpy heat exchangers are extremely hygienic, and no danger to the residents who benefit from the ventilation unit.

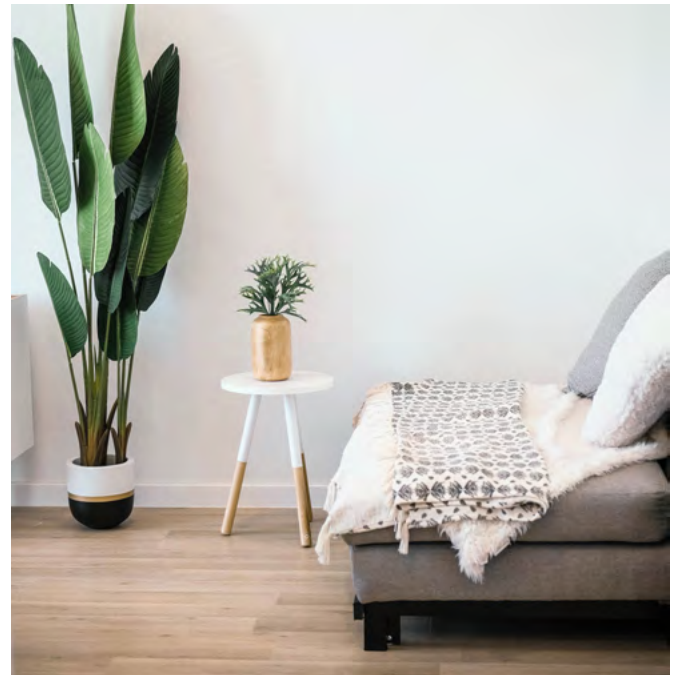



For a quick selection of the product range, you can use the selection chart below. The selection chart shows the air volumes at 100Pa pressure loss.

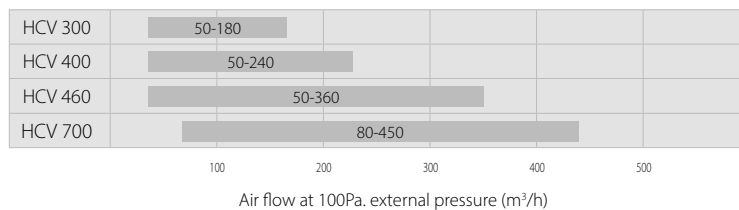

Overview

The HCV 300-400-460-700 residential ventilation units are primarily designed for villas and apartments. They meet ventilation requirements of houses up to 450m² or more, depending on national requirements and the actual pressure loss in the installation.

The units are supplied as packaged basic ventilation units complete with built-in control panel, and are delivered with all parts necessary for wall installation. A wide range of additional accessories are available.

The residential ventilation units are fitted with highly efficient counter-flow heat exchangers, which are optimised to a high efficiency level, thus achieving a low power consumption (SPI value) for the entire unit.

Model range

The HCV 300 unit is perfect for concealed installation instead of in a 60 x 60cm cupboard module, e.g. in a modern utility room environment, where everything is hidden behind doors. All ducts are connected to the top of the unit. On the HCV 300 and HCV 400, it is also possible to connect the supply duct to the base if ducts are to run beneath the floor.

HCV 400 and HCV 460 fit into a standard 60 x 60cm cupboard module.

HCV 700 is ideal for free wall installation with minimum 700mm space. A standard wall rail is supplied with all units.



Features

All units are equipped with easy-access filter slots behind the upper front cover. The control panel with LED light indicators is located in an opening in the front cover.

Cabinet

The HCV insulation is made of expanded polystyrene (EPS) components with a minimum wall thickness of 32mm. This allows the units to be placed in rooms with temperatures as low as +12°C.

The outer surface is made of 0.8mm powder-coated sheet metal and painted in RAL 9016. The HCV series complies with European fire safety requirements as specified in EN 13501 class E.

The leakage rate of the unit (internal and external) is <2% as specified in EN13141-7 leakage class A1.

Function

The unit ventilates residential homes by extracting the inside humid air, and replacing it with fresh outside air, which has been heated with the heat energy of the extracted air. This reduces energy consumption.

The air volume can be controlled by:

- Selecting a fixed fan speed from 0-4
- Demand mode, in which a built in RH sensor continuously adjusts the fan speed depending on any immediate demand, determined by the humidity of the extracted air
- Week timer program – the fan speed will increase or decrease according to an hourly time schedule, or specific demand

When very humid inside air is extracted, the humidity will condensate inside the heat exchanger and be collected by the embedded drip tray. This water is drained from the unit through the enclosed hose and then disposed of in the nearest drainage.

Installation

After installation of the unit, ducts and condensate hose, the unit needs to be calibrated to the specific environment. Measurements of air volumes are carried out via built-in air pressure spigots. Appropriate initial adjustments are performed directly on the control panel or with Dantherm PC Tool.

An air flow diagram is present on the front cover, showing the pressure and air volumes the installer must use to calibrate the two air flows (see example opposite).

A) LEFT SET-UPS
 STANDARD CONFIGURATION

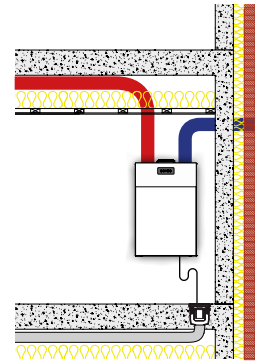

(B) RIGHT SET-UPS
 CAN BE CONFIGURED ON SITE

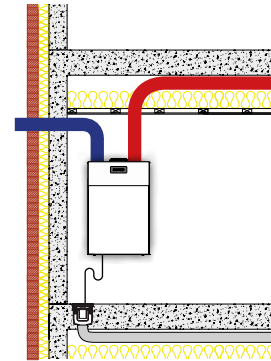

Maintenance

In general, the only regular maintenance required by the HCV residential ventilation units is to check/change the air filters once a year when the alarm is triggered (flashing LED and acoustic alarm).

The user changes the filter by opening the filter cover, changing the filters and resetting the filter timer on the built-in control panel.

Apart from changing the air filters and cleaning the outside of the unit, any other form of service will have to be carried out by qualified personnel.

Local Dantherm partners are always available with support to solve any problem that might arise with the unit.

Removing the front cover gives access to all types of service and repair.

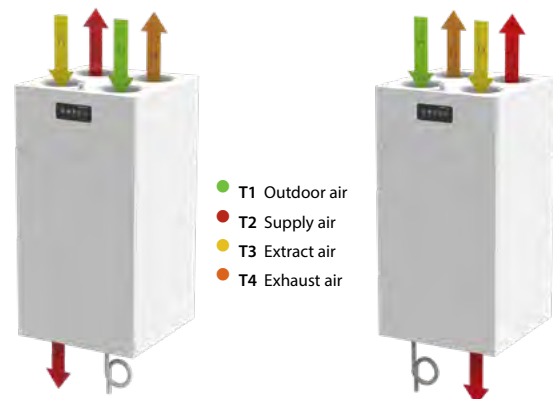

HCV 300



HCV 300

The HCV 300 is a highly efficient residential ventilation unit for houses, villas, and apartments. It comes as a packaged basic ventilation unit complete with built-in control panel, and is delivered with all parts necessary for wall installation.

The HCV 300 is either delivered in RAL 9016 cabinet colour and packaged individually one unit on a pallet or in a variant without filter lid and with a galvanised metal surface packaged four units on a pallet to minimise use of packaging in consideration of the environment and to ease handling at building sites.



- Demand-controlled ventilation with integrated humidity sensor, reducing power consumption at times with low ventilation demands
- Reduced power consumption at times with low ventilation demands
- Summer mode in which supply fan is stopped and any open window will supply cooler outside air, lowering the room temperature
- Automatic free-cooling features, via an inbuilt 100% by-pass, including the possibility of increasing the air flow automatically, lets in cool night air following hot days to help maintain a comfortable temperature throughout the day
- Fireplace mode, creating a temporary inside overpressure to enhance chimney functionality
- High-efficiency heat recovery
- EC fan motors with extremely low energy consumption (low SPI)
- Highly customisable units with options to add a high variety of internal as well as external accessories
- HCV 300 models take up less space than a 60 x 60cm cupboard and are perfect for concealed installation
- Ducts can be connected to the top of the unit, with the option to connect the supply duct to the base if ducts are to run beneath the floor

Third part tests and certifications

Code	Description
DIBt Pending	Certified by the German Institute of Construction Technology
PHI	Passivhaus certified
ErP	Compliant with EU regulations for Eco-design
EPB	Listed in the database for Energy Performance of Buildings in Belgium
Nordic Swan Ecolabel	Listed in the Nordic Swan database for products suitable for Ecolabelled buildings
EPD	Environmental product declaration for declared product variant is available in the epddanmark.dk database

Specifications	Units		HCV 300
Maximum achievable flow at 100Pa	V100Pa	m ³ /h	280
Maximum declared flow at 100Pa	V _{max.rated}	m ³ /h	180
Recommended operating range	V	m ³ /h	50-180
EN 13141-7 reference flow	50Pa	m ³ /h	126
Performance			
Thermal efficiency in accordance with EN13141-7	η_{SUP}	%	86
Specific power consumption in accordance with EN13141-7	SFP	W/m ³ /h	0.28
Leakage (external and internal) in accordance with EN13141-7	-	%	<2% (Class A1)
Filters in accordance with ISO16890	-	-	ISO Coarse 75% (optional on supply: ePM1>50%)
Filters in accordance with EN779	-	-	G4 (optional on supply: F7)
Installation surrounding temperature	t _{SURR}	°C	+12 to +50
Outdoor temperature without preheater installed	t _{ODA}	°C	-12* to +50
Outdoor temperature with preheater installed	t _{ODA}	°C	-20 to +50
Maximum absolute humidity in extract air	x	g/kg	10
Cabinet			
Exterior dimensions without wall brackets	w x d x h	mm	600 x 430 x 1000
Spigots/duct connections	Ø	mm	125 – female
Weight		kg	36
Heat conductivity – polystyrene insulation	λ	W/mK	0.031
Heat transition figures – polystyrene insulation	U	W/m ² K	<1
Fire classification of the polystyrene insulation	class	-	DIN 4102-1 class B2 EN 13501 class E
Drainage hose	Ø/length	"/m	¾/1
Cabinet colour	RAL	-	9016/galvanised metal grey
Electrical			
Voltage	U	V	230
Maximum power consumption without/with preheater	P	W	170/870
Frequency	f	Hz	50
Protection class	-	-	IP21

*The use of the preheating coil is recommended at outdoor temperatures below -3°C to ensure balanced ventilation.

Capacity and SPI curves with G4/G4 filters

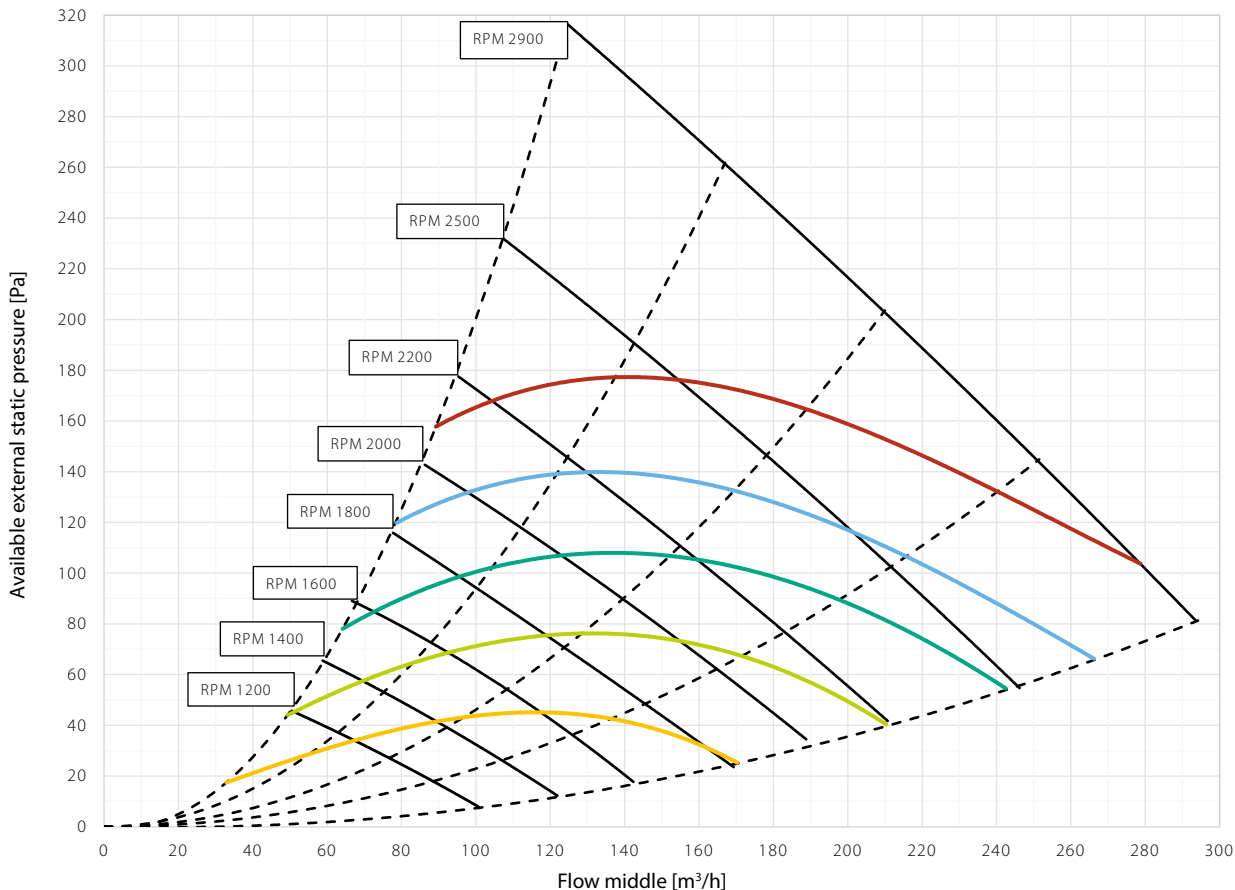

	—	—	—	—	—
SFP/SPI/SEL*	0.45 W/m ³ /h	0.39 W/m ³ /h	0.33 W/m ³ /h	0.28 W/m ³ /h	0.22 W/m ³ /h
	1620 J/m ³	1400 J/m ³	1200 J/m ³	1000 J/m ³	800 J/m ³
	1.62 W/l/s	1.40 W/l/s	1.20 W/l/s	1.0 W/l/s	0.80 W/l/s

* SFP/SPI/SEL includes power consumption of both fans and the control

Thermal efficiency curves

Legend

- Thermal efficiency according to EN 13141-7 (dry)
Operational conditions: outdoor air: 7°C, 85% RH; extract air: 20°C, 38% RH
- Thermal efficiency according to EN 13141-7 (with condensation)
Operational conditions: outdoor air: 2°C, 80% RH; extract air: 20°C, 60% RH

All values at balanced flow

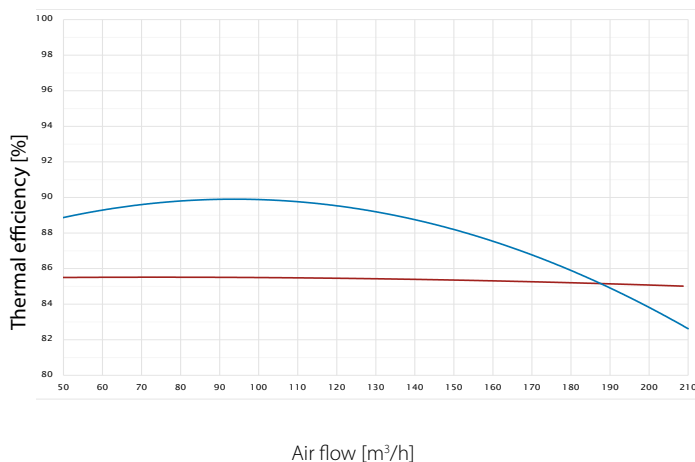

Sounds power level (Lw) – ducts

RPM	Duct	[dB(A)]								
		63Hz	125Hz	250Hz	500Hz	1kHz	2kHz	4kHz	8kHz	Total
1000	supply/exhaust	22.2	23.7	26.3	26.3	23.1	12.7	6.6	18.4	31
	extract/outdoor	23.8	32.1	34.4	38.6	27.9	20.9	9.7	13.0	41
1200	supply/exhaust	24.5	27.3	31.3	30.8	28.5	20.3	20.3	21.9	36
	extract/outdoor	26.4	36.8	38.2	42.3	32.1	27.1	17.7	16.7	45
1400	supply/exhaust	27.3	30.1	35.1	35.6	32.8	26.8	21.4	22.4	40
	extract/outdoor	29.2	38.3	41.5	45.6	35.5	31.6	22.3	21.8	48
1600	supply/exhaust	29.5	31.0	38.9	38.5	35.8	30.1	22.8	22.8	43
	extract/outdoor	32.1	38.5	44.7	49.2	38.6	35.5	26.4	22.0	51
1800	supply/exhaust	31.7	33.0	42.3	41.3	38.7	33.1	23.9	23.2	46
	extract/outdoor	34.1	39.6	48.2	51.4	41.3	38.5	30.0	22.2	54
2000	supply/exhaust	33.8	34.9	47.4	43.6	41.5	35.9	25.3	23.6	50
	extract/outdoor	36.0	41.4	56.1	53.0	43.4	40.8	32.8	22.4	58
2200	supply/exhaust	36.2	36.5	49.3	45.5	44.1	38.6	28.1	24.3	52
	extract/outdoor	38.3	43.4	56.2	54.6	45.7	43.2	35.6	22.7	59
2500	supply/exhaust	39.1	38.9	52.4	48.9	47.2	41.8	31.1	24.7	55
	extract/outdoor	42.2	47.8	57.6	57.4	47.2	44.0	36.4	22.8	61
2900	supply/exhaust	41.6	41.8	55.1	53.4	51.1	45.4	35.7	27.3	59
	extract/outdoor	44.8	50.7	61.0	61.9	51.2	47.8	41.3	25.2	65

Sound pressure level (Lp) – cabinet

RPM	[dB(A)]								
	63Hz	125Hz	250Hz	500Hz	1kHz	2kHz	4kHz	8kHz	Total
1000	5.8	13.6	16.6	22.2	16.6	9.3	7.9	2.9	24
1200	6.4	13.5	20.1	22.4	19.5	11.8	8.3	4.0	26
1400	7.0	17.0	23.8	26.3	24.8	17.9	10.5	4.0	30
1600	8.2	19.4	29.6	28.6	27.0	21.4	20.9	13.7	34
1800	9.2	20.0	34.2	31.5	30.3	25.3	21.1	13.8	38
2000	9.9	21.0	34.6	33.6	32.3	27.5	21.3	6.7	39
2200	10.4	22.1	34.2	35.9	34.4	30.2	21.5	10.2	40
2500	12.6	24.8	36.7	39.1	37.6	33.1	24.2	14.7	43
2900	15.7	27.6	38.3	42.4	40.7	36.8	28.7	20.2	46

RPM	[dB(A)]								
	63Hz	125Hz	250Hz	500Hz	1kHz	2kHz	4kHz	8kHz	Total
1000	5.5	10.1	4.2	22.1	16.5	9.0	7.5	1.6	24
1200	4.2	10.3	13.4	23.2	18.7	11.3	7.9	1.6	25
1400	5.1	13.0	16.6	24.8	21.0	14.0	8.3	2.9	27
1600	5.8	13.9	21.4	28.0	24.6	21.4	20.7	13.5	31
1800	6.4	16.3	29.2	31.0	27.6	24.0	20.7	13.7	35
2000	6.5	17.3	29.3	33.3	30.4	25.3	21.2	13.8	37
2200	8.5	19.2	30.3	35.8	32.1	27.7	21.3	14.0	39
2500	12.2	22.7	31.5	38.5	35.5	30.9	22.3	14.2	41
2900	15.1	25.2	35.2	42.1	38.6	34.7	26.4	17.7	45

Dimensions

On the HCV 300 it is possible to connect the supply duct to the bottom if the ducts are to run beneath the floor.

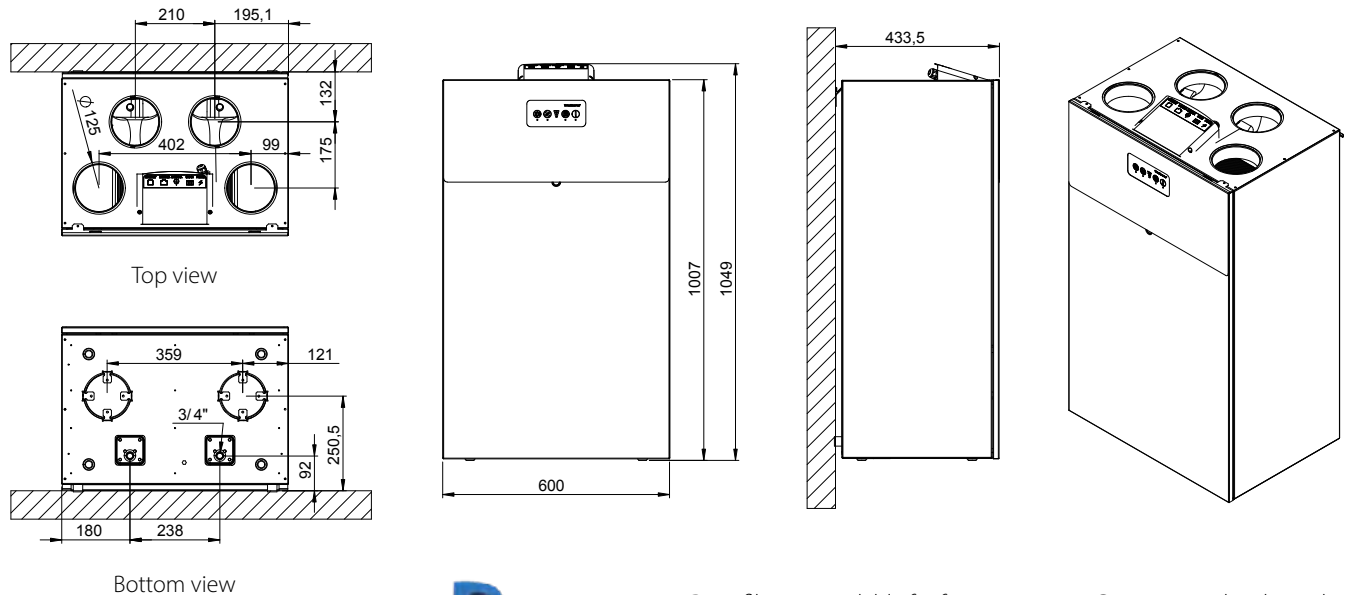

REVIT Revit files are available for free on request. Contact your local supplier or Dantherm for access.

Duct connections

2 set-up in 1 unit, easy change on site

(A) LEFT SET-UP
Factory set-up

(B) RIGHT SET-UP Optional -
easy change on site

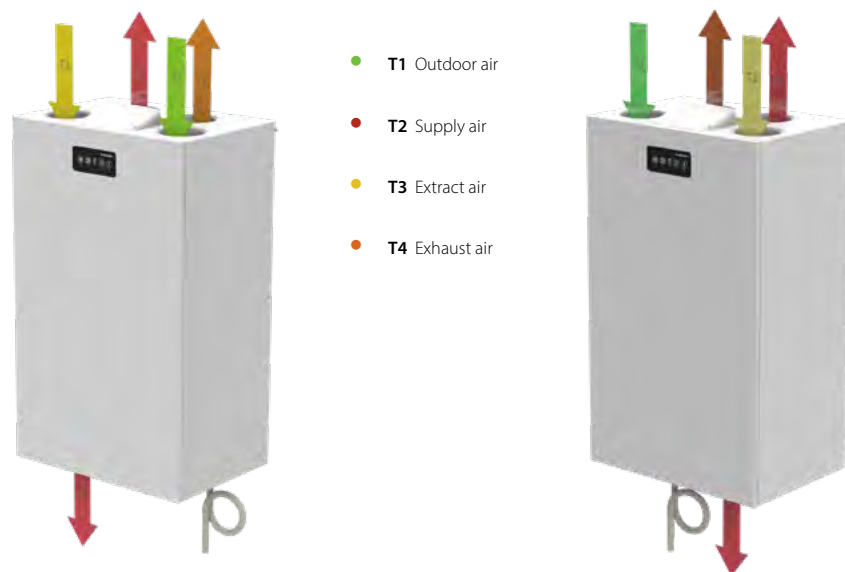



HCV 400P1

The HCV 400P1 is a highly efficient residential ventilation unit for houses, villas, and apartments. It comes supplied as a packaged basic ventilation unit complete with built-in control panel, and is delivered with all parts necessary for wall installation. All HCV 400 units fit perfectly in a 60 x 60cm cupboard.

The HCV 400P1 is either delivered in RAL 9016 cabinet colour and packaged individually one unit on a pallet or in a variant without filter lid and with a galvanised metal surface packaged four units on a pallet to minimise use of packaging in consideration of the environment and to ease handling at building sites.

- Demand-controlled ventilation with integrated humidity sensor, reducing power consumption at times with low ventilation demands
- Summer mode in which the supply fan is stopped and any open window will supply cooler outside air, lowering the room temperature
- Automatic free-cooling features via inbuilt 100% by-pass, including the possibility of increasing the air flow automatically, lets in cool night air following hot days to help maintain a comfortable temperature throughout the day
- Fireplace mode, creating a temporary inside overpressure to enhance chimney functionality
- High-efficiency heat recovery
- EC fan motors with extremely low-energy consumption (low SPI)
- Easy-to-install and commission solution with built-in air pressure spigots for easy calibration
- Highly customisable units with the option to add a high variety of internal as well as external accessories
- Ducts can be connected to the top of the unit, with the option to connect the supply duct to the base if ducts are to run beneath the floor
- The HCV 400 takes up only as little space as a 60 x 60cm cupboard

Third party testing and certification

Code	Description
DIBt Pending	Certified by the German Institute of Construction Technology
PHI	Passivhaus certified
PCDB listed SAP App. Q	Listed in the UK database for balanced whole-house mechanical ventilation with heat recovery
ErP	Compliant with EU regulations for Eco-design
EPB	Listed in the database for Energy Performance of Buildings in Belgium
Nordic Swan Ecolabel	Listed in the Nordic Swan database for products suitable for Ecolabelled buildings
EPD	Environmental product declaration for declared product variant is available in the epddanmark.dk database

Specifications	Units		HCV 400 _{P1}
Maximum achievable flow at 100Pa	V _{100Pa}	m ³ /h	380
Maximum declared flow at 100Pa	V _{max.rated}	m ³ /h	250
Recommended operating range	V	m ³ /h	50-250
EN 13141-7 reference flow at 50Pa	V _{ref}	m ³ /h	175
Performance			
Thermal efficiency in accordance with EN13141-7	η_{SUP}	%	92
Specific power consumption in accordance with EN13141-7	SEL/SYI	W(m ³ /h)	0.23
Leakage (external and internal) in accordance with EN13141-7	-	%	<2% (Class A1)
Filters in accordance with ISO16890	-	-	ISO Coarse 75% (optional on supply: ePM1>50%)
Filters in accordance with EN779	-	-	G4 (optional on supply: F7)
Installation ambient temperature	t _{SURR}	°C	+12 to +50
Outdoor temperature range without preheater installed	t _{ODA}	°C	-12* to +50
Outdoor temperature range with preheater installed	t _{ODA}	°C	-20 to +50
Maximum absolute humidity in extract air	x	g/kg	10
Cabinet			
Dimensions (without wall bracket)	w x d x h	mm	540 x 549 x 1050
Spigots/duct connections	Ø	mm	160 – female
Weight		kg	39
Thermal conductivity – polystyrene insulation	λ	W/mK	0.031
Heat transition figures – polystyrene insulation	U	W/m ² K	<1
Fire classification of the polystyrene insulation	-	-	DIN 4102-1 class B2 EN 13501 class E
Drainage hose	Ø/length	"/m	¾/1
Cabinet colour	RAL	-	9016/galvanised metal grey
Electrical			
Voltage	U	V	230
Maximum power consumption (without/with preheater)	P	W	170/1,570
Frequency	f	Hz	50
Protection class	-	-	IP21

*The use of the preheating coil is recommended at outdoor temperature below -3°C to ensure balanced operation.

Capacity and SPI curves with G4/G4 filters

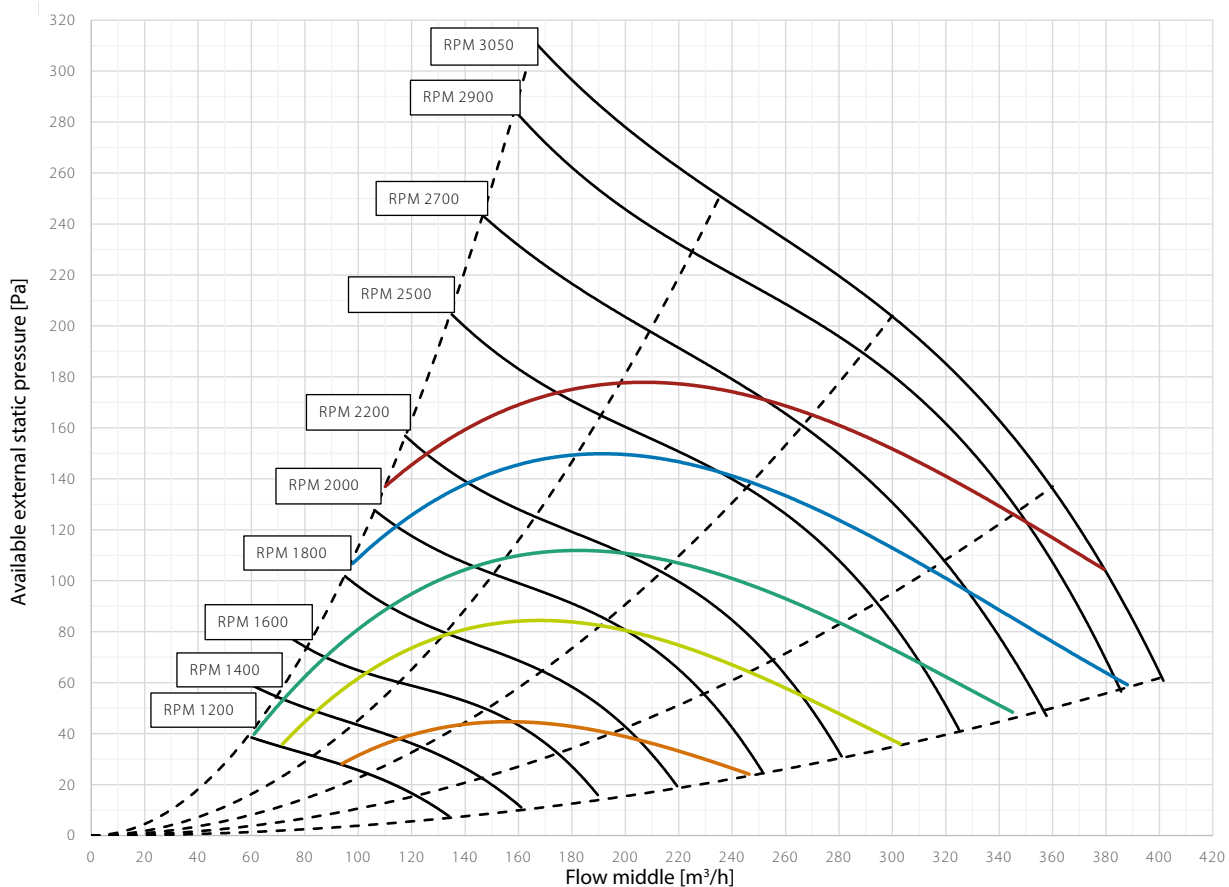

	Red	Blue	Green	Yellow	Orange
SFP/SPI/SEL*	0.45 W/m ³ /h	0.39 W/m ³ /h	0.33 W/m ³ /h	0.28 W/m ³ /h	0.22 W/m ³ /h
	1620 J/m ³	1400 J/m ³	1200 J/m ³	1000 J/m ³	800 J/m ³
	1.62 W/l/s	1.40 W/l/s	1.20 W/l/s	1.0 W/l/s	0.80 W/l/s

* SFP/SPI/SEL includes power consumption of both fans and the control.

Thermal efficiency curves

Legend

- Thermal efficiency according to EN 13141-7 (dry)
Operational conditions: outdoor air: 7°C, 88% RH; extract air: 20°C, 37% RH
- Thermal efficiency according to EN 13141-7 (with condensation)
Operational conditions: outdoor air: 2°C, 84% RH; extract air: 20°C, 60% RH
- Thermal efficiency acc. PassivHaus Institut
Operational conditions: outdoor air: 4°C, 85% RH; extract air: 21°C, 32% RH

All values at balanced flow

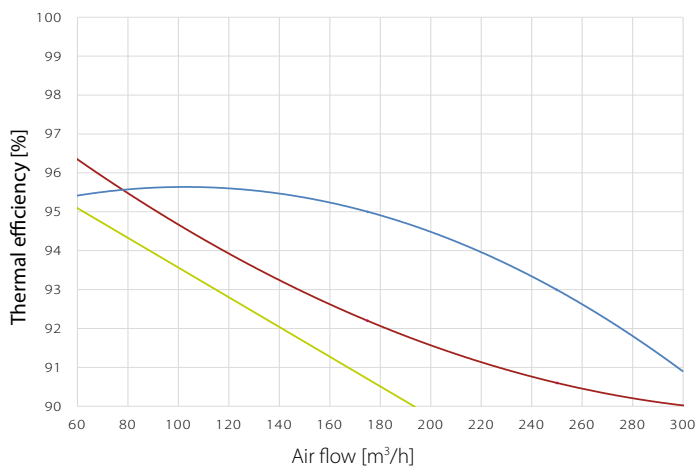

Sound power level (Lw) – ducts

RPM	Duct	[dB(A)]								
		63Hz	125Hz	250Hz	500Hz	1kHz	2kHz	4kHz	8kHz	Total
1200	supply/exhaust	27.9	29.4	30.7	29.7	26.3	23.1	17.5	23.3	36
	extract/outdoor	28.0	38.1	38.1	37.5	30.6	29.4	15.5	13.7	43
1400	supply/exhaust	30.6	30.6	34.8	33.7	29.9	26.8	19.1	23.4	39
	extract/outdoor	30.6	39.3	41.2	41.2	33.7	33.5	20.2	16.4	46
1600	supply/exhaust	32.4	31.2	38.4	37.2	32.9	30.5	20.9	23.8	42
	extract/outdoor	33.3	39.4	46.1	44.8	37.0	37.2	25.1	17.7	50
1800	supply/exhaust	34.6	33.3	44.2	40.7	35.8	33.5	22.9	23.8	47
	extract/outdoor	34.7	40.8	49.1	47.3	39.2	39.2	28.6	18.8	52
2000	supply/exhaust	35.8	34.0	48.8	43.6	38.5	36.2	24.9	24.1	51
	extract/outdoor	36.8	41.9	53.7	48.8	42.0	41.9	31.9	19.6	56
2200	supply/exhaust	37.6	35.0	50.6	46.3	41.0	38.7	28.2	24.8	53
	extract/outdoor	38.4	43.0	55.2	50.1	44.0	43.8	34.3	24.3	57
2500	supply/exhaust	40.5	36.8	53.5	48.5	44.4	41.9	31.3	25.4	55
	extract/outdoor	41.3	45.4	58.6	53.9	47.5	47.1	38.2	31.0	60
2700	supply/exhaust	41.9	38.9	54.4	50.2	46.4	43.7	33.7	27.7	57
	extract/outdoor	42.8	47.2	60.7	57.7	49.6	48.9	40.4	33.6	63
2900	supply/exhaust	43.4	40.3	54.4	52.5	48.7	45.5	35.7	29.2	58
	extract/outdoor	44.4	48.8	60.1	61.7	51.7	50.6	42.0	35.5	65

Sound pressure level (Lp) – cabinet**1m distance**

RPM	[dB(A)]								
	63Hz	125Hz	250Hz	500Hz	1kHz	2kHz	4kHz	8kHz	Total
1200	-	-	12.9	19.5	21.5	21.9	18.0	10.3	27
1400	-	5.7	18.5	23.8	23.5	23.5	18.5	10.6	29
1600	-	6.0	22.1	26.9	26.3	27.6	18.8	11.0	32
1800	-	6.9	25.3	29.4	28.2	28.3	20.6	12.0	34
2000	-	7.6	27.8	31.2	30.7	30.5	22.6	14.3	36
2200	-	8.0	31.3	33.3	32.6	32.8	24.8	17.4	39
2600	-	10.5	31.3	38.2	37.0	36.9	29.7	22.8	43
3000	-	13.1	31.4	43.1	40.2	40.0	33.0	26.1	47
3400	-	16.7	33.8	49.7	44.5	43.3	36.5	29.8	52

2m distance

RPM	[dB(A)]								
	63Hz	125Hz	250Hz	500Hz	1kHz	2kHz	4kHz	8kHz	Total
1200	-	-	8.7	18.6	21.5	21.9	18.0	10.3	27
1400	-	-	12.7	22.1	22.8	22.8	18.5	10.6	28
1600	-	-	16.9	25.3	25.5	24.9	18.8	11.0	31
1800	-	2.1	20.0	28.6	27.2	26.4	20.6	12.0	33
2000	-	3.5	22.9	30.9	29.4	28.5	21.7	13.6	35
2200	-	5.0	26.4	32.6	31.4	30.1	23.2	15.3	37
2600	-	8.1	27.3	37.2	36.3	33.8	27.1	19.9	41
3000	-	11.0	30.0	43.1	39.1	37.2	30.7	23.6	46
3400	-	14.0	30.9	49.7	42.7	41.6	34.1	27.1	51

Dimensions

On the HCV 400 it is possible to connect the supply duct to the bottom if the ducts are to run beneath the floor.

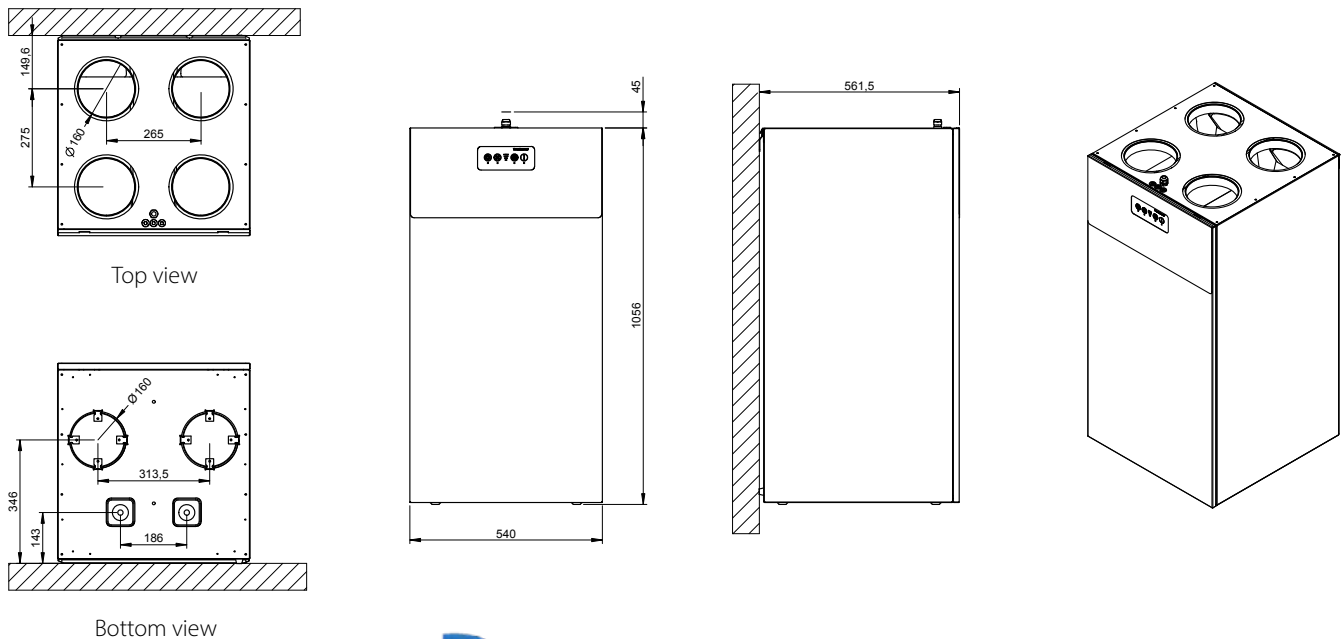

Revit files are available for free on request. Contact your local supplier or Dantherm for access.

Duct connections

2 set-up in 1 unit, easy change on site



HCV 400P2



HCV 400P2

The HCV 400P2 is a highly efficient residential ventilation unit for houses, villas, and apartments. It comes supplied as a packaged basic ventilation unit complete with built-in control panel, and is delivered with all parts necessary for wall installation. All HCV 400 units fit perfectly in a 60 x 60cm cupboard.

The HCV 400P2 is either delivered in RAL 9016 cabinet colour and packaged individually one unit on a pallet or in a variant without filter lid and with a galvanised metal surface packaged four units on a pallet to minimise use of packaging in consideration of the environment and to ease handling at building sites.

- Demand-controlled ventilation with integrated humidity sensor, reducing power consumption at times with low ventilation demands
- Summer mode in which the supply fan is stopped and any open window will supply cooler outside air, lowering the room temperature
- Automatic free-cooling features via inbuilt 100% by-pass, including the possibility of increasing the air flow automatically, lets in cool night air following hot days to help maintain a comfortable temperature throughout the day
- Fireplace mode, creating a temporary inside overpressure to enhance chimney functionality
- High-efficiency heat recovery
- EC fan motors with extremely low-energy consumption (low SPI)
- Easy-to-install and commission solution with built-in air pressure spigots for easy calibration
- Highly customisable units with the option to add a high variety of internal as well as external accessories
- Ducts can be connected to the top of the unit, with the option to connect the supply duct to the base if ducts are to run beneath the floor
- The HCV 400 takes up only as little space as a 60 x 60cm cupboard

Third party testing and certifications

Code	Description
ErP	Compliant with EU regulations for Eco-design
Nordic Swan Ecolabel	Listed in the Nordic Swan database for products suitable for Ecolabelled buildings
EPD	Environmental product declaration for declared product variant is available in the epddanmark.dk database

Specifications	Units		HCV 400 _{P2}
Maximum achievable flow at 100Pa	V100Pa	m ³ /h	330
Maximum declared flow at 100Pa	V _{max.rated}	m ³ /h	240
Recommended operating range	V	m ³ /h	50-240
EN 13141-7 reference flow at 50Pa	V _{ref}	m ³ /h	168
Performance			
Thermal efficiency in accordance with EN13141-7	η_{SUP}	%	91
Specific power consumption in accordance with EN13141-7	SEL/SYI	W(m ³ /h)	0.20
Leakage (external and internal) in accordance with EN13141-7	-	%	<2% (Class A1)
Filters in accordance with ISO16890	-	-	ISO Coarse 75% (optional on supply: ePM1>50%)
Filters in accordance with EN779	-	-	G4 (optional on supply: F7)
Installation ambient temperature	t _{SURR}	°C	+12 to +50
Outdoor temperature range without preheater installed	t _{ODA}	°C	-12* to +50
Outdoor temperature range with preheater installed	t _{ODA}	°C	-20 to +50
Maximum absolute humidity in extract air	x	g/kg	10
Cabinet			
Dimensions (without wall bracket)	w x d x h	mm	540 x 549 x 1050
Spigots/duct connections	Ø	mm	160 – female
Weight		kg	39
Thermal conductivity – polystyrene insulation	λ	W/mK	0.031
Heat transition figures – polystyrene insulation	U	W/m ² K	<1
Fire classification of the polystyrene insulation	-	-	DIN 4102-1 class B2 EN 13501 class E
Drainage hose	Ø/length	"/m	¾/1
Cabinet colour	RAL	-	9016/galvanised metal grey
Electrical			
Voltage	U	V	230
Maximum power consumption (without/with preheater)	P	W	170/1,570
Frequency	f	Hz	50
Protection class	-	-	IP21

*The use of the preheating coil is recommended at outdoor temperature below -3°C to ensure balanced operation.

Capacity and SPI curves with G4/G4 filters

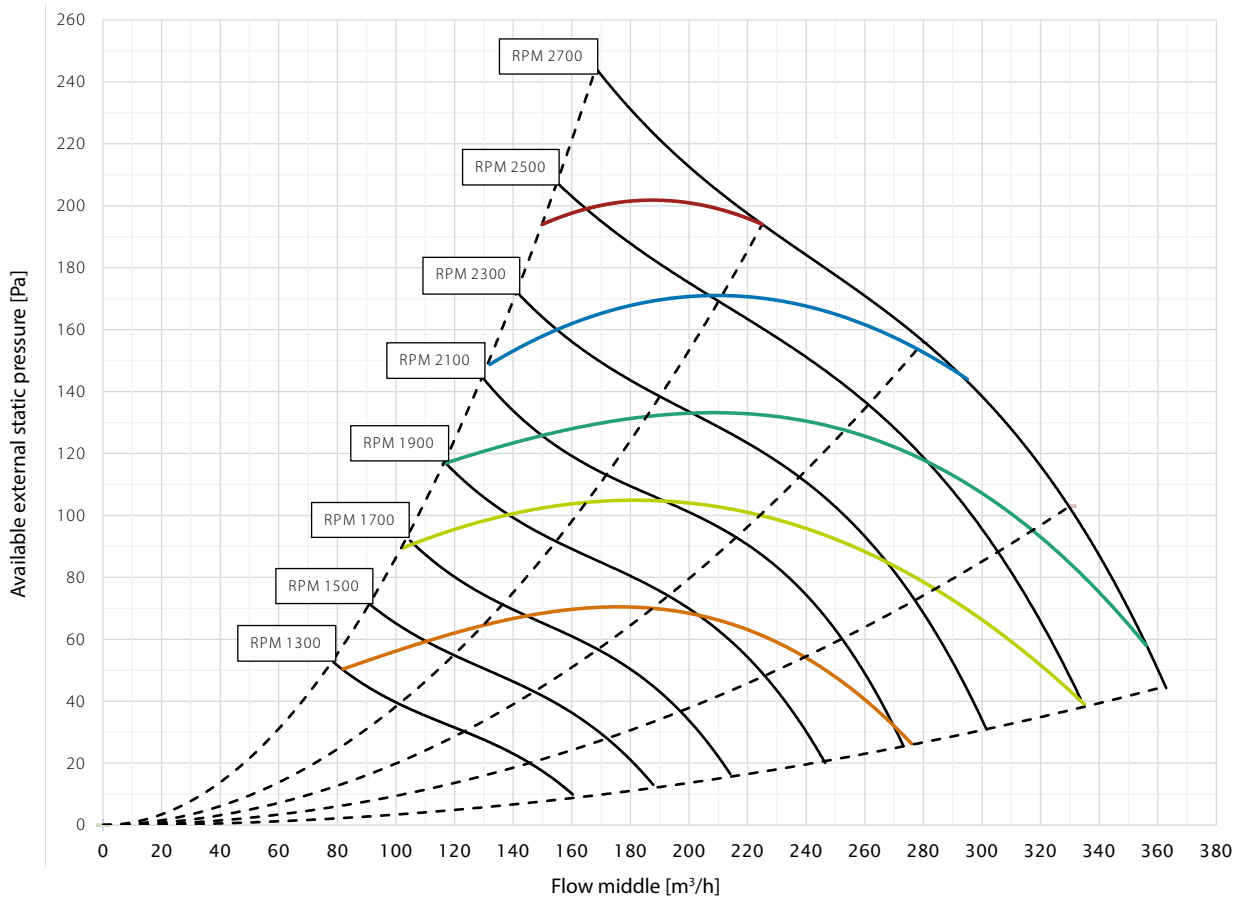

	—	—	—	—	—
SFP/SPI/SEL*	0.45 W/m ³ /h	0.39 W/m ³ /h	0.33 W/m ³ /h	0.28 W/m ³ /h	0.22 W/m ³ /h
	1620 J/m ³	1400 J/m ³	1200 J/m ³	1000 J/m ³	800 J/m ³
	1.62 W/l/s	1.40 W/l/s	1.20 W/l/s	1.0 W/l/s	0.80 W/l/s

* SFP/SPI/SEL includes power consumption of both fans and the control.

Thermal efficiency curves

Legend

- Thermal efficiency according to EN 13141-7 (dry)
Operational conditions: outdoor air: 7°C, 85% RH; extract air: 20°C, 37% RH
- Thermal efficiency according to EN 13141-7 (with condensation)
Operational conditions: outdoor air: 2°C, 85% RH; extract air: 20°C, 60% RH
- Thermal efficiency acc. PassivHaus Institut
Operational conditions: outdoor air: 4°C, 80% RH; extract air: 21°C, 30% RH

All values at balanced flow

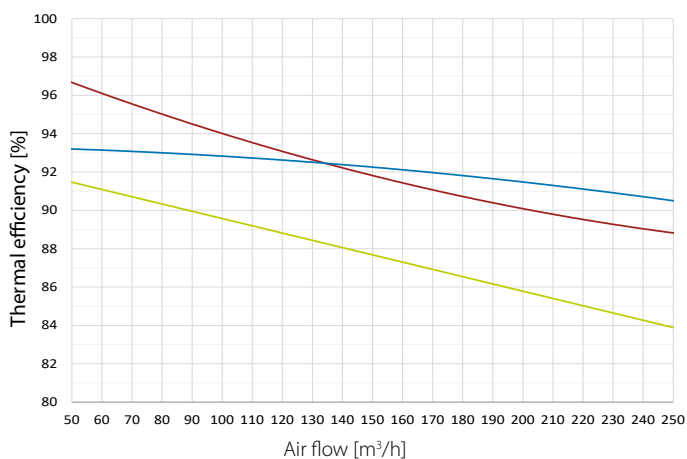

Sound power level (Lw) – ducts

RPM	Duct	[dB(A)]								
		63Hz	125Hz	250Hz	500Hz	1kHz	2kHz	4kHz	8kHz	Total
1200	supply/exhaust	26.9	29.6	30.6	30.6	25.8	23.0	11.7	16.4	36
	extract/outdoor	28.0	38.1	38.1	37.5	30.6	29.4	15.5	13.7	43
1300	supply/exhaust	28.8	30.1	32.5	32.4	27.5	24.6	14.5	17.9	37
	extract/outdoor	29.4	39.7	39.8	39.5	32.3	31.7	19.0	16.4	45
1400	supply/exhaust	29.7	30.5	34.4	34.5	29.4	27.1	16.6	19.6	39
	extract/outdoor	30.6	39.3	41.2	41.2	33.7	33.5	20.2	17.7	46
1500	supply/exhaust	31.1	31.3	37.0	36.5	31.3	29.3	18.2	21.0	41
	extract/outdoor	31.8	39.0	43.5	43.1	35.4	35.3	22.3	18.8	48
1600	supply/exhaust	31.9	32.0	38.6	38.0	32.8	31.1	20.3	21.6	43
	extract/outdoor	33.3	38.7	46.1	44.8	37.0	37.2	25.1	19.6	49
1700	supply/exhaust	32.5	32.5	41.6	39.7	34.2	32.6	20.9	22.1	45
	extract/outdoor	34.0	39.2	48.8	46.1	38.3	38.7	26.6	20.4	51
1800	supply/exhaust	32.0	31.1	42.4	41.4	35.9	34.5	22.7	22.6	46
	extract/outdoor	35.2	39.7	52.0	47.2	39.8	40.1	28.7	21.0	54
1900	supply/exhaust	33.1	32.3	43.7	42.8	37.3	36.1	24.6	23.0	47
	extract/outdoor	35.9	40.1	52.4	47.9	40.7	41.2	30.1	21.7	54
2000	supply/exhaust	34.0	33.1	45.3	43.5	38.5	37.2	25.4	23.4	49
	extract/outdoor	37.2	40.8	55.2	48.3	42.1	42.6	31.7	22.6	57
2100	supply/exhaust	34.9	33.6	46.6	44.4	39.8	38.4	26.7	23.8	50
	extract/outdoor	38.1	41.6	56.0	49.2	43.3	43.7	33.2	24.6	57
2200	supply/exhaust	36.7	35.4	48.3	45.4	41.3	39.8	28.6	24.1	51
	extract/outdoor	38.5	42.7	58.5	50.3	44.6	44.9	34.7	27.0	59
2300	supply/exhaust	37.2	36.2	50.9	46.7	42.6	41.0	30.2	24.5	53
	extract/outdoor	39.4	43.3	60.8	51.4	45.4	45.7	35.7	27.8	62
2400	supply/exhaust	38.2	37.0	51.1	47.9	43.6	42.1	31.6	24.7	54
	extract/outdoor	40.4	44.1	60.0	52.7	46.6	46.8	37.0	29.5	61
2500	supply/exhaust	39.3	37.7	51.7	48.9	44.6	43.0	32.7	25.6	55
	extract/outdoor	41.1	45.0	59.3	54.4	47.5	47.7	38.2	30.8	61
2600	supply/exhaust	40.8	38.6	52.3	50.3	45.7	44.0	33.9	27.3	55
	extract/outdoor	42.3	45.5	60.5	56.3	48.6	48.7	39.2	32.2	62
2700	supply/exhaust	40.8	39.3	53.0	51.9	46.6	44.8	34.9	27.6	56
	extract/outdoor	42.4	46.3	62.3	58.3	49.6	49.4	40.1	33.1	64

Sound pressure level (Lp) – cabinet**1m distance**

RPM	[dB(A)]								
	63Hz	125Hz	250Hz	500Hz	1kHz	2kHz	4kHz	8kHz	Total
1200	-	-	12.9	19.5	21.5	21.9	18.0	10.3	27
1400	-	5.7	18.5	23.8	23.5	23.5	18.5	10.6	29
1600	-	6.0	22.1	26.9	26.3	27.6	18.8	11.0	32
1800	-	6.9	25.3	29.4	28.2	28.3	20.6	12.0	34
2000	-	7.6	27.8	31.2	30.7	30.5	22.6	14.3	36
2200	-	8.0	31.3	33.3	32.6	32.8	24.8	17.4	39
2600	-	10.5	31.3	38.2	37.0	36.9	29.7	22.8	43
3000	-	13.1	31.4	43.1	40.2	40.0	33.0	26.1	47
3400	-	16.7	33.8	49.7	44.5	43.3	36.5	29.8	52

2m distance

RPM	[dB(A)]								
	63Hz	125Hz	250Hz	500Hz	1kHz	2kHz	4kHz	8kHz	Total
1200	-	-	8.7	18.6	21.5	21.9	18.0	10.3	27
1400	-	-	12.7	22.1	22.8	22.8	18.5	10.6	28
1600	-	-	16.9	25.3	25.5	24.9	18.8	11.0	31
1800	-	2.1	20.0	28.6	27.2	26.4	20.6	12.0	33
2000	-	3.5	22.9	30.9	29.4	28.5	21.7	13.6	35
2200	-	5.0	26.4	32.6	31.4	30.1	23.2	15.3	37
2600	-	8.1	27.3	37.2	36.3	33.8	27.1	19.9	41
3000	-	11.0	30.0	43.1	39.1	37.2	30.7	23.6	46
3400	-	14.0	30.9	49.7	42.7	41.6	34.1	27.1	51

Dimensions

On the HCV 400 it is possible to connect the supply duct to the bottom if the ducts are to run beneath the floor.

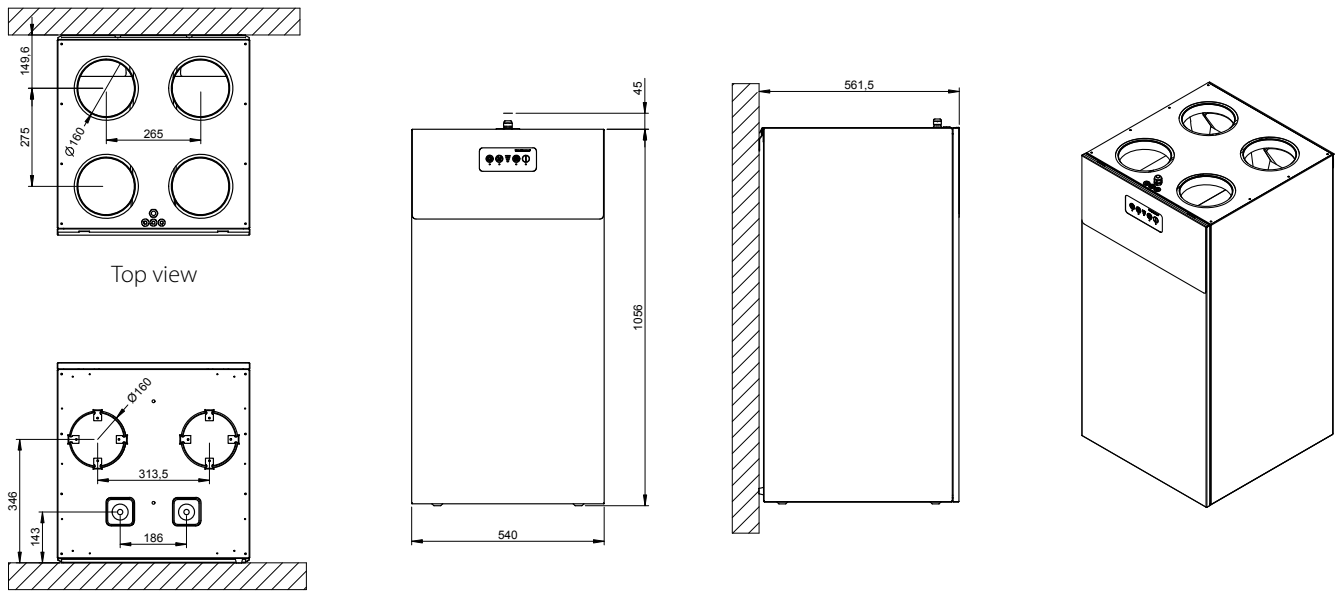

Bottom view



Revit files are available for free on request. Contact your local supplier or Dantherm for access.

Duct connections

2 set-up in 1 unit, easy change on site

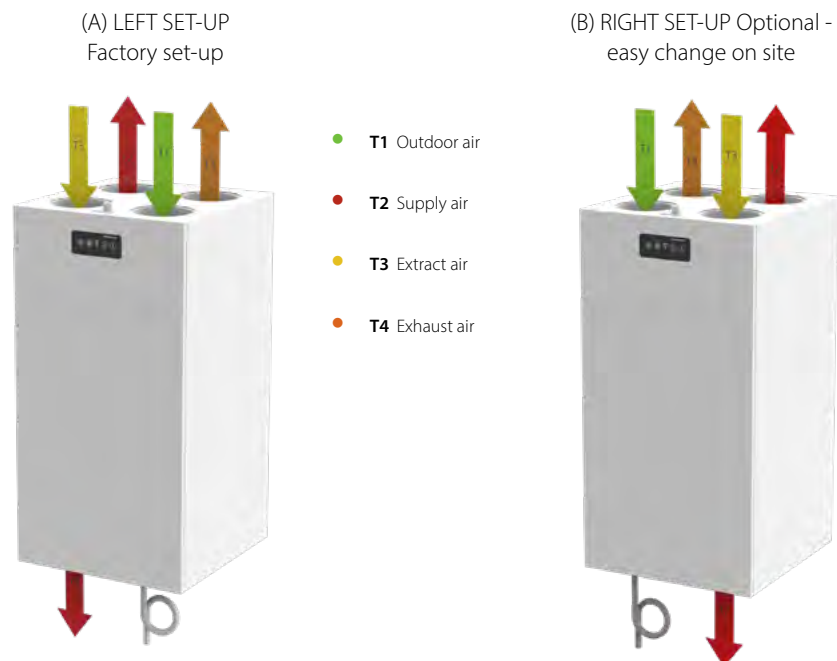



HCV 400_{E1}

The HCV 400_{E1} is a highly efficient residential ventilation unit for houses, villas, and apartments. It comes supplied as a packaged basic ventilation unit complete with built-in control panel, and is delivered with all parts necessary for wall installation. All HCV 400 units fit perfectly in a 60 x 60cm cupboard.

The HCV 400_{E1} is delivered in RAL 9016 cabinet colour and packaged individually one unit on a pallet.

- Demand-controlled ventilation with integrated humidity sensor, reducing power consumption at times with low ventilation demands
- Summer mode in which supply fan is stopped and any open window will supply cooler outside air, lowering the room temperature
- Automatic free-cooling features via inbuilt 100% by-pass, including the possibility of increasing the air flow automatically, lets in cool night air following hot days to help maintain a comfortable temperature throughout the day
- Fireplace mode, creating a temporary inside overpressure to enhance chimney functionality
- High-efficiency heat recovery
- EC fan motors with extremely low energy consumption (low SPI)
- Easy-to-install and commission solution with built-in air pressure spigots for easy calibration
- Highly customisable units, with the option to add a high variety of internal as well as external accessories
- Ducts can be connected to the top of the unit, with the option to connect the supply duct to the base if ducts are to run beneath the floor
- The HCV 400 takes up only as little space as a 60 x 60cm cupboard

Third party testing and certifications

Code	Description
ErP	Compliant with EU regulations for Eco-design
Nordic Swan Ecolabel	Listed in the Nordic Swan database for products suitable for Ecolabelled buildings
EPD	Environmental product declaration for declared product variant is available in the epddanmark.dk database

Specifications	Units		HCV 400 _{E1}
Maximum achievable flow at 100Pa	V100Pa	m ³ /h	330
Maximum declared flow at 100Pa	V _{max.rated}	m ³ /h	240
Recommended operating range	V	m ³ /h	50-240
EN 13141-7 reference flow at 50Pa	V _{ref}	m ³ /h	168
Performance			
Thermal efficiency in accordance with EN13141-7	η_{SUP}	%	84
Specific power consumption in accordance with EN13141-7	SEL/SYI	W(m ³ /h)	0.20
Leakage (external and internal) in accordance with EN13141-7	-	%	<2% (Class A1)
Filters in accordance with ISO16890	-	-	ISO Coarse 75% (optional on supply: ePM1>50%)
Filters in accordance with EN779	-	-	G4 (optional on supply: F7)
Installation ambient temperature	t _{SURR}	°C	+12 to +50
Outdoor temperature range without preheater installed	t _{ODA}	°C	-12* to +50
Outdoor temperature range with preheater installed	t _{ODA}	°C	-20 to +50
Maximum absolute humidity in extract air	x	g/kg	10
Cabinet			
External dimensions (without wall bracket)	w x d x h	mm	540 x 549 x 1050
Spigots/duct connections	Ø	mm	160 – female
Weight		kg	39
Thermal conductivity – polystyrene insulation	λ	W/mK	0.031
Heat transition figures – polystyrene insulation	U	W/m ² K	<1
Fire classification of the polystyrene insulation	-	-	DIN 4102-1 class B2 EN 13501 class E
Drainage hose	Ø/length	"/m	¾/1
Cabinet colour	RAL	-	9016
Electrical			
Voltage	U	V	230
Maximum power consumption (without/with preheater)	P	W	170/1,570
Frequency	f	Hz	50
Protection class	-	-	IP21

*The use of the preheating coil is recommended at outdoor temperature below -5°C to ensure balanced operation.

Capacity and SPI curves with G4/G4 filters

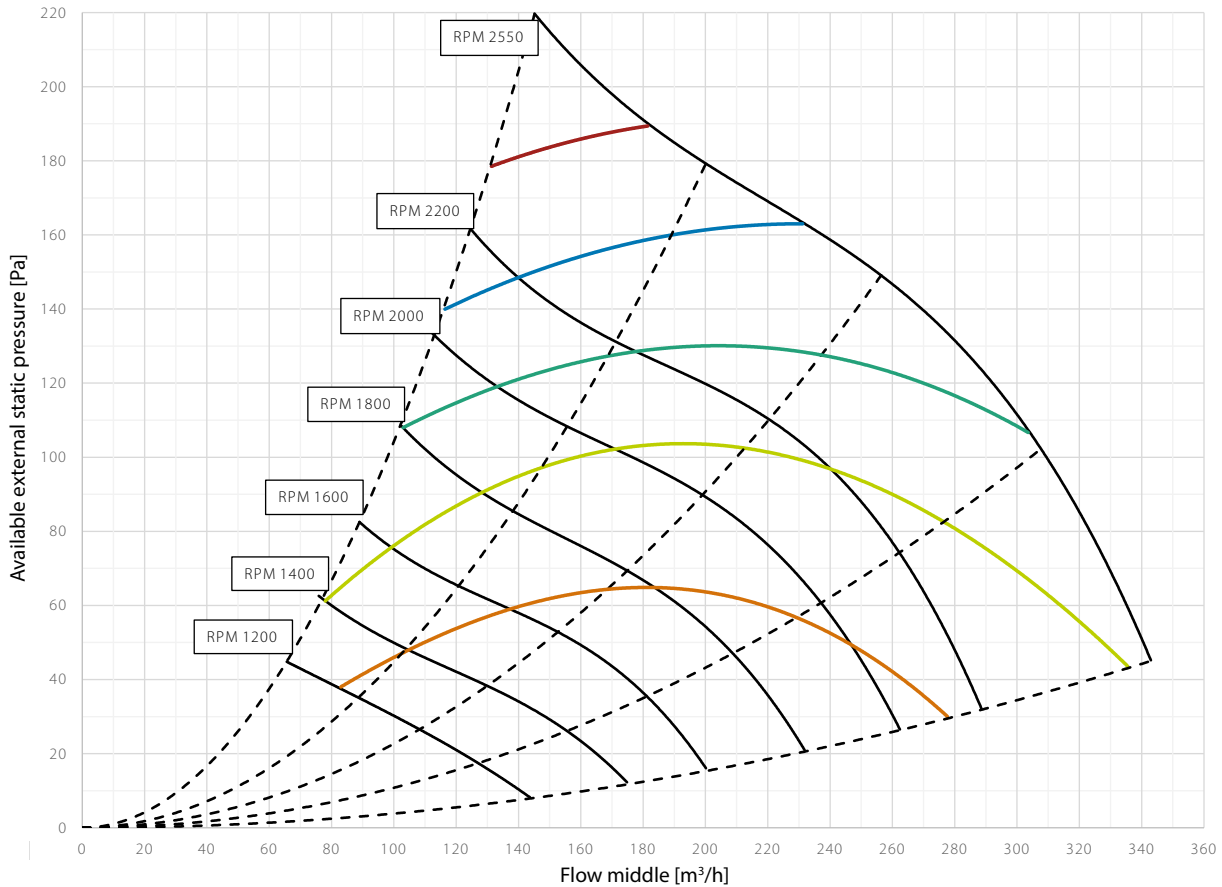

SFP/SPI/SEL*	0.45 W/m ³ /h	0.39 W/m ³ /h	0.33 W/m ³ /h	0.28 W/m ³ /h	0.22 W/m ³ /h
	1620 J/m ³	1400 J/m ³	1200 J/m ³	1000 J/m ³	800 J/m ³
	1.62 W/l/s	1.40 W/l/s	1.20 W/l/s	1.0 W/l/s	0.80 W/l/s

* SFP/SPI/SEL includes power consumption of both fans and the control.

Thermal efficiency curves

Legend

- Thermal efficiency according to EN 13141-7 (dry)
Operational conditions: outdoor air: 7°C, 70% RH; extract air: 20°C, 38% RH
- Humidity efficiency acc. to EN 13141-7 (with condensation)
Operational conditions: outdoor air: 2°C, 88% RH; extract air: 20°C, 60% RH

All values at balanced flow

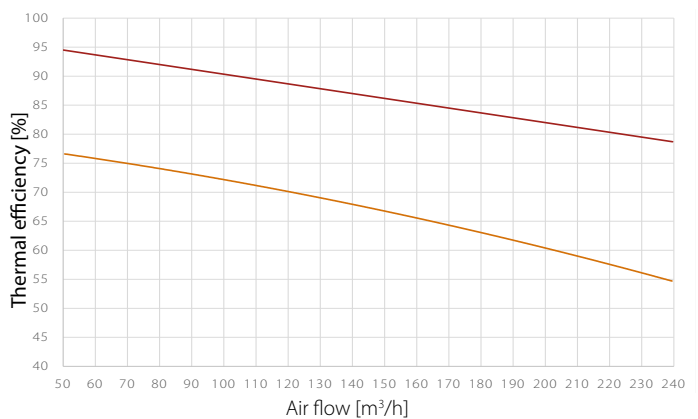

Sound power level (L_w) – ducts

RPM	Duct	[dB(A)]								
		63Hz	125Hz	250Hz	500Hz	1kHz	2kHz	4kHz	8kHz	Total
1200	supply/exhaust	28.6	31.3	32.3	32.3	26.8	23.0	11.7	14.5	37
	extract/outdoor	28.0	38.1	38.1	37.5	30.6	29.4	15.5	16.4	43
1300	supply/exhaust	30.5	31.8	34.2	34.1	28.5	24.6	14.5	17.9	39
	extract/outdoor	29.4	39.7	39.8	39.5	32.3	31.7	19.0	19.0	45
1400	supply/exhaust	31.4	32.2	36.1	36.2	30.4	27.1	16.6	18.3	41
	extract/outdoor	30.6	39.3	41.2	41.2	33.7	33.5	20.2	20.4	46
1500	supply/exhaust	32.8	33.0	38.7	38.2	32.3	29.3	18.2	19.6	43
	extract/outdoor	31.8	39.0	43.5	43.1	35.4	35.3	22.3	21.6	48
1600	supply/exhaust	33.6	33.7	40.3	39.7	33.8	31.1	20.3	20.4	44
	extract/outdoor	33.3	38.7	46.1	44.8	37.0	37.2	25.1	22.1	49
1700	supply/exhaust	34.2	34.2	43.3	41.4	35.2	32.6	20.9	21.0	46
	extract/outdoor	34.0	39.2	48.8	46.1	38.3	38.7	26.6	22.6	51
1800	supply/exhaust	33.7	32.8	44.1	43.1	36.9	34.5	22.7	21.6	47
	extract/outdoor	35.2	39.7	52.0	47.2	39.8	40.1	28.7	23.0	54
1900	supply/exhaust	34.8	34.0	45.4	44.5	38.3	36.1	24.6	22.1	49
	extract/outdoor	35.9	40.1	52.4	47.9	40.7	41.2	30.1	23.4	54
2000	supply/exhaust	35.7	34.8	47.0	45.2	39.5	37.2	25.4	23.0	50
	extract/outdoor	37.2	40.8	55.2	48.3	42.1	42.6	31.7	23.8	57
2100	supply/exhaust	36.6	35.3	48.3	46.1	40.8	38.4	26.7	23.8	51
	extract/outdoor	38.1	41.6	56.0	49.2	43.3	43.7	33.2	24.6	57
2200	supply/exhaust	38.4	37.1	50.0	47.1	42.3	39.8	28.6	24.1	53
	extract/outdoor	38.5	42.7	58.5	50.3	44.6	44.9	34.7	27.0	59
2300	supply/exhaust	38.9	37.9	52.6	48.4	43.6	41.0	30.2	24.5	55
	extract/outdoor	39.4	43.3	60.8	51.4	45.4	45.7	35.7	27.8	62
2400	supply/exhaust	39.9	38.7	52.8	49.6	44.6	42.1	31.6	24.7	55
	extract/outdoor	40.4	44.1	60.0	52.7	46.6	46.8	37.0	29.5	61
2500	supply/exhaust	41.0	39.4	53.4	50.6	45.6	43.0	32.7	25.6	56
	extract/outdoor	41.1	45.0	59.3	54.4	47.5	47.7	38.2	30.8	61
2600	supply/exhaust	42.5	40.3	54.0	52.0	46.7	44.0	33.9	27.3	57
	extract/outdoor	42.3	45.5	60.5	56.3	48.6	48.7	39.2	32.2	62
2700	supply/exhaust	42.5	41.0	54.7	53.6	47.6	44.8	34.9	27.6	58
	extract/outdoor	42.4	46.3	62.3	58.3	49.6	49.4	40.1	33.1	64

Sound pressure level (Lp) – cabinet**1m distance**

	[dB(A)]								
RPM	63Hz	125Hz	250Hz	500Hz	1kHz	2kHz	4kHz	8kHz	Total
1200	-	-	12.9	19.5	21.5	21.9	18.0	10.3	27
1400	-	5.7	18.5	23.8	23.5	23.5	18.5	10.6	29
1600	-	6.0	22.1	26.9	26.3	27.6	18.8	11.0	32
1800	-	6.9	25.3	29.4	28.2	28.3	20.6	12.0	34
2000	-	7.6	27.8	31.2	30.7	30.5	22.6	14.3	36
2200	-	8.0	31.3	33.3	32.6	32.8	24.8	17.4	39
2600	-	10.5	31.3	38.2	37.0	36.9	29.7	22.8	43
3000	-	13.1	31.4	43.1	40.2	40.0	33.0	26.1	47
3400	-	16.7	33.8	49.7	44.5	43.3	36.5	29.8	52

2m distance

	[dB(A)]								
RPM	63Hz	125Hz	250Hz	500Hz	1kHz	2kHz	4kHz	8kHz	Total
1200	-	-	8.7	18.6	21.5	21.9	18.0	10.3	27
1400	-	-	12.7	22.1	22.8	22.8	18.5	10.6	28
1600	-	-	16.9	25.3	25.5	24.9	18.8	11.0	31
1800	-	2.1	20.0	28.6	27.2	26.4	20.6	12.0	33
2000	-	3.5	22.9	30.9	29.4	28.5	21.7	13.6	35
2200	-	5.0	26.4	32.6	31.4	30.1	23.2	15.3	37
2600	-	8.1	27.3	37.2	36.3	33.8	27.1	19.9	41
3000	-	11.0	30.0	43.1	39.1	37.2	30.7	23.6	46
3400	-	14.0	30.9	49.7	42.7	41.6	34.1	27.1	51

Dimensions

On the HCV 400 it is possible to connect the supply duct to the bottom if the ducts are to run beneath the floor.

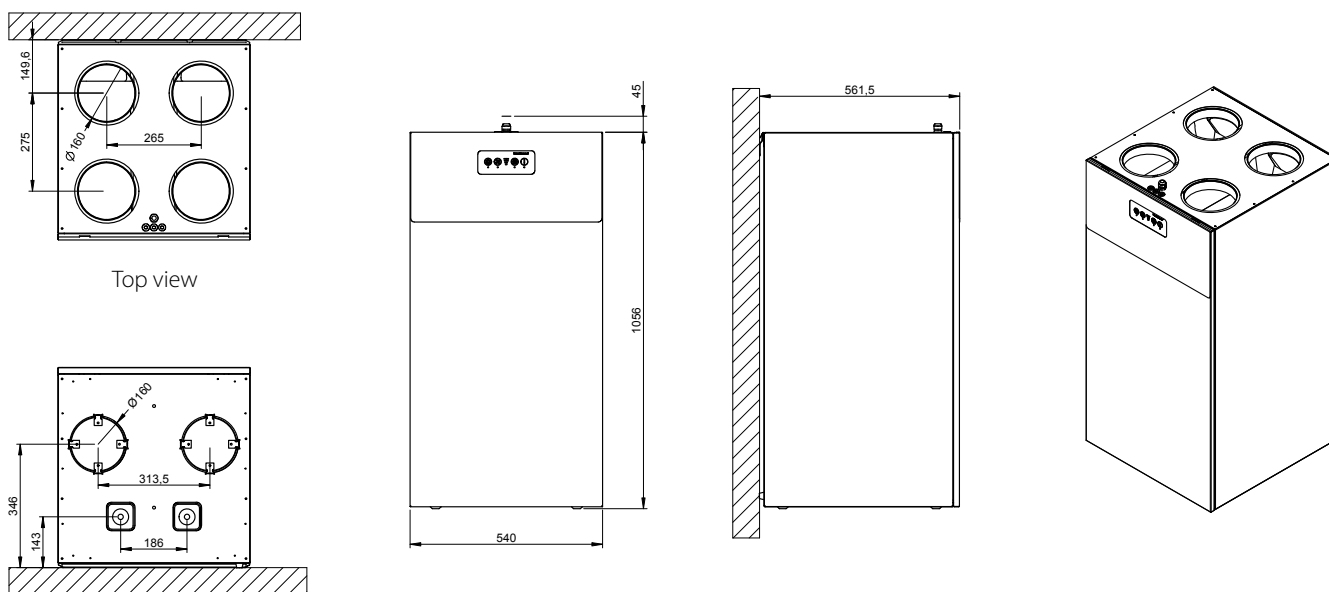

Top view

Bottom view



Revit files are available for free on request. Contact your local supplier or Dantherm for access.

Duct connections

2 set-up in 1 unit, easy change on site



HCV 460_{P2}



HCV 460_{P2}

The HCV 460_{P2} is a highly efficient residential ventilation unit for houses, villas, and apartments. It comes supplied as a packaged basic ventilation unit complete with built-in control panel, and is delivered with all parts necessary for wall installation. All HCV 460 units also fit perfectly in a 60 x 60cm cupboard.

The HCV 460_{P2} is either delivered in RAL 9016 cabinet colour and packaged individually one unit on a pallet or in a variant without filter lid and with a galvanised metal surface packaged four units on a pallet to minimise use of packaging in consideration of the environment and to ease handling at building sites.



- Demand-controlled ventilation with integrated humidity sensor, reducing power consumption at times with low ventilation demands
- Summer mode in which supply fan is stopped and any open window will supply cooler outside air, lowering the room temperature
- Automatic free-cooling features via inbuilt 100% by-pass, including the possibility of increasing the air flow automatically, lets in cool night air following hot days to help maintain a comfortable temperature throughout the day
- Fireplace mode, creating a temporary inside overpressure to enhance chimney functionality
- High-efficiency heat recovery
- EC fan motors with extremely low energy consumption (low SPI)
- Easy-to-install and commission solution with built-in air pressure spigots for easy calibration
- Highly customisable units with the option to add a high variety of internal as well as external accessories
- The HCV 460 takes up only as little space as a 60 x 60cm cupboard

Third party testing and certifications

Code	Description
PHI	Passivhaus certified
DIBt Pending	Certified by the German Institute of Construction Technology
PCDB listed SAP App. Q	Listed in the UK database for balanced whole-house mechanical ventilation with heat recovery
ErP	Compliant with EU regulations for Eco-design
Nordic Swan Ecolabel	Listed in the Nordic Swan database for products suitable for Ecolabelled buildings
EPD	Environmental product declaration for declared product variant is available in the epddanmark.dk database

Specifications	Units		HCV 460 _{P2}
Maximum achievable flow at 100Pa	V _{100Pa}	m ³ /h	460
Maximum declared flow at 100Pa	V _{maxrated}	m ³ /h	360
Operating range DIBt	V _{DIBt}	m ³ /h	70-360
Operating range Passivhaus at 100Pa	V _{phi}	m ³ /h	106-270
EN 13141-7 reference flow at 50Pa	V _{ref}	m ³ /h	252
Performance			
Thermal efficiency in accordance with EN13141-7	η _{SUP}	%	86
Leakage (external and internal) in accordance with EN 13141-7			<2% (Class A1)
Filters in accordance with ISO16890	-	-	ISO Coarse 75% (optional on supply: ePM1>50%)
Filters in accordance with EN779			G4 (optional on supply: F7)
Installation surrounding temperature	t _{SURR}	°C	+12 to +50
Outdoor temperature without preheater installed	t _{ODA}	°C	-12* to +50
Outdoor temperature with preheater installed	t _{ODA}	°C	-20 to +50
Maximum absolute humidity of extract air	x	g/kg	10
Cabinet			
Dimensions (without bracket)	w x h x d	mm	540 x 549 x 1050**
Spigots/ducts connections	∅	mm	160 – female
Weight		kg	40
Thermal conductivity – polystyrene insulation	λ	W/mK	0.031
Heat transition figures – polystyrene insulation	U	W/m ² K	U<1
Fire classification of the polystyrene insulation	-	-	DIN 4102-1 class B2 EN 13501 class E
Drainage hose included	∅/length	"/m	¾/1
Cabinet colour	RAL	-	9016/galvanised metal grey
Electrical			
Voltage	U	V	230
Maximum power consumption (without/with preheater)	P	W	230/2,080
Frequency	f	Hz	50
Protection class	-	-	IP21

* The use of preheating coil is recommended at outdoor temperature -3°C to ensure balanced operation.

** +20mm fitting.

Capacity and SPI curves with G4/G4 filters

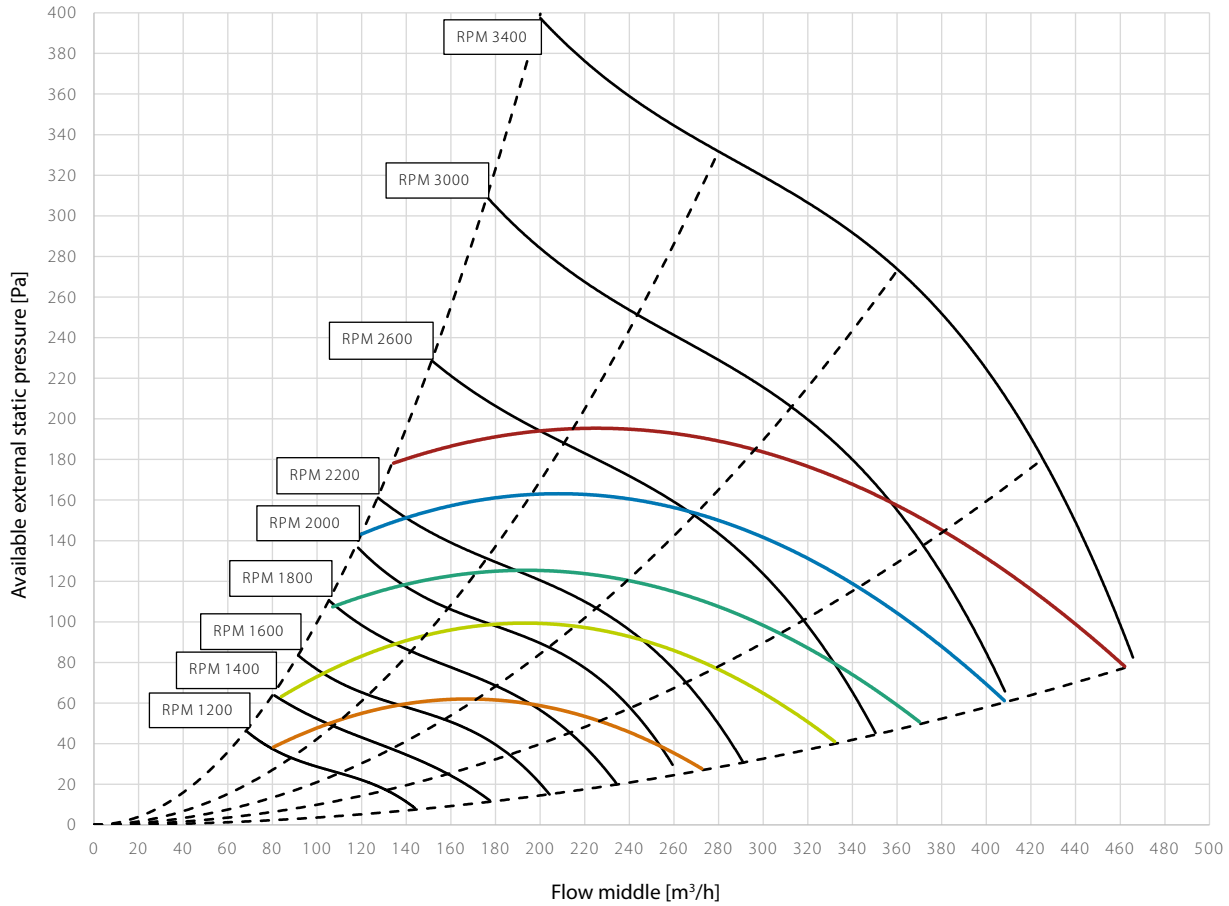

	—	—	—	—	—
SFP/SPI/SEL*	0,5 W/m³/h 1620 J/m³ 1.62 W/l/s	0.39 W/m³/h 1400 J/m³ 1.40 W/l/s	0.33 W/m³/h 1200 J/m³ 1.20 W/l/s	0.28 W/m³/h 1000 J/m³ 1.0 W/l/s	0.22 W/m³/h 800 J/m³ 0.80 W/l/s

* SFP/SPI/SEL includes power consumption of both fans and the control.

Thermal efficiency curves

Legend

- Thermal efficiency according to EN 13141-7 (dry)
Operational conditions: outdoor air: 7°C, 85% RH; extract air: 20°C, 37% RH
- Thermal efficiency according to EN 13141-7 (with condensation)
Operational conditions: outdoor air: 2°C, 85% RH; extract air: 20°C, 60% RH
- Thermal efficiency acc. PassivHaus Institut
Operational conditions: outdoor air: 4°C, 94% RH; extract air: 21°C, 30% RH

All values at balanced flow

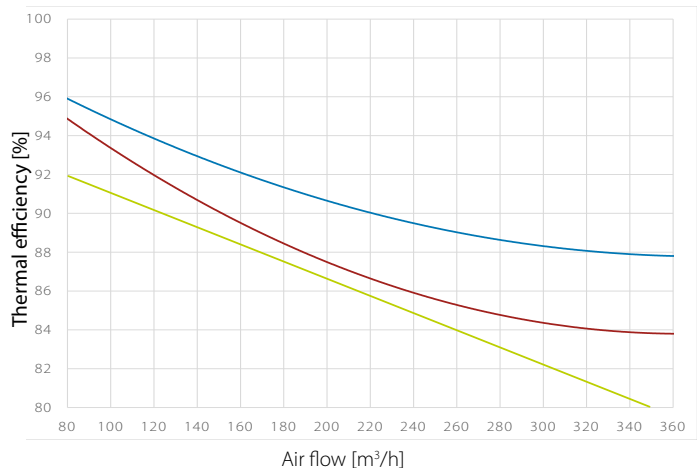

Sound power level (Lw) – ducts

RPM	Duct	[dB(A)]								
		63Hz	125Hz	250Hz	500Hz	1kHz	2kHz	4kHz	8kHz	Total
1200	supply/exhaust	26.9	29.6	30.6	30.6	25.8	23.0	11.7	16.4	36
	extract/outdoor	28.0	38.1	38.1	37.5	30.6	29.4	15.5	13.7	43
1300	supply/exhaust	28.8	30.1	32.5	32.4	27.5	24.6	14.5	17.9	37
	extract/outdoor	29.4	39.7	39.8	39.5	32.3	31.7	19.0	16.4	45
1400	supply/exhaust	29.7	30.5	34.4	34.5	29.4	27.1	16.6	19.6	39
	extract/outdoor	30.6	39.3	41.2	41.2	33.7	33.5	20.2	17.7	46
1500	supply/exhaust	31.1	31.3	37.0	36.5	31.3	29.3	18.2	21.0	41
	extract/outdoor	31.8	39.0	43.5	43.1	35.4	35.3	22.3	18.8	48
1600	supply/exhaust	31.9	32.0	38.6	38.0	32.8	31.1	20.3	21.6	43
	extract/outdoor	33.3	38.7	46.1	44.8	37.0	37.2	25.1	19.6	49
1700	supply/exhaust	32.5	32.5	41.6	39.7	34.2	32.6	20.9	22.1	45
	extract/outdoor	34.0	39.2	48.8	46.1	38.3	38.7	26.6	20.4	51
1800	supply/exhaust	32.0	31.1	42.4	41.4	35.9	34.5	22.7	22.6	46
	extract/outdoor	35.2	39.7	52.0	47.2	39.8	40.1	28.7	21.0	54
1900	supply/exhaust	33.1	32.3	43.7	42.8	37.3	36.1	24.6	23.0	47
	extract/outdoor	35.9	40.1	52.4	47.9	40.7	41.2	30.1	21.7	54
2000	supply/exhaust	34.0	33.1	45.3	43.5	38.5	37.2	25.4	23.4	49
	extract/outdoor	37.2	40.8	55.2	48.3	42.1	42.6	31.7	22.6	57
2100	supply/exhaust	34.9	33.6	46.6	44.4	39.8	38.4	26.7	23.8	50
	extract/outdoor	38.1	41.6	56.0	49.2	43.3	43.7	33.2	24.6	57
2200	supply/exhaust	36.7	35.4	48.3	45.4	41.3	39.8	28.6	24.1	51
	extract/outdoor	38.5	42.7	58.5	50.3	44.6	44.9	34.7	27.0	59
2300	supply/exhaust	37.2	36.2	50.9	46.7	42.6	41.0	30.2	24.5	53
	extract/outdoor	39.4	43.3	60.8	51.4	45.4	45.7	35.7	27.8	62
2400	supply/exhaust	38.2	37.0	51.1	47.9	43.6	42.1	31.6	24.7	54
	extract/outdoor	40.4	44.1	60.0	52.7	46.6	46.8	37.0	29.5	61
2500	supply/exhaust	39.3	37.7	51.7	48.9	44.6	43.0	32.7	25.6	55
	extract/outdoor	41.1	45.0	59.3	54.4	47.5	47.7	38.2	30.8	61
2600	supply/exhaust	40.8	38.6	52.3	50.3	45.7	44.0	33.9	27.3	55
	extract/outdoor	42.3	45.5	60.5	56.3	48.6	48.7	39.2	32.2	62
2700	supply/exhaust	40.8	39.3	53.0	51.9	46.6	44.8	34.9	27.6	56
	extract/outdoor	42.4	46.3	62.3	58.3	49.6	49.4	40.1	33.1	64
3000	supply/exhaust	44.3	41.5	52.0	57.2	49.6	47.5	37.9	30.8	59
	extract/outdoor	45.6	48.4	60.7	64.8	52.9	52.2	43.0	36.4	67
3400	supply/exhaust	48.6	44.0	51.2	62.2	52.4	50.3	41.0	33.9	63
	extract/outdoor	47.4	50.8	58.5	71.7	55.6	55.1	46.1	39.5	72

Sound pressure level (Lp) – cabinet**1m distance**

	[dB(A)]								
RPM	63Hz	125Hz	250Hz	500Hz	1kHz	2kHz	4kHz	8kHz	Total
1200	-	-	12.9	19.5	21.5	21.9	18.0	10.3	27
1400	-	5.7	18.5	23.8	23.5	23.5	18.5	10.6	29
1600	-	6.0	22.1	26.9	26.3	27.6	18.8	11.0	32
1800	-	6.9	25.3	29.4	28.2	28.3	20.6	12.0	34
2000	-	7.6	27.8	31.2	30.7	30.5	22.6	14.3	36
2200	-	8.0	31.3	33.3	32.6	32.8	24.8	17.4	39
2600	-	10.5	31.3	38.2	37.0	36.9	29.7	22.8	43
3000	-	13.1	31.4	43.1	40.2	40.0	33.0	26.1	47
3400	-	16.7	33.8	49.7	44.5	43.3	36.5	29.8	52

2m distance

	[dB(A)]								
RPM	63Hz	125Hz	250Hz	500Hz	1kHz	2kHz	4kHz	8kHz	Total
1200	-	-	8.7	18.6	21.5	21.9	18.0	10.3	27
1400	-	-	12.7	22.1	22.8	22.8	18.5	10.6	28
1600	-	-	16.9	25.3	25.5	24.9	18.8	11.0	31
1800	-	2.1	20.0	28.6	27.2	26.4	20.6	12.0	33
2000	-	3.5	22.9	30.9	29.4	28.5	21.7	13.6	35
2200	-	5.0	26.4	32.6	31.4	30.1	23.2	15.3	37
2600	-	8.1	27.3	37.2	36.3	33.8	27.1	19.9	41
3000	-	11.0	30.0	43.1	39.1	37.2	30.7	23.6	46
3400	-	14.0	30.9	49.7	42.7	41.6	34.1	27.1	51

Dimensions

On the HCV 460 it is possible to connect the supply duct to the bottom if the ducts are to run beneath the floor.

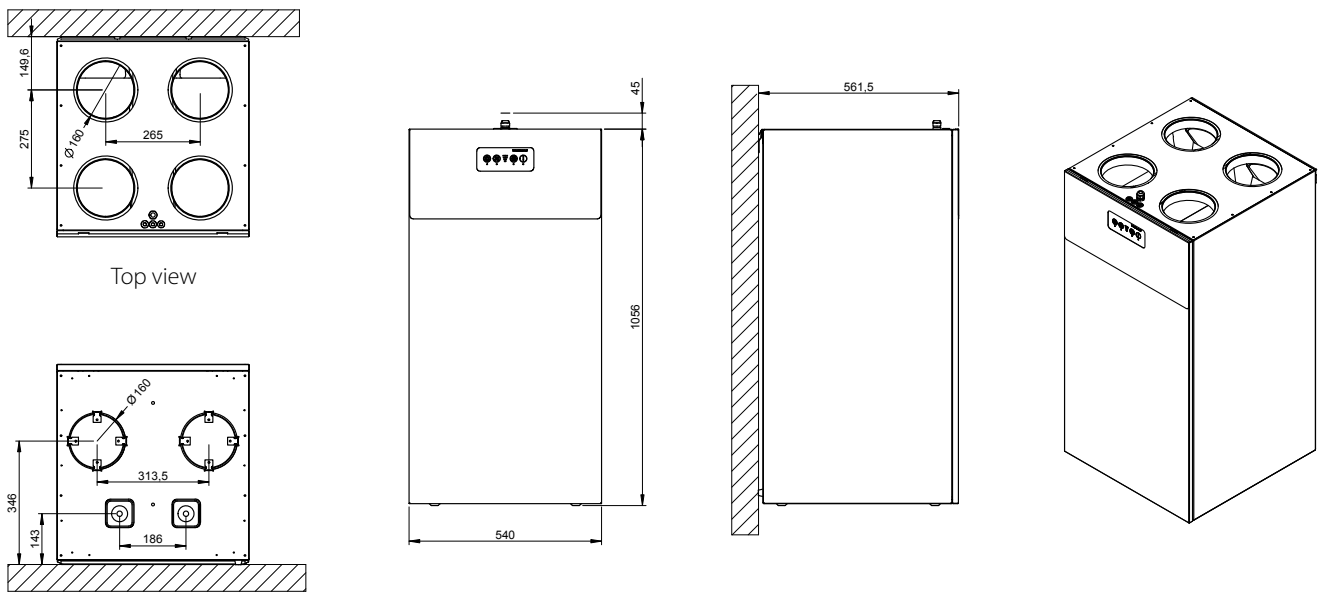

Top view

Bottom view



Revit files are available for free on request. Contact your local supplier or Dantherm for access.

Duct connections

2 set-up in 1 unit, easy change on site



HCV 460_{E1}



HCV 460_{E1}

The HCV 460_{E1} is a highly efficient residential ventilation unit for houses, villas, and apartments. It comes supplied as a packaged basic ventilation unit complete with built-in control panel, and is delivered with all parts necessary for wall installation. All HCV 460 units also fit perfectly in a 60 x 60cm cupboard.

The HCV 460_{E1} comes in galvanised metal surface. The units will be delivered on pallets of four to reduce packaging and shipping costs. This makes it ideal for large-scale projects.



- Demand-controlled ventilation with integrated humidity sensor, reducing power consumption at times with low ventilation demands
- Summer mode in which supply fan is stopped and any open window will supply cooler outside air, lowering the room temperature
- Automatic free-cooling features via inbuilt 100% by-pass, including the possibility of increasing the air flow automatically, lets in cool night air following hot days to help maintain a comfortable temperature throughout the day
- Fireplace mode, creating a temporary inside overpressure to enhance chimney functionality
- High-efficiency heat recovery
- EC fan motors with extremely low energy consumption (low SPI)
- Easy-to-install and commission solution with built-in air pressure spigots for easy calibration
- Highly customisable units with the option to add a high variety of internal as well as external accessories
- The HCV 460 takes up only as little space as a 60 x 60cm cupboard

Third party testing and certifications

Code	Description
EiP	Compliant with EU regulations for Eco-design
Nordic Swan Ecolabel	Listed in the Nordic Swan database for products suitable for Ecolabelled buildings
EPD	Environmental product declaration for declared product variant is available in the epddanmark.dk database

Specifications	Units		HCV 460 _{E1}
Maximum achievable flow at 100Pa	V100Pa	m ³ /h	460
Maximum declared flow at 100Pa	V _{max.rated}	m ³ /h	360
EN 13141-7 reference flow at 50Pa	V _{ref}	m ³ /h	252
Performance			
Thermal efficiency in accordance with EN13141-7	η_{SUP}	%	77
Leakage (external and internal) in accordance with EN13141-7		%	<2% (Class A1)
Filters in accordance with ISO16890	-	-	ISO Coarse 75% (optional on supply: ePM1>50%)
Filters in accordance with EN779			G4 (optional on supply: F7)
Installation surrounding temperature	t _{SURR}	°C	+12 to +50
Outdoor temperature without preheater installed	t _{ODA}	°C	-12 to +50
Outdoor temperature with preheater installed	t _{ODA}	°C	-20 to +50
Maximum absolute humidity in extract air	x	g/kg	10
Cabinet			
Exterior dimensions without wall brackets	w x h x d	mm	540 x 549 x 1050
Spigots/duct connections	Ø	mm	160 – female
Weight		kg	40
Heat conductivity – polystyrene insulation	λ	W/mK	0.031
Heat transfer coefficient of the polystyrene insulation	U	W/m ² K	U<1
Fire classification of the polystyrene insulation	class		"DIN 4102-1 class B2 EN 13501 class E"
Drainage hose (included)	Ø/length	"/m	¾/1
Cabinet colour		-	galvanised metal grey
Electrical			
Voltage	U	V	230
Maximum power consumption without/with preheater	P	W	230/2,080
Frequency	f	Hz	50
Protection class	-	-	IP21

* The use of preheating coil is recommended at outdoor temperature -3°C to ensure balanced operation.

** +20mm fitting.

Capacity and SPI curves with G4/G4 filters

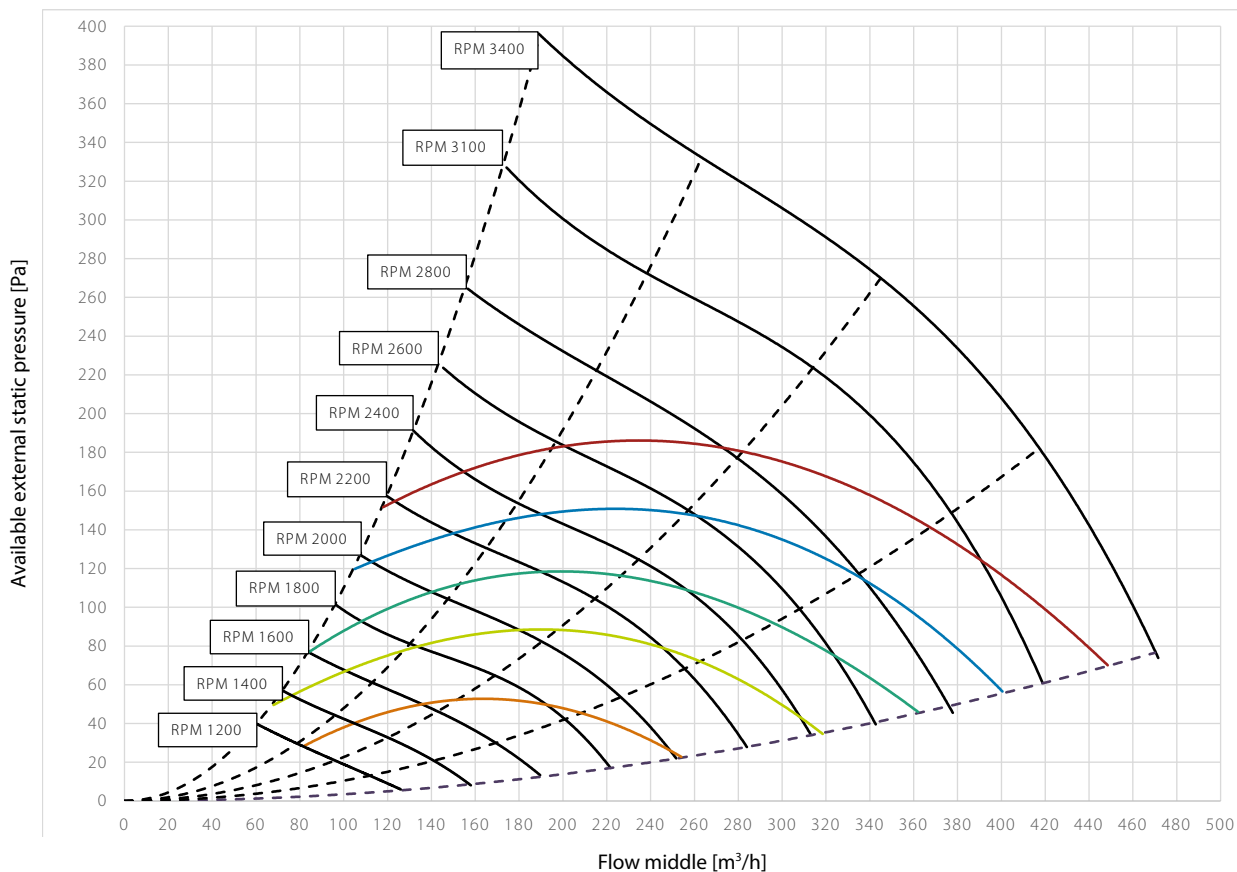

SFP/SPI/SEL*	0.45 W/m ³ /h	0.39 W/m ³ /h	0.33 W/m ³ /h	0.28 W/m ³ /h	0.22 W/m ³ /h
	1620 J/m ³	1400 J/m ³	1200 J/m ³	1000 J/m ³	800 J/m ³
	1.62 W/l/s	1.40 W/l/s	1.20 W/l/s	1.0 W/l/s	0.80 W/l/s

* SFP/SPI/SEL includes power consumption of both fans and the control.

Thermal efficiency curves

Legend

- Thermal efficiency according to EN 13141-7 (dry)
Operational conditions: outdoor air: 7°C, 85% RH; extract air: 20°C, 38% RH
- Humidity efficiency according to EN 13141-7 (with condensation)
Operational conditions: outdoor air: 2°C, 88% RH; extract air: 20°C, 60% RH

All values at balanced flow

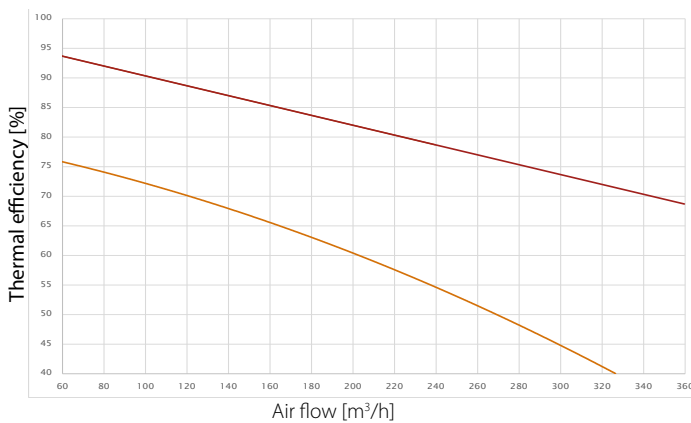

Sound power level (Lw) – ducts

RPM	Duct	[dB(A)]								
		63Hz	125Hz	250Hz	500Hz	1kHz	2kHz	4kHz	8kHz	Total
1200	supply/exhaust	28.6	31.3	32.3	32.3	26.8	23.0	11.7	14.5	37
	extract/outdoor	28.0	38.1	38.1	37.5	30.6	29.4	15.5	16.4	43
1300	supply/exhaust	30.5	31.8	34.2	34.1	28.5	24.6	14.5	17.9	39
	extract/outdoor	29.4	39.7	39.8	39.5	32.3	31.7	19.0	19.0	45
1400	supply/exhaust	31.4	32.2	36.1	36.2	30.4	27.1	16.6	18.3	41
	extract/outdoor	30.6	39.3	41.2	41.2	33.7	33.5	20.2	20.4	46
1500	supply/exhaust	32.8	33.0	38.7	38.2	32.3	29.3	18.2	19.6	43
	extract/outdoor	31.8	39.0	43.5	43.1	35.4	35.3	22.3	21.6	48
1600	supply/exhaust	33.6	33.7	40.3	39.7	33.8	31.1	20.3	20.4	44
	extract/outdoor	33.3	38.7	46.1	44.8	37.0	37.2	25.1	22.1	49
1700	supply/exhaust	34.2	34.2	43.3	41.4	35.2	32.6	20.9	21.0	46
	extract/outdoor	34.0	39.2	48.8	46.1	38.3	38.7	26.6	22.6	51
1800	supply/exhaust	33.7	32.8	44.1	43.1	36.9	34.5	22.7	21.6	47
	extract/outdoor	35.2	39.7	52.0	47.2	39.8	40.1	28.7	23.0	54
1900	supply/exhaust	34.8	34.0	45.4	44.5	38.3	36.1	24.6	22.1	49
	extract/outdoor	35.9	40.1	52.4	47.9	40.7	41.2	30.1	23.4	54
2000	supply/exhaust	35.7	34.8	47.0	45.2	39.5	37.2	25.4	23.0	50
	extract/outdoor	37.2	40.8	55.2	48.3	42.1	42.6	31.7	23.8	57
2100	supply/exhaust	36.6	35.3	48.3	46.1	40.8	38.4	26.7	23.8	51
	extract/outdoor	38.1	41.6	56.0	49.2	43.3	43.7	33.2	24.6	57
2200	supply/exhaust	38.4	37.1	50.0	47.1	42.3	39.8	28.6	24.1	53
	extract/outdoor	38.5	42.7	58.5	50.3	44.6	44.9	34.7	27.0	59
2300	supply/exhaust	38.9	37.9	52.6	48.4	43.6	41.0	30.2	24.5	55
	extract/outdoor	39.4	43.3	60.8	51.4	45.4	45.7	35.7	27.8	62
2400	supply/exhaust	39.9	38.7	52.8	49.6	44.6	42.1	31.6	24.7	55
	extract/outdoor	40.4	44.1	60.0	52.7	46.6	46.8	37.0	29.5	61
2500	supply/exhaust	41.0	39.4	53.4	50.6	45.6	43.0	32.7	25.6	56
	extract/outdoor	41.1	45.0	59.3	54.4	47.5	47.7	38.2	30.8	61
2600	supply/exhaust	42.5	40.3	54.0	52.0	46.7	44.0	33.9	27.3	57
	extract/outdoor	42.3	45.5	60.5	56.3	48.6	48.7	39.2	32.2	62
2700	supply/exhaust	42.5	41.0	54.7	53.6	47.6	44.8	34.9	27.6	58
	extract/outdoor	42.4	46.3	62.3	58.3	49.6	49.4	40.1	33.1	64

Sound pressure level (Lp) – cabinet**1m distance**

RPM	[dB(A)]								
	63Hz	125Hz	250Hz	500Hz	1kHz	2kHz	4kHz	8kHz	Total
1200	-	-	12.9	19.5	21.5	21.9	18.0	10.3	27
1400	-	5.7	18.5	23.8	23.5	23.5	18.5	10.6	29
1600	-	6.0	22.1	26.9	26.3	27.6	18.8	11.0	32
1800	-	6.9	25.3	29.4	28.2	28.3	20.6	12.0	34
2000	-	7.6	27.8	31.2	30.7	30.5	22.6	14.3	36
2200	-	8.0	31.3	33.3	32.6	32.8	24.8	17.4	39
2600	-	10.5	31.3	38.2	37.0	36.9	29.7	22.8	43
3000	-	13.1	31.4	43.1	40.2	40.0	33.0	26.1	47
3400	-	16.7	33.8	49.7	44.5	43.3	36.5	29.8	52

2m distance

RPM	[dB(A)]								
	63Hz	125Hz	250Hz	500Hz	1kHz	2kHz	4kHz	8kHz	Total
1200	-	-	8.7	18.6	21.5	21.9	18.0	10.3	27
1400	-	-	12.7	22.1	22.8	22.8	18.5	10.6	28
1600	-	-	16.9	25.3	25.5	24.9	18.8	11.0	31
1800	-	2.1	20.0	28.6	27.2	26.4	20.6	12.0	33
2000	-	3.5	22.9	30.9	29.4	28.5	21.7	13.6	35
2200	-	5.0	26.4	32.6	31.4	30.1	23.2	15.3	37
2600	-	8.1	27.3	37.2	36.3	33.8	27.1	19.9	41
3000	-	11.0	30.0	43.1	39.1	37.2	30.7	23.6	46
3400	-	14.0	30.9	49.7	42.7	41.6	34.1	27.1	51

Dimensions

On the HCV 460 it is possible to connect the supply duct to the bottom if the ducts are to run beneath the floor.

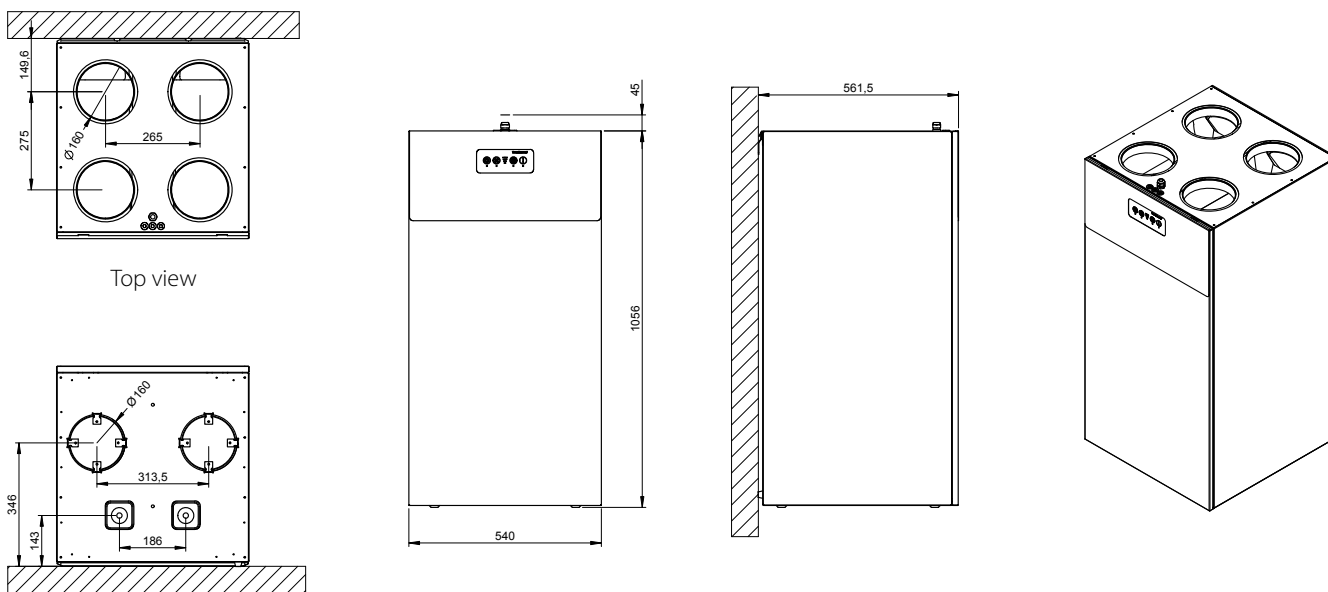

Top view

Bottom view



Revit files are available for free on request. Contact your local supplier or Dantherm for access.

Duct connections

2 set-up in 1 unit, easy change on site

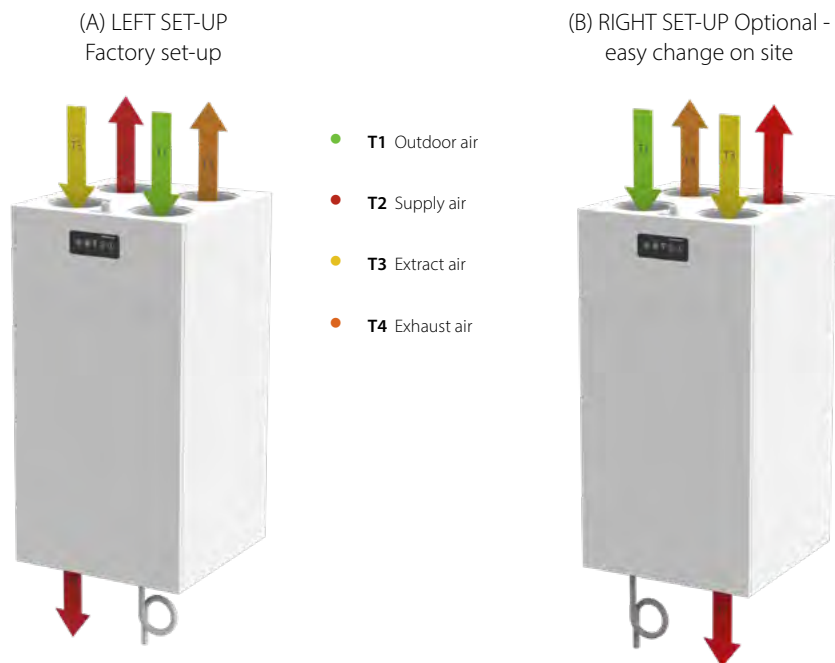

HCV 700



HCV 700

The HCV 700 is a highly efficient residential ventilation unit for houses, villas, and apartments of up to 450m² or more. It comes supplied as a packaged basic ventilation unit complete with built-in control panel, and are delivered with all parts necessary for wall installation. The HCV 700 is ideal for free wall installation with minimum 700mm space. A standard wall rail is supplied with all units.



- Demand-controlled ventilation with integrated humidity sensor, reducing power consumption at times with low ventilation demands
- Summer mode, in which supply fan is stopped and any open window will supply cooler outside air, lowering the room temperature
- Automatic free-cooling features via inbuilt 100% by-pass, including the possibility of increasing the air flow automatically, lets in cool night air following hot days to help maintain a comfortable temperature throughout the day
- Fireplace mode, creating a temporary inside overpressure, to enhance chimney functionality
- High-efficiency heat recovery
- EC fan motors with extremely low energy consumption (low SPI)
- Easy-to-install and commission solution with built-in air pressure spigots for easy calibration
- Highly customisable units, with the option to add a high variety of internal as well as external accessories
- A standard wall rail is supplied with the unit

Third party testing and certifications

Code	Description
PHI Pending	Passivhaus certified
DIBt Pending	Certified by the German Institute of Construction Technology
EPB	Listed in the database for Energy Performance of Buildings in Belgium
ErP	Compliant with EU regulations for Eco-design
Nordic Swan Ecolabel	Listed in the Nordic Swan database for products suitable for Ecolabelled buildings

Specifications	Units		HCV 700
Maximum achievable flow at 100Pa	V _{100Pa}	m ³ /h	550
Maximum declared flow at 100Pa	V _{max, rated}	m ³ /h	450
Recommended operating range	V	m ³ /h	80-450
EN 13141-7 reference flow at 50Pa	V _{ref}	m ³ /h	315
Performance			
Thermal efficiency in accordance with EN13141-7	η_{SUP}	%	85
Specific power consumption in accordance with EN13141-7	SFP	W/m ³ /h	0.22
Leakage (external and internal) in accordance with EN13141-7	-	%	<2% (Class A1)
Filters in accordance with ISO16890	-	-	ISO Coarse 75% (optional on supply: ePM1>50%)
Filters in accordance with EN779	-	-	G4 (optional on supply: F7)
Installation ambient temperature	t _{surp}	°C	+12 to +50
Outdoor temperature range without preheater installed	t _{ODA}	°C	-12* to +50
Outdoor temperature range with preheater installed	t _{ODA}	°C	-20 to +50
Maximum absolute humidity in extract air	x	g/kg	10
Cabinet			
Dimensions (without wall bracket)	w x d x h	mm	700 x 750 x 1050
Spigots/duct connections	Ø	mm	200 – female
Weight		kg	70
Thermal conductivity – polystyrene insulation	λ	W/mK	0.031
Heat transition figures – polystyrene insulation	U	W/m ² K	<1
Fire classification of the polystyrene insulation	-	-	DIN 4102-1 class B2 EN 13501 class E
Drainage hose	Ø/length	"/m	¾/1
Cabinet colour	RAL	-	9016
Electrical			
Voltage	U	V	230
Maximum power consumption (without/with preheater)	P	W	234/1,834
Frequency	f	Hz	50
Protection class	-	-	IP21

* The use of the preheating coil is recommended at outdoor temperature below -3°C to ensure balanced operation.

Capacity and SPI curves with G4/G4 filters

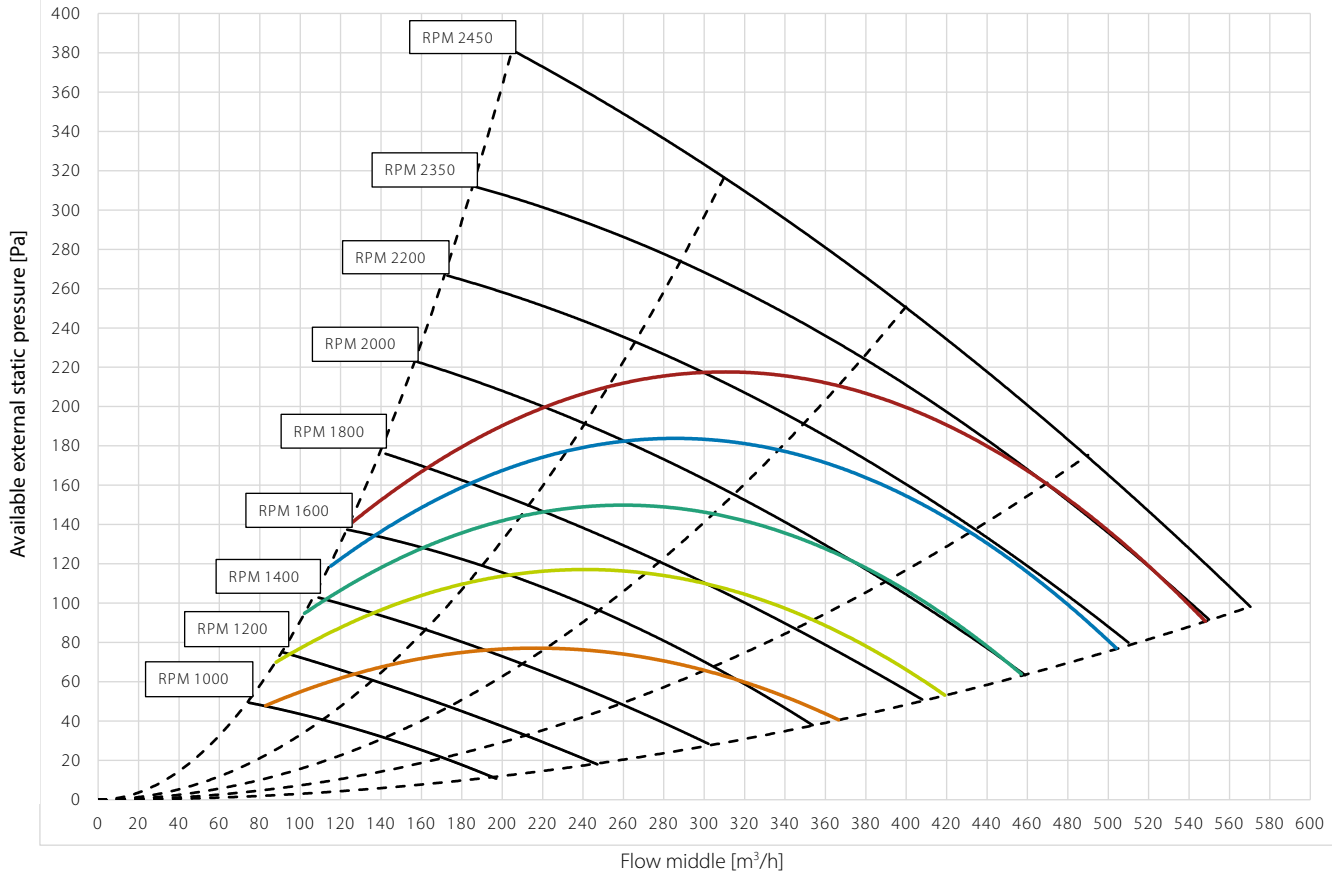

	—	—	—	—	—
SFP/SPI/SEL*	0.45 W/m ³ /h	0.39 W/m ³ /h	0.33 W/m ³ /h	0.28 W/m ³ /h	0.22 W/m ³ /h
	1620 J/m ³	1400 J/m ³	1200 J/m ³	1000 J/m ³	800 J/m ³
	1.62 W/l/s	1.40 W/l/s	1.20 W/l/s	1.0 W/l/s	0.80 W/l/s

* SFP/SPI/SEL includes power consumption of both fans and the control.

Thermal efficiency curves

Legend

- Thermal efficiency according to EN 13141-7 (dry)
Operational conditions: outdoor air: 7°C, 85% RH; extract air: 20°C, 37% RH
- Thermal efficiency according to EN 13141-7 (with condensation)
Operational conditions: outdoor air: 2°C, 87% RH; extract air: 20°C, 60% RH

All values at balanced flow

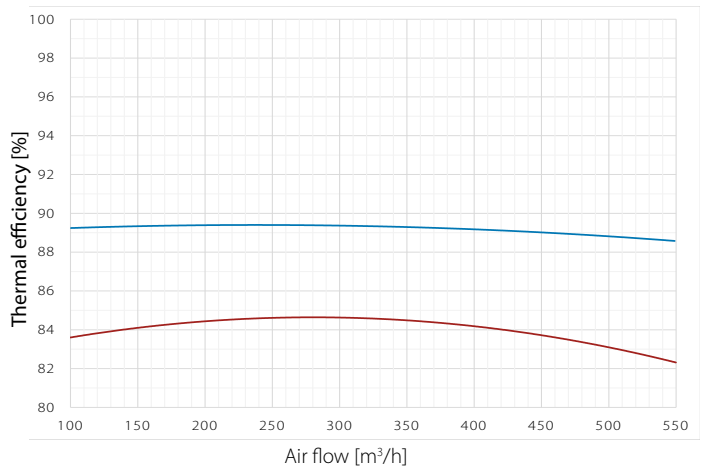

Sound data with G4/G4 filters

Air volume m ³ /h	Pres- sure Pa	Operatio- nal point	Frequency band sound power Lw(A) dB(A)								Total sound power Lw(A) dB(A)	Sound pres- sure standard room* Lp(A) dB(A)
			63Hz	125Hz	250Hz	500Hz	1000Hz	2000Hz	4000Hz	8000Hz		
350	100	Supply air	54	55	64	57	53	45	35	27	65.5	
		Extract air	63	62	68	63	56	52	44	34	71.1	
		Cabinet	36	45	55	52	50	43	28	20	57.8	53

Dimensions

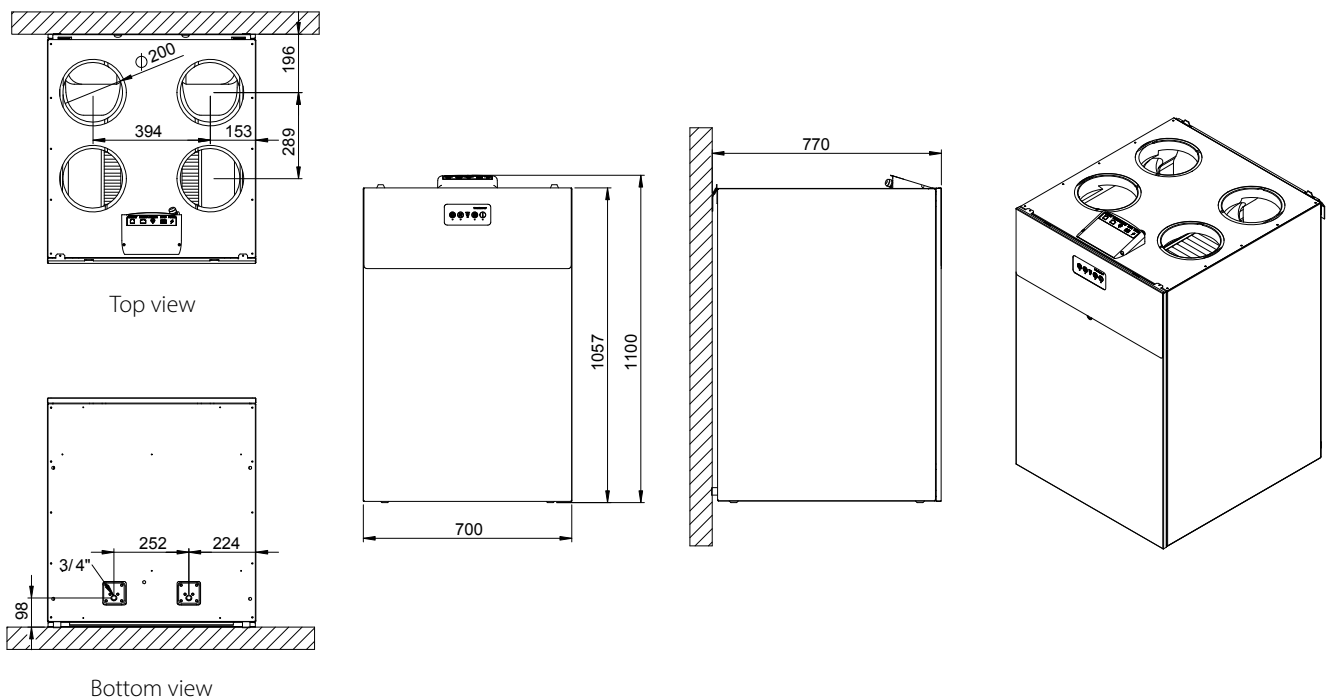

Revit files are available for free on request. Contact your local supplier or Dantherm for access.

RCC RANGE



Ideal for small residential areas

The RCC range has been designed to cover ventilation needs in apartments and other residential areas of up to 80m² with a particular focus on installation flexibility, safety and ease of maintenance.

One unit fits all installation scenarios

Unique to the residential ventilation market, the RCC offers a stunning 96 different ways of connecting ducts to the unit. 6 different mounting options each offering 16 duct connection combinations. (A) setups are the standard configuration, (B) can be configured on site.

The air flow direction can be electronically swapped, thereby making it possible to route the connected ducts either to the right or to the left. This means that the supply air duct connections can be placed either on the right or to the left hand side of the unit.

Moreover, the factory-mounted duct seals on the side of the unit can easily be removed using a side cutter and then used to seal off other ducts not to be used.

This means that you can use the same unit for all installation scenarios. There is no risk of ordering units that have been preconfigured incorrectly for your needs.



DUCT SEALS CAN BE MOVED TO FIT YOUR SETUP

RCC RANGE



(A) LEFT SET-UPS
Standard configuration

(B) RIGHT SET-UPS
Can be configured on site

(A) UNDER CEILING

(B) UNDER CEILING



(A) WALL, VERTICAL

(B) WALL, VERTICAL

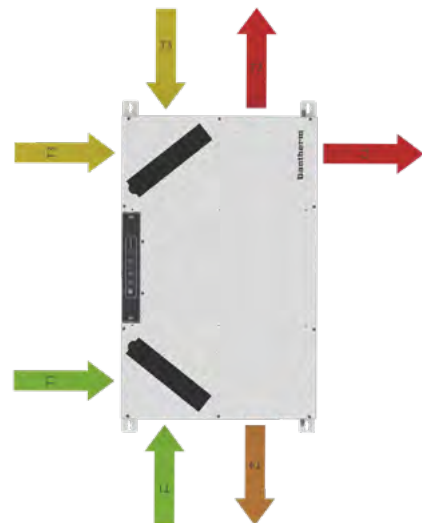
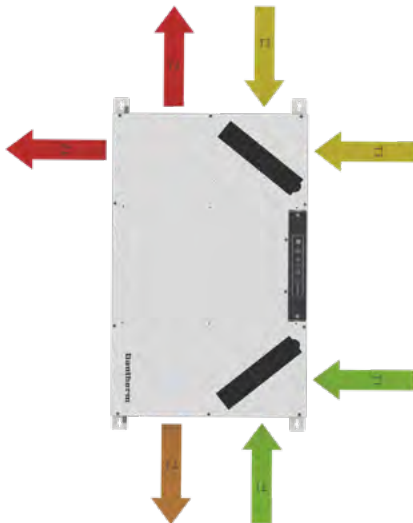

(A) WALL, HORIZONTAL

(B) WALL, HORIZONTAL

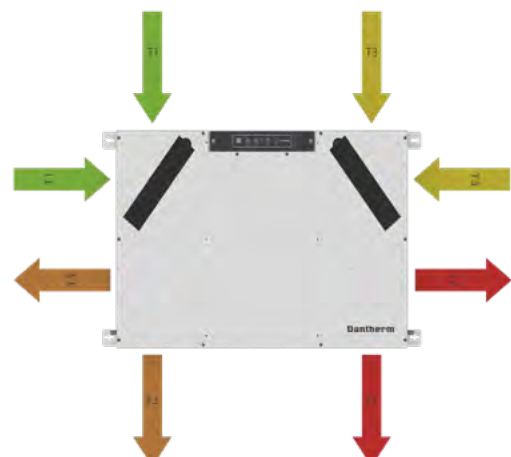
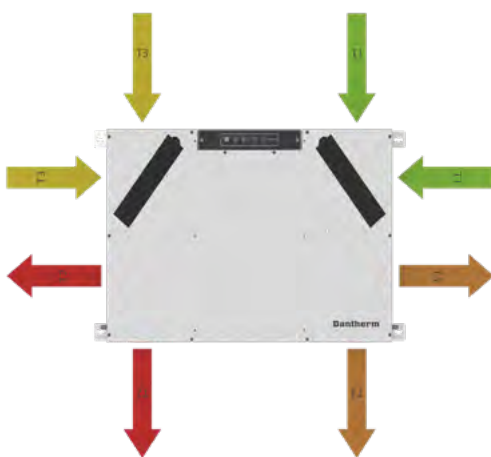

- T1 Outdoor air
- T2 Supply air
- T3 Extract air
- T4 Exhaust air

RCC 220P2



RCC 220P2

The RCC 220P2 is a uniquely flexible and compact residential ventilation unit for small houses and apartments. Based on an ingenious design, it is delivered as a true plug and play solution with a built-in control panel and all necessary parts for on-site installation.

Requiring just 200mm installation headroom, it is perfect for installation in suspended ceilings, on (or inside!) walls or closets. The air flows can be electronically swapped, so the same unit can be mounted with inside/outside ducts connected to either the right or left hand side as needed.

The RCC units come with a galvanised metal surface and are either delivered packaged individually one unit on a pallet in a cardboard box or in a variant packaged four units on a pallet to minimise use of packaging in consideration of the environment and to ease handling at building sites.



- Demand-controlled ventilation with integrated humidity sensor, reducing power consumption at times with low ventilation demands
- Summer mode in which the supply fan is stopped to reduce power consumption. Open windows will supply cooler outside air
- Automatic free-cooling via the integrated bypass function that lets in cool night air on hot days to help maintain comfortable temperatures through the day
- Fireplace mode, creating a temporary inside overpressure to enhance chimney functionality
- High-efficiency heat recovery
- EC fan motors with extremely low energy consumption (low SPI)
- Requires no more than 200mm installation headroom
- Highly customisable units with the option to add a high variety of internal as well as external accessories
- Two humidity sensors to ease switching from left/right setup
- Prepared for easy mounting of condensate pump

Third party testing and certifications

Code	Description
PHI	Pending Passivhaus
DIBt	Pending the German Institute of Construction Technology
PCDB listed SAP App. Q	Pending (listed in the UK database for balanced whole-house mechanical ventilation with heat recovery)
ErP	Compliant with EU regulations for Eco-design
Nordic Swan Ecolabel	Listed in the Nordic Swan database for products suitable for Ecolabelled buildings
EPD	Environmental product declaration for declared product variant is available in the epddanmark.dk database

Specifications	Units		RCC 220P2
Maximum achievable flow at 100Pa	V100Pa	m ³ /h	220
Maximum declared flow at 100Pa	V _{max.rated}	m ³ /h	120
Recommended operating range	V	m ³ /h	45-130
Operating range DIBt	V _{DBIt}	m ³ /h	45-120
Operating range Passivhaus at 100Pa	V _{PHI}	m ³ /h	45-115
EN 13141-7 reference flow at 50Pa	V _{REF}	m ³ /h	84

Performance

Thermal efficiency in accordance PHI	η_{SUP}	%	84 (preliminary)
Thermal efficiency in accordance with EN13141-7	η_{SUP}	%	86
Leakage (external and internal) in accordance with EN 13141-7			<2% (Class A1)
Filters in accordance with ISO16890	-	-	ISO Coarse 75% (optional on supply: ePM1>50%)
Filters in accordance with EN779	-	-	G4 (optional on supply: F7)
Installation surrounding temperature	t _{SURR}	°C	+12 to +45
Outdoor temperature without preheater installed	t _{ODA}	°C	-12* to +45
Outdoor temperature with preheater installed	t _{ODA}	°C	-20 to +45
Maximum absolute humidity of extract air	x	g/kg	10

Cabinet

Dimensions (without wall bracket)	w x h x d	mm	580 x 200 x 900
Spigots/duct connections	Ø	mm	8 x Ø125 – female
Weight		kg	17
Heat conductivity – polystyrene insulation	λ	W/mK	0.031
Heat transfer coefficient – polystyrene insulation	U	W/m ² K	U<1
Fire classification of the polystyrene insulation	-		DIN 4102-1 class B2 EN 13501 class E
Drainage hose (accessory)	Ø	"	1/2
Cabinet colour	RAL	-	Galvanised metal grey

Electrical

Voltage	U	V	230
Maximum power consumption (without/with preheater)	P	W	173/1073
Frequency	f	Hz	50
Protection class	-	-	IP21

* The use of preheating coil is recommended at outdoor temperature -3°C to ensure balanced operation.

Capacity and SPI curves with G4/G4 filters

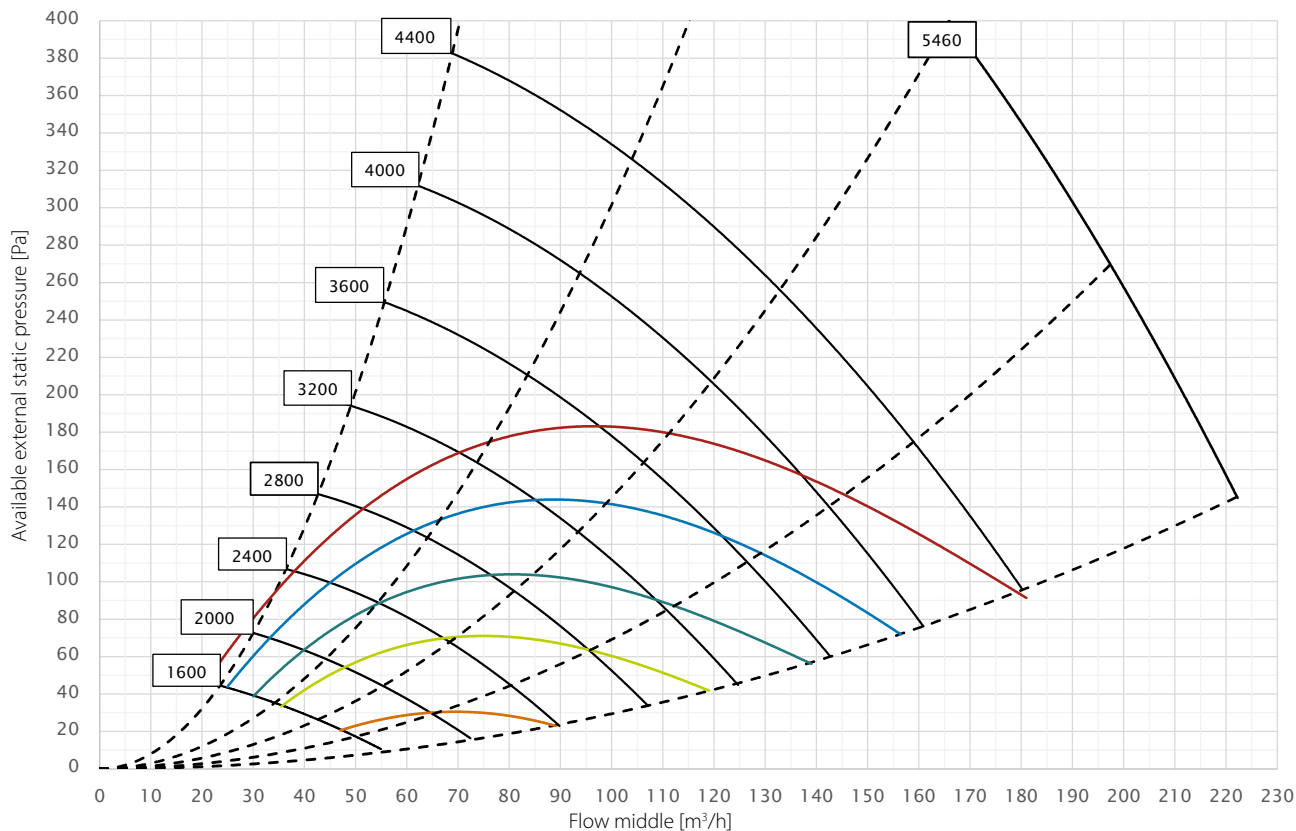

	—	—	—	—	—
SFP/SPI/SEL*	0.45 W/m ³ /h	0.39 W/m ³ /h	0.33 W/m ³ /h	0.28 W/m ³ /h	0.22 W/m ³ /h
	1620 J/m ³	1400 J/m ³	1200 J/m ³	1000 J/m ³	800 J/m ³
	1.62 W/l/s	1.40 W/l/s	1.20 W/l/s	1.0 W/l/s	0.80 W/l/s

* SFP/SPI/SEL includes power consumption of both fans.

Thermal efficiency curves

Legend

- Thermal efficiency according to EN 13141-7 (dry)
Operational conditions: outdoor air: 7°C, 85% RH; extract air: 20°C, 37% RH

All values at balanced flow

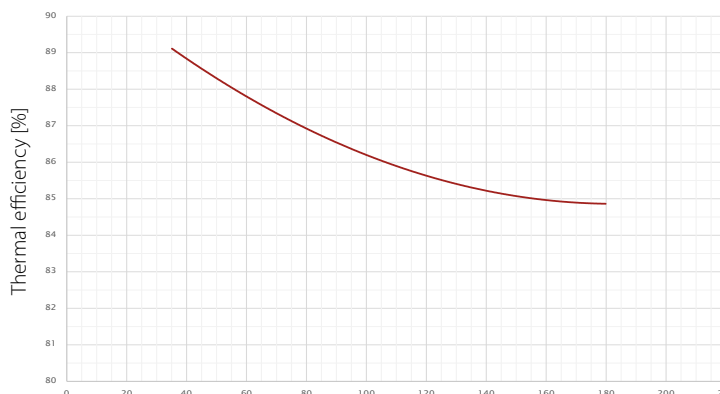

Sound power level (Lw) – ducts

RPM	Duct	[dB(A)]								
		63Hz	125Hz	250Hz	500Hz	1kHz	2kHz	4kHz	8kHz	Total
800	supply/exhaust	12.9	23.6	19.3	19.8	26.3	13.4	-	-	29.4
	extract/outdoor	-	15.3	12.6	-	14.8	10.8	-	-	19.7
1200	supply/exhaust	18.3	39.2	29.8	30.8	30.6	21.2	11.4	-	40.7
	extract/outdoor	10.0	33.1	19.7	19.0	16.8	11.2	-	-	33.6
1600	supply/exhaust	23.8	41.4	44.5	41.8	37.0	28.7	22.8	-	48.0
	extract/outdoor	18.3	33.5	33.6	29.4	20.6	12.5	12.7	-	37.9
2000	supply/exhaust	28.0	43.4	52.3	46.5	41.8	35.9	30.7	-	54.1
	extract/outdoor	22.6	34.5	38.8	33.4	24.6	15.0	14.6	-	41.4
2200	supply/exhaust	29.0	44.4	54.7	47.7	44.8	38.6	34.6	13.4	56.3
	extract/outdoor	24.4	34.9	41.4	34.9	26.3	17.0	15.4	-	43.2
2400	supply/exhaust	31.4	45.4	57.2	49.5	47.6	42.7	38.5	20.6	58.6
	extract/outdoor	26.2	35.4	44.8	37.0	27.8	20.2	16.0	-	46.0
2600	supply/exhaust	33.0	46.6	59.0	52.3	49.5	44.3	40.9	21.7	60.5
	extract/outdoor	28.5	37.3	45.1	38.1	28.9	21.8	16.0	-	46.6
2800	supply/exhaust	34.7	47.9	60.7	55.2	51.4	45.9	43.3	22.7	62.5
	extract/outdoor	29.7	38.7	50.8	43.6	31.7	25.4	16.5	-	51.9
3000	supply/exhaust	36.8	48.9	60.7	61.8	53.0	47.7	45.1	25.4	64.9
	extract/outdoor	32.5	40.4	50.9	49.5	34.5	26.4	18.8	-	53.6
3200	supply/exhaust	38.9	49.9	60.7	68.4	54.6	49.6	47.0	27.5	69.4
	extract/outdoor	32.8	41.9	50.9	56.4	39.8	29.2	20.7	-	57.7
3400	supply/exhaust	39.3	50.9	60.7	69.7	56.3	51.2	48.9	29.8	70.5
	extract/outdoor	37.4	43.4	50.9	57.5	40.5	30.5	23.2	-	58.6
3600	supply/exhaust	39.7	51.9	60.7	71.0	58.0	52.8	50.8	31.9	71.7
	extract/outdoor	37.4	43.5	51.0	58.5	41.2	32.6	24.9	-	59.4
4000	supply/exhaust	43.8	54.4	60.7	71.0	60.8	56.2	53.8	35.6	72.0
	extract/outdoor	37.8	43.6	51.1	60.6	41.3	35.8	28.2	-	61.2
4400	supply/exhaust	43.9	56.2	60.7	71.0	62.5	58.5	56.7	39.3	72.3
	extract/outdoor	38.1	51.0	51.2	60.6	41.8	38.7	31.0	-	61.6
5400	supply/exhaust	47.2	57.4	60.7	71.0	68.3	63.3	61.5	45.5	73.9
	extract/outdoor	39.6	51.0	51.3	60.6	49.2	44.5	37.1	19.8	61.9

Sound pressure level (Lp) – cabinet**1m distance**

RPM	Without background noise weighted [dB(A)]								
	63Hz	125Hz	250Hz	500Hz	1kHz	2kHz	4kHz	8kHz	Total
800	-	-	14.1	16.3	4.7	13.8	13.7	12.9	21.4
1200	-	10.6	16.0	22.1	22.1	18.9	13.7	13.8	27.0
1600	-	12.0	17.3	23.8	22.1	24.1	20.2	18.6	29.6
2000	-	15.1	22.4	30.0	25.5	25.6	21.2	18.9	33.3
2200	-	16.4	24.5	32.5	27.5	25.6	22.4	19.5	35.2
2400	10.9	18.7	26.9	34.7	29.4	26.7	23.5	20.1	37.2
2600	12.7	19.9	28.0	36.6	31.9	29.0	25.4	21.1	39.1
2800	13.9	21.4	30.1	38.5	33.2	29.0	25.5	21.3	40.6
3000	15.2	22.8	31.5	41.1	34.9	29.0	25.7	21.6	42.8
3200	16.7	23.4	31.5	41.8	36.2	29.1	27.4	22.0	43.5
3400	18.3	24.6	32.5	43.8	38.0	30.7	28.3	22.3	45.4
3600	19.9	26.0	33.8	45.5	39.9	32.9	29.5	22.6	47.1
4000	22.0	27.9	36.0	50.3	43.2	35.8	33.1	23.1	51.4
4400	25.3	29.5	38.0	52.5	46.1	37.9	35.0	23.5	53.7
5000	28.6	33.1	40.6	53.4	50.0	41.5	38.6	24.9	55.5

2m distance

RPM	Without background noise weighted [dB(A)]								
	63Hz	125Hz	250Hz	500Hz	1kHz	2kHz	4kHz	8kHz	Total
800	-	-	13.4	15.7	4.7	13.5	13.4	12.7	21.0
1200	-	-	15.6	21.2	21.9	18.9	13.7	13.7	26.5
1600	-	-	15.8	21.7	21.9	19.4	16.7	14.6	27.0
2000	-	11.7	20.7	25.4	26.3	19.9	18.6	15.4	30.5
2200	-	13.0	21.5	28.9	26.9	20.4	20.0	16.2	32.2
2400	-	16.3	24.6	30.8	30.2	20.6	21.2	16.9	34.6
2600	11.5	17.8	26.8	33.7	32.3	24.6	22.9	17.6	37.1
2800	12.4	18.4	27.9	35.6	34.2	24.7	24.0	18.2	38.8
3000	14.2	20.1	29.1	38.1	37.3	28.5	26.4	20.6	41.5
3200	15.2	20.8	29.1	39.8	38.3	28.9	26.8	21.3	42.7
3400	17.7	22.1	30.6	41.8	40.0	29.7	27.4	21.9	44.5
3600	18.7	23.2	31.5	43.4	41.8	31.5	29.3	22.4	46.1
4000	21.1	25.0	33.6	46.8	44.5	33.8	31.5	23.0	49.2
4400	23.4	26.9	35.3	50.1	47.4	36.1	34.2	23.5	52.3
5000	27.8	32.1	38.2	54.1	51.8	39.8	37.5	24.8	56.4

Dimensions

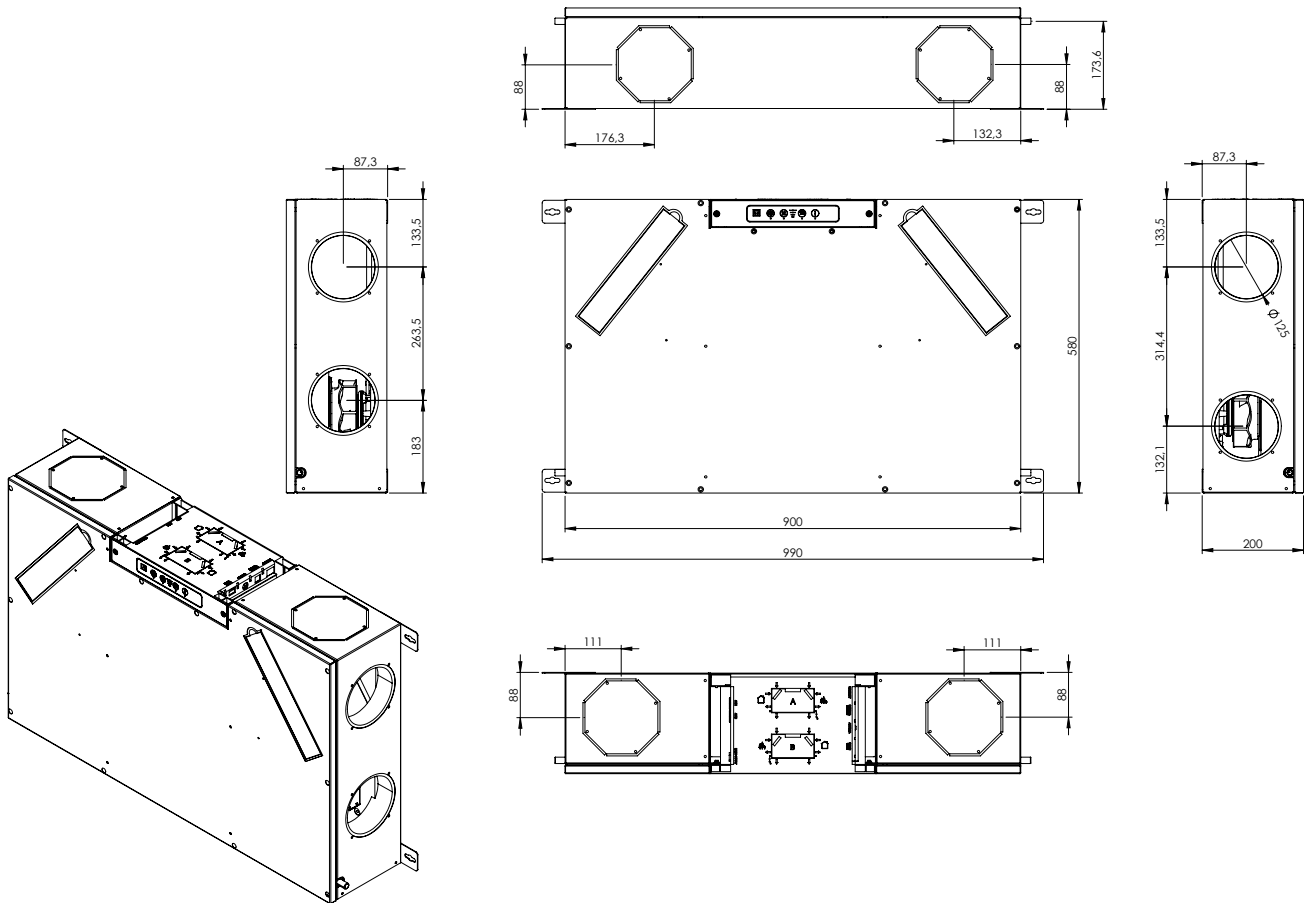

REVIT

Revit files are available for free on request.
Contact your local supplier or Dantherm for access.

HCC RANGE



PAINTED IN RAL 9016



SURFACE IN GALVANISED METAL

Model range

The HCC range is available in a variant with an galvanised metal surface, standard filter resetting capability as well as easy PCB access to connect accessories. Delivered four units on a pallet at a time, it also minimises the use of packaging in consideration of the environment.

Overview

The HCC residential ventilation unit is primarily designed for new constructions or retrofitting into multiple apartment buildings. The outer dimensions and design allow easy installation into a suspended ceiling or onto a wall, hidden inside a closet.

The unit is supplied as a basic unit, with the option of fitting a wide range of accessories into the unit, thus extending the comfort and reducing the energy consumption.

The residential ventilation unit is equipped with a highly efficient plastic counter-flow heat exchanger, which is optimised to a high efficiency level. This, combined with a low headroom, results in a very slim ventilation unit, easily hidden in a suspended ceiling, together with the duct system.

HCC enclosure

The unit enclosure is designed to fit low headroom suspended ceilings, and yet still with easy service access. The outer surface is 0.8mm galvanised metal powder coated sheet, which comes in options painted with white in RAL 9010 or not, with two external lids covering the two filter slots.

All inside air paths and insulation, is made of EPS (Polystyrene). This has a high insulation level, and good air tightness, which permits location of the units in spaces with temperatures down to +12°C .

Because of their ability to be either ceiling- or wall-mounted, the units will fit into almost any residential area without being visible.

Function

The unit ventilates residential homes by extracting the inside humid air, and replacing it with fresh outside air, which has been heated with the heat energy of the extracted air. This reduces energy consumption.



HCC RANGE



When very humid inside air is extracted, the humidity will condensate inside the heat exchanger, and be collected by the embedded drip tray. This water is drained from the unit through the enclosed hose and then disposed of in the nearest drainage.

Mirroring all duct connections

The air flow direction can be electronically swapped, providing ability to route the connected ducts, either to the right or to the left. This means that the supply air duct connections can be either to the right or to the left hand side of the unit. (Supply air and extract air duct connections always towards the inside of the house and outside air and exhaust air ducts always towards the outside of the house).

All electrical cables can be connected from either the left or the right hand side, regardless of fan direction.

Filters

Requiring no tools, users can change the filter on their own and then reset the filter timer using the standard filter resetting button (HCC 260 and HCC 360) or the optional HCP 11 wired control. If no controls are available, the filter is to be changed by an installer with the appropriate PC Tool on his laptop for resetting the filter timer.

Apart from changing the air filters and cleaning the outside of the unit, any other form of service will have to be carried out by qualified personnel. Local Dantherm technicians and Dantherm partners are always available to solve any problem with the unit that might arise.

Removing the front cover gives access to all types of service and repair.

Installation parts

The enclosed mounting bracket is designed to conduct a safe installation process, and is suitable for both wall and ceiling installation.

The mounting bracket will tilt the unit slightly towards the drainage spigot, ensuring correct drainage of any condensed water inside the unit when used for ceiling installation. It will also offer a easy wall installation process.

ILLUSTRATION OF DUCT CONNECTIONS IN FAN DIRECTION MODE A

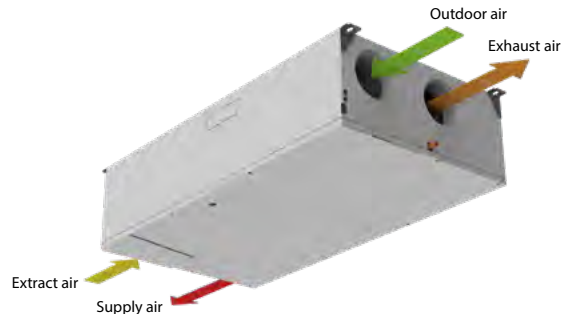
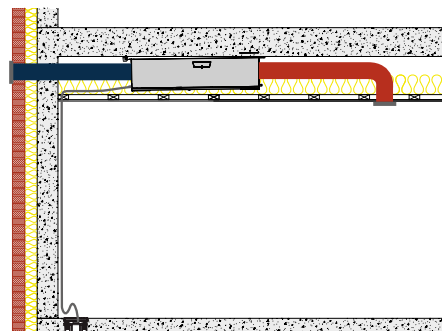
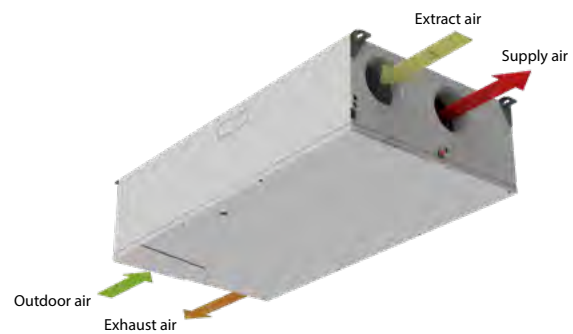
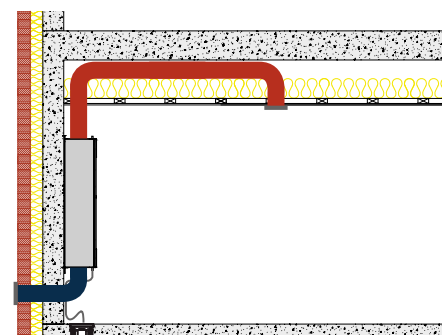

ILLUSTRATION OF DUCT CONNECTIONS IN FAN DIRECTION MODE B



HCC 2 IN SUSPENDED CEILING



HCC 2 ON WALL

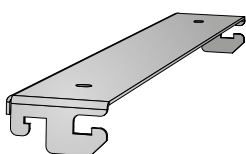

UNIVERSAL MOUNTING BRACKET



FILTER CHANGE

HCC 2PLA



HCC 2PLA

The HCC 2 is a unique and flexible residential ventilation solution. With only 30cm installation headroom it is ideal for installation in suspended ceilings or onto a wall, even hidden inside a closet. The unit can be electronically reversed, meaning that both air flows will be reversed. This allows the same unit type to be mounted with the inside/outside ducts connected to either the right or the left hand side of the unit. Electrical connections can be connected from either the left or the right.



- High efficiency heat recovery – up to 94%
- EC fan motors with low energy consumption (low SPI)
- Only 300mm installation headroom height is required
- Time controlled ventilation level, based on 11 different built-in pre-programmed week programs, reducing power consumption in periods with low ventilation demands
- Summer cooling mode
- Automatic free-cooling features via inbuilt 100% by-pass, including the possibility of increasing the air flow automatically, lets in cool night air following hot days to help maintain a comfortable temperature throughout the day
- Fireplace mode, creating a momentary inside overpressure, to enhance chimney functionality
- Easy-to-install and commissioning solution with built in air measure ports, for easy balancing with PC Tool
- Electronically left/right fan direction switching, allowing same unit type to adapt any physical installation requirements, regardless of ceiling and wall selection
- TCP/IP ModBus connection, for inter-operation with Building Management System
- Electrical connections can be connected from either the left or the right

Third party testing and certifications

Code	Description
PHI	Passivhaus certified
DIBt	Certified by the German Institute of Construction Technology
EPB	Listed in the database for Energy Performance of Buildings in Belgium
ErP	Compliant with EU regulations for Eco-design
Nordic Swan Ecolabel	Listed in the Nordic Swan database for products suitable for Ecolabelled buildings

Specifications	Units		HCC 2PLA
Maximum achievable flow at 100Pa	V100Pa	m ³ /h	260
Maximum declared flow at 100Pa	V _{max.rated}	m ³ /h	180
Recommended operating range	V	m ³ /h	50-180
Operating range DIBt	V _{DIBt}	m ³ /h	70 to 140
Operating range Passivhaus at 100Pa	V _{PHI}	m ³ /h	70 to 140
EN 13141-7 reference flow at 50Pa	V _{REF}	m ³ /h	126
Performance			
Thermal efficiency DIBt	η _{DIBt}	%	93.8
Thermal efficiency Passivhaus	η _{PHI}	%	93
Thermal efficiency EN 13141-7 at reference flow	η _{EN}	%	94
Filters in accordance with ISO16890	-	-	ISO Coarse 75% (optional on supply: ePM1>50%)
Filters in accordance with EN779	-	-	G4 (optional on supply: F7)
Installation surrounding temperature range	t _{surr}	°C	+12 to +40
Maximum humidity in extract air at 25°C	RH	%	55
Outdoor temperature range without preheating installed	t _{ODA}	°C	-12* to +45
Outdoor temperature range with preheating installed	t _{ODA}	°C	-15 to +45
Cabinet			
Dimensions (without wall bracket)	w x d x h	mm	600 x 279 x 1122
Spigots/duct connections	Ø	mm	125 – female
Weight	m	kg	34
Heat conductivity – polystyrene insulation	λ	W/mK	0.031
Heat transfer coefficient – polystyrene insulation	U	W/m ² K	<1
Leakage (external and internal) according to EN 13141-7	class		<2% (Class A1)
Drainage hose (included)	Ø	"	1/2
Cabinet colour	RAL	-	9016
Fire classification of the polystyrene insulation	-	-	DIN 4102-1 class B2 EN 13501 class E
Electrical			
Voltage	U	V	230
Maximum power consumption (without/with preheater)	P	W	127/1,027
Frequency	f	Hz	50
Protection class	-	-	IP20

* In order to ensure balanced ventilation, preheater is recommended when outdoor temperature is below -3°C.

Capacity and SPI curves with G4/G4 filters

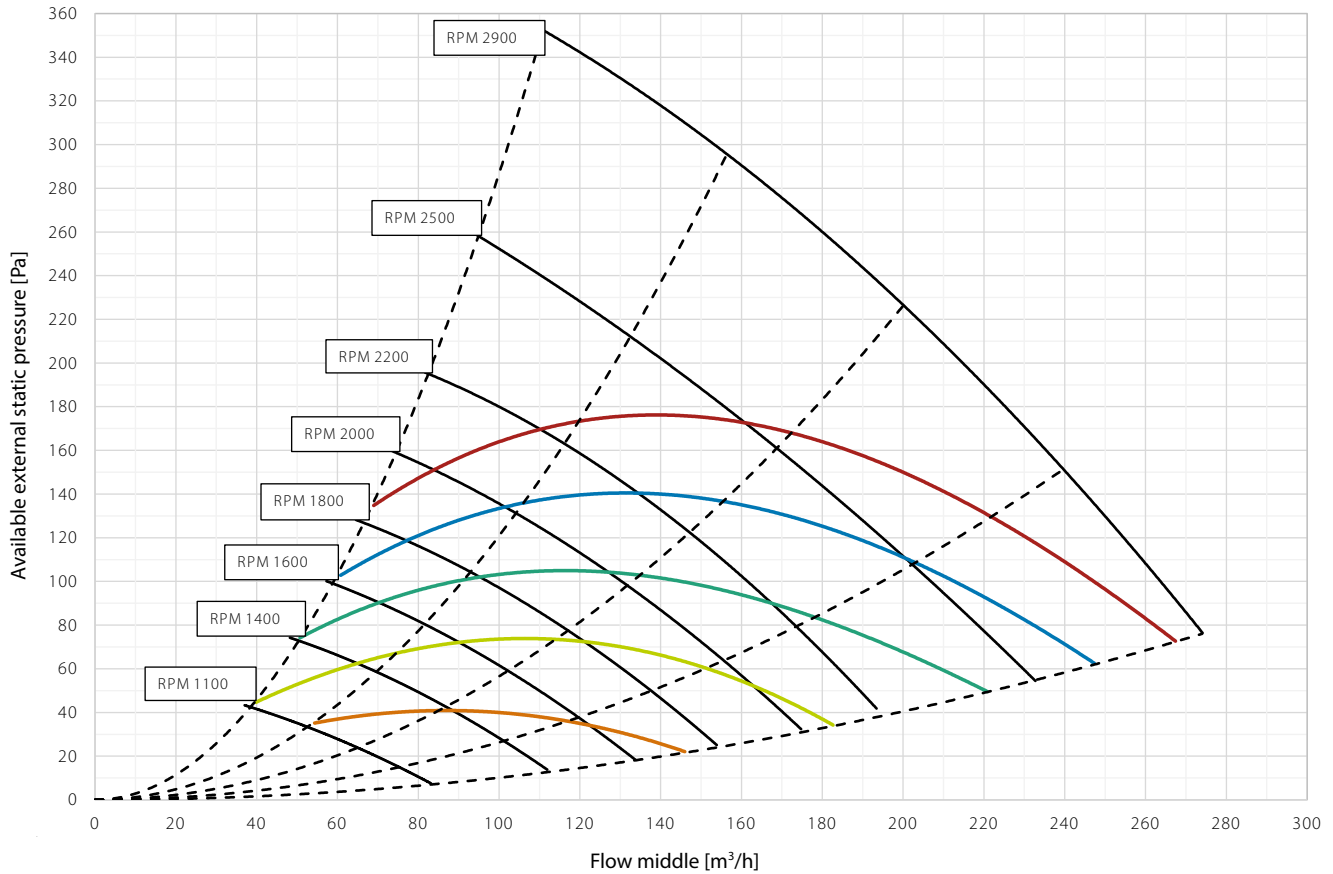

SFP/SPI/SEL*	0.45 W/m ³ /h	0.39 W/m ³ /h	0.33 W/m ³ /h	0.28 W/m ³ /h	0.22 W/m ³ /h
	1620 J/m ³	1400 J/m ³	1200 J/m ³	1000 J/m ³	800 J/m ³
	1.62 W/l/s	1.40 W/l/s	1.20 W/l/s	1.0 W/l/s	0.80 W/l/s

* SFP/SPI/SEL includes power consumption of both fans and the control.

Thermal efficiency curves

Legend

- Thermal efficiency according to EN 13141-7 (dry)
Operational conditions: outdoor air: 7°C, 88% RH; extract air: 20°C, 38% RH
- Thermal efficiency according to EN 13141-7 (with condensation)
Operational conditions: outdoor air: 2°C, 85% RH; extract air: 20°C, 60% RH
- Thermal efficiency according Passivhaus Institut
Operational conditions: outdoor air: 4°C, 94% RH; extract air: 21°C, 30% RH

All values at balanced flow

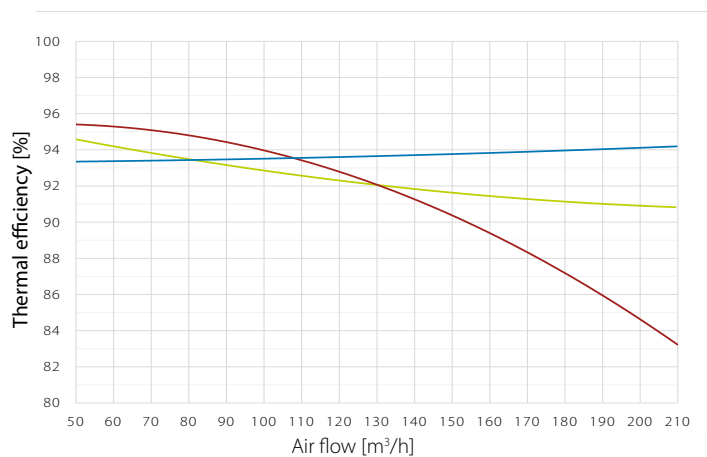

Sound data with G4/G4 filters

Air-volume m ³ /h	Pres. Pa	Measure point	Frequency band sound power L _w (A) dB(A)								Total sound power L _w (A) dB(A)	Sound pres. L _p (A) Standard room*
			63Hz	125Hz	250Hz	500Hz	1000Hz	2000Hz	4000Hz	8000Hz		
80	30	Supply air	23	43	40	42	39	32	20	18	47	
		Extract air	12	26	24	24	16	16	17	18	30	
		Cabinet									30	25
98	50	Supply air	28	41	51	48	44	39	26	18	54	
		Extract air	16	27	31	29	19	16	17	18	35	
		Cabinet									34	29
100	100	Supply air	32	49	56	52	49	44	33	19	59	
		Extract air	19	31	42	33	23	19	17	18	43	
		Cabinet									37	32
126	70	Supply air	31	43	55	52	49	45	33	19	58	
		Extract air	19	30	42	33	23	19	17	18	42	
		Exhaust air	30	43	54	52	47	43	32	18	57	
		Cabinet									40	35
140	100	Supply air	34	46	56	56	52	49	37	21	60	
		Extract air	21	33	44	36	27	21	18	18	45	
		Exhaust air	33	45	56	56	51	47	36	20	60	
		Cabinet									43	38
162		Cabinet								46	41	
198		Cabinet								48	43	

* Standard room = room with 10m² floor, 2.4m ceiling height, mean absorption 0.2.

Dimensions

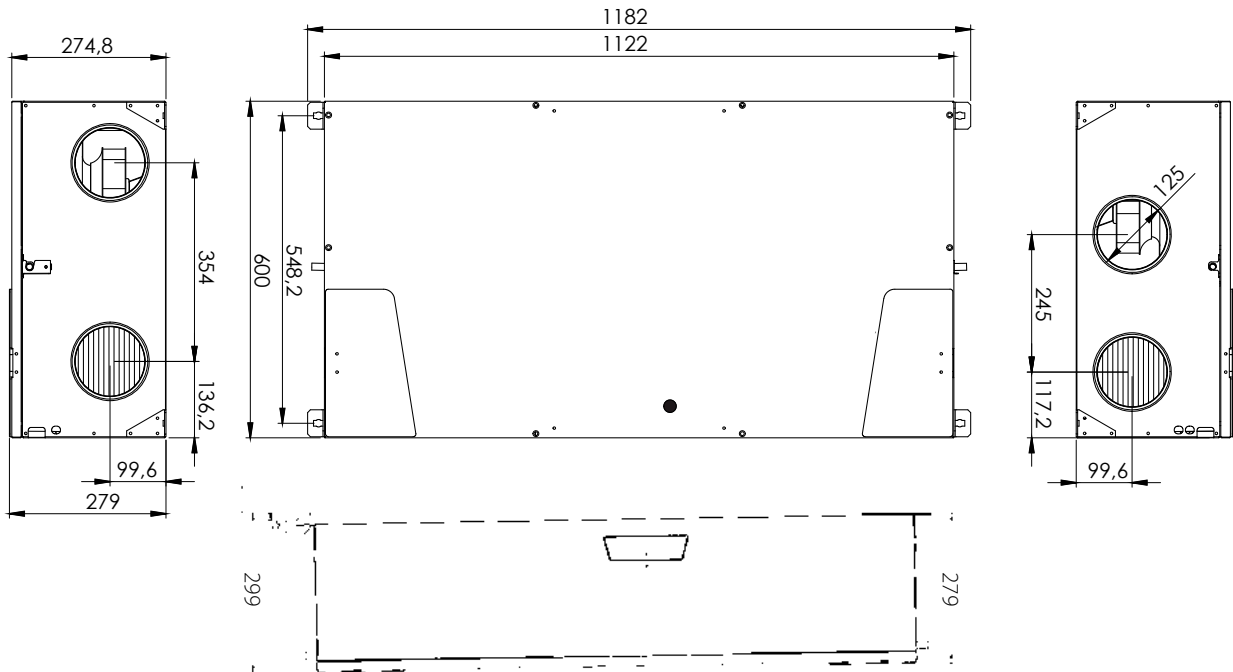

Duct connections

2 set-up in 1 unit, easy change on site

(A) LEFT SET-UP
Factory set-up

(B) RIGHT SET-UP Optional -
easy change on site

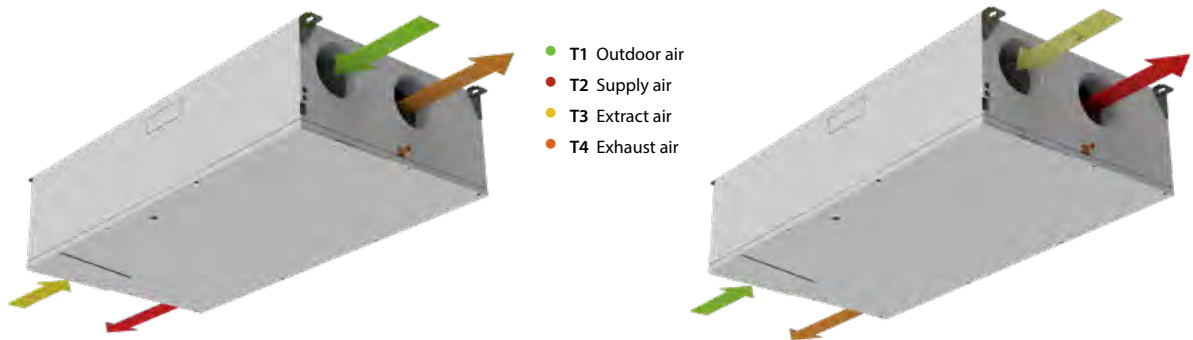

On the HCC 2 it is possible to connect the supply duct to the bottom if the ducts are to run beneath the floor

HCC 260P1



HCC 260P1

The HCC 260_{P1} is a unique and flexible residential ventilation solution. With only 30cm installation headroom it is ideal for installation in suspended ceilings or onto a wall, even hidden inside a closet. The unit can be electronically reversed, meaning that both air flows will be reversed. This allows the same unit type to be mounted with the inside/outside ducts connected to either the right or the left hand side of the unit. Electrical connections can be connected from either the left or the right.

The HCC 260_{P1} has an galvanised metal surface, standard filter resetting capability as well as easy PCB access to connect accessories. Delivered 4 units on a pallet at a time, it also minimises the use of packaging in consideration of the environment.

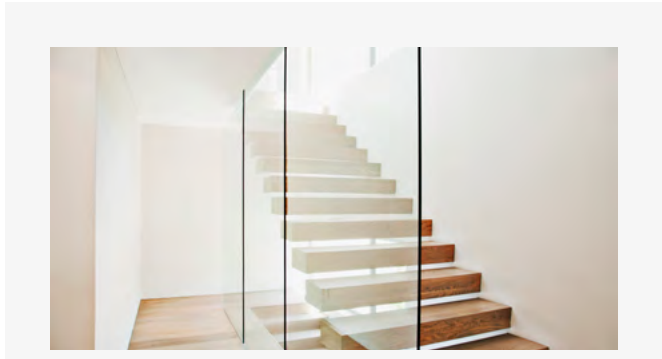

- High efficiency heat recovery – up to 94%
- EC fan motors with low energy consumption (low SPI)
- Only 300mm installation headroom height is required
- Time controlled ventilation level, based on 11 different built-in pre-programmed week programs, reducing power consumption in periods with low ventilation demands
- Summer cooling mode
- Automatic free-cooling features via inbuilt 100% by-pass, including the possibility of increasing the air flow automatically, lets in cool night air following hot days to help maintain a comfortable temperature throughout the day
- Fireplace mode, creating a momentary inside overpressure, to enhance chimney functionality
- Easy-to-install and commissioning solution with built-in air measure ports, for easy balancing with PC Tool
- Electronically left/right fan direction switching, allowing same unit type to adapt any physical installation requirements, regardless of ceiling and wall selection
- TCP/IP ModBus connection, for inter-operation with Building Management System
- Electrical connections can be connected from either the left or the right
- Foil panel on unit

Third party testing and certifications

Code	Description
PHI	Passivhaus certified
ErP	Compliant with EU regulations for Eco-design
Nordic Swan Ecolabel	Listed in the Nordic Swan database for products suitable for Ecolabelled buildings

Specifications	Units		HCC 260P1
Maximum achievable flow at 100Pa	V100Pa	m ³ /h	260
Maximum declared flow at 100Pa	V _{max.rated}	m ³ /h	180
Recommended operating range	V	m ³ /h	50-180
Operating range DIBt	V _{DIBt}	m ³ /h	70 to 140
Operating range Passivhaus at 100Pa	V _{PHI}	m ³ /h	50 to 180
EN 13141-7 reference flow at 50Pa	V _{ref}	m ³ /h	126
Performance			
Thermal efficiency DIBt	η _{DIBt}	%	93.8
Thermal efficiency Passivhaus	η _{PHI}	%	93
Thermal efficiency EN 13141-7 at reference flow	η _{EN}	%	94
Leakage (external and internal) according to EN 13141-7	class		<2% (Class A1)
Filters in accordance with ISO16890	-	-	ISO Coarse 75% (optional on supply: ePM1>50%)
Filters in accordance with EN779	-	-	G4 (optional on supply: F7)
Installation surrounding temperature range	t _{surr}	°C	+12 to +40
Maximum humidity in extract air at 25°C	RH	%	55
Outdoor temperature range without preheating installed	t _{ODA}	°C	-12* to +45
Outdoor temperature range with preheating installed	t _{ODA}	°C	-15 to +45
Cabinet			
Dimensions (without wall bracket)	w x d x h	mm	600 x 279 x 1122
Spigots/duct connections	∅	mm	125 – female
Weight	-	kg	34
Heat conductivity – polystyrene insulation	λ	W/mK	0.031
Heat transfer coefficient – polystyrene insulation	U	W/m ² K	<1
Drainage hose (accessory)	∅		1/2"
Cabinet colour	-	-	galvanised metal grey
Fire classification of the polystyrene insulation	class	-	DIN 4102-1 class B2 EN 13501 class E
Electrical			
Voltage	U	V	230
Maximum power consumption (without/with preheater)	P	W	127/1,027
Frequency	f	Hz	50
Protection class	-	-	IP20

* In order to ensure balanced ventilation, preheater is recommended when outdoor temperature is below -3°C.

Capacity and SPI curves with G4/G4 filters

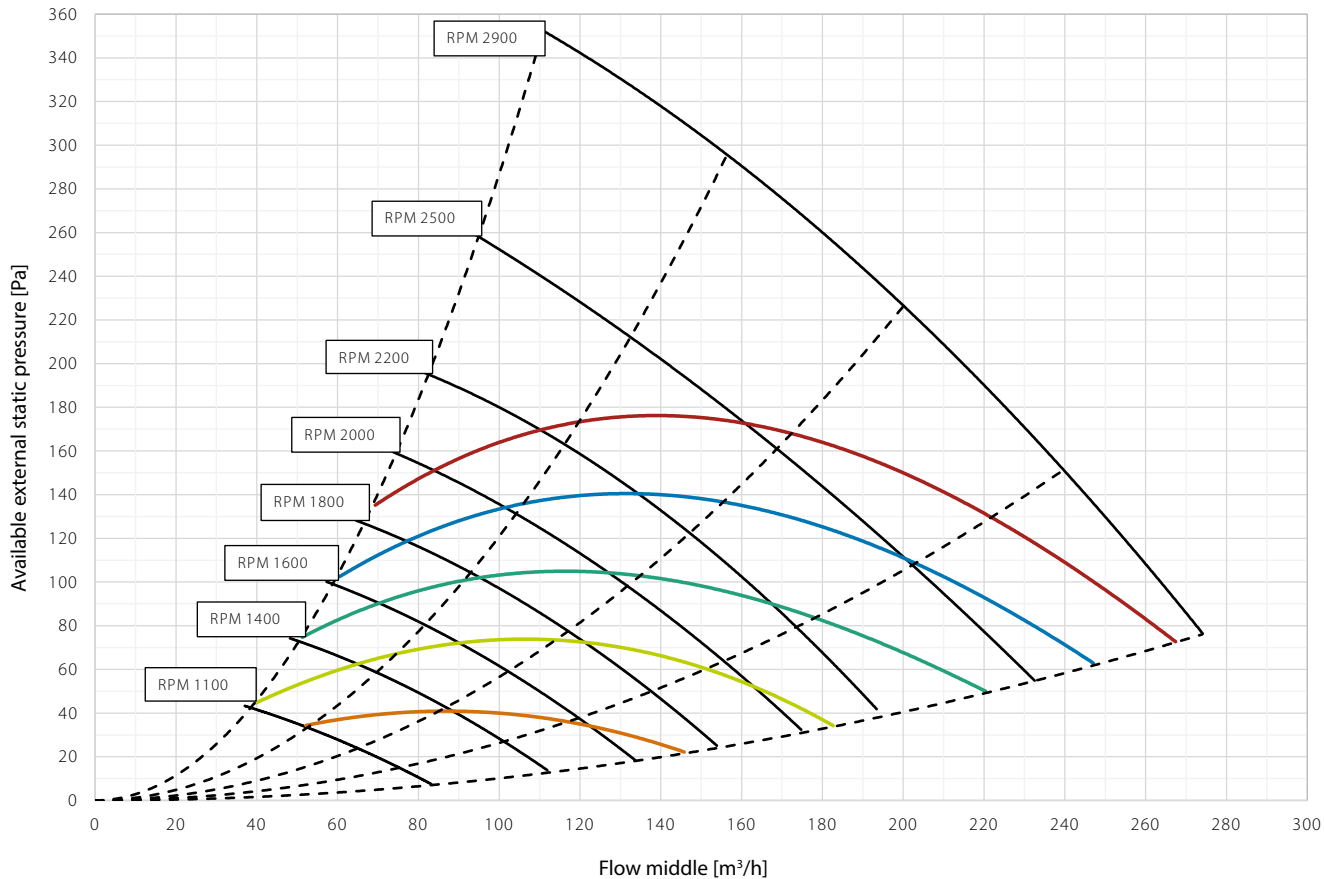

	0.45 W/m³/h	0.39 W/m³/h	0.33 W/m³/h	0.28 W/m³/h	0.22 W/m³/h
SFP/SPI/SEL*	1620 J/m³	1400 J/m³	1200 J/m³	1000 J/m³	800 J/m³
	1.62 W/l/s	1.40 W/l/s	1.20 W/l/s	1.0 W/l/s	0.80 W/l/s

* SFP/SPI/SEL includes power consumption of both fans and the control.

Thermal efficiency curves

Legend

- Thermal efficiency according to EN 13141-7 (dry)
Operational conditions: outdoor air: 7°C, 88% RH; extract air: 20°C, 38% RH
- Thermal efficiency according to EN 13141-7 (with condensation)
Operational conditions: outdoor air: 2°C, 85% RH; extract air: 20°C, 60% RH
- Thermal efficiency according Passivhaus Institut
Operational conditions: outdoor air: 4°C, 94% RH; extract air: 21°C, 30% RH

All values at balanced flow

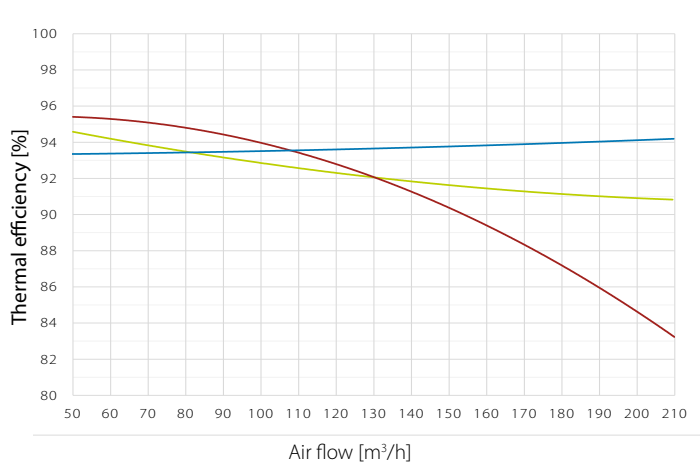

Sound data with G4/G4 filters

Air-volume m ³ /h	Pres. Pa	Measure point	Frequency band sound power L _w (A) dB(A)								Total sound power L _w (A) dB(A)	Sound pres. L _p (A) Standard room*
			63Hz	125Hz	250Hz	500Hz	1000Hz	2000Hz	4000Hz	8000Hz		
80	30	Supply air	23	43	40	42	39	32	20	18	47	
		Extract air	12	26	24	24	16	16	17	18	30	
		Cabinet									30	25
98	50	Supply air	28	41	51	48	44	39	26	18	54	
		Extract air	16	27	31	29	19	16	17	18	35	
		Cabinet									34	29
100	100	Supply air	32	49	56	52	49	44	33	19	59	
		Extract air	19	31	42	33	23	19	17	18	43	
		Cabinet									37	32
126	70	Supply air	31	43	55	52	49	45	33	19	58	
		Extract air	19	30	42	33	23	19	17	18	42	
		Exhaust air	30	43	54	52	47	43	32	18	57	
		Cabinet									40	35
140	100	Supply air	34	46	56	56	52	49	37	21	60	
		Extract air	21	33	44	36	27	21	18	18	45	
		Exhaust air	33	45	56	56	51	47	36	20	60	
		Cabinet									43	38
162		Cabinet								46	41	
198		Cabinet								48	43	

* Standard room = room with 10m² floor, 2.4m ceiling height, mean absorption 0.2.

Dimensions

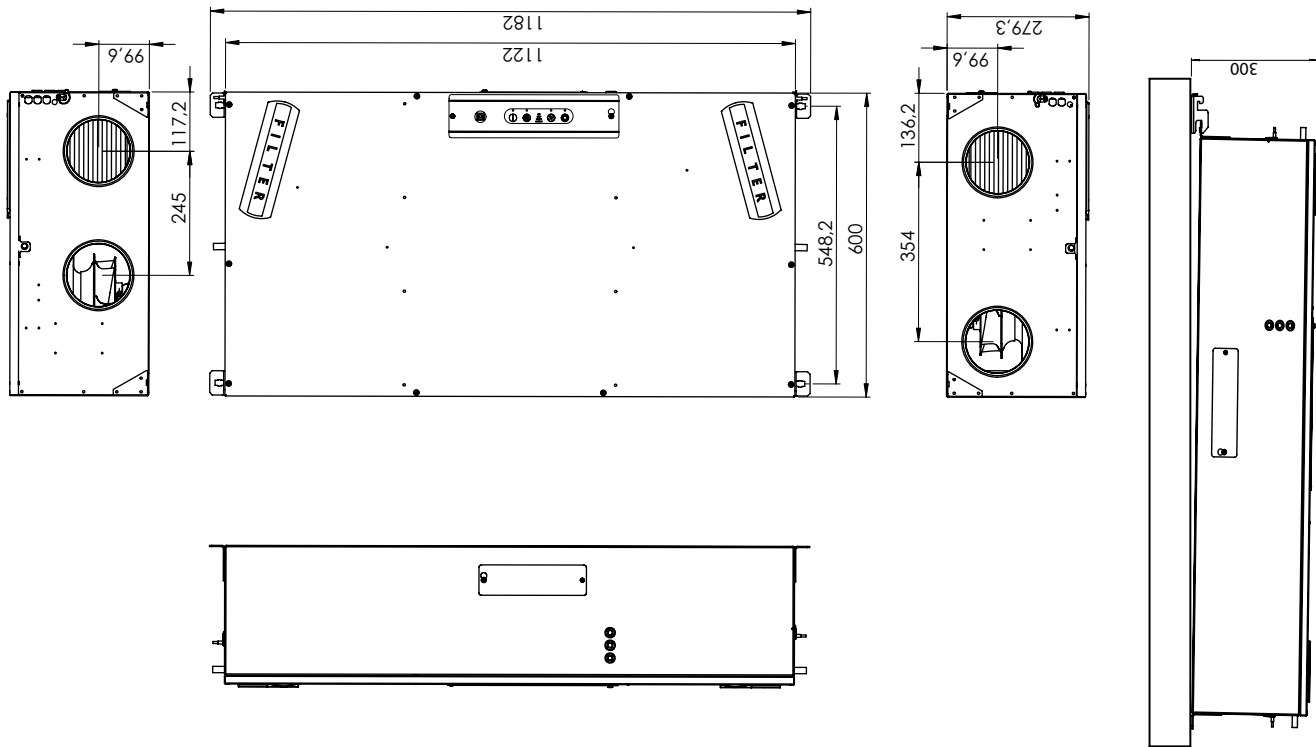

REVIT

Revit files are available for free on request. Contact your local supplier or Dantherm for access.

Duct connections

2 set-up in 1 unit, easy change on site

(A) LEFT SET-UP
Factory set-up

(B) RIGHT SET-UP Optional -
easy change on site

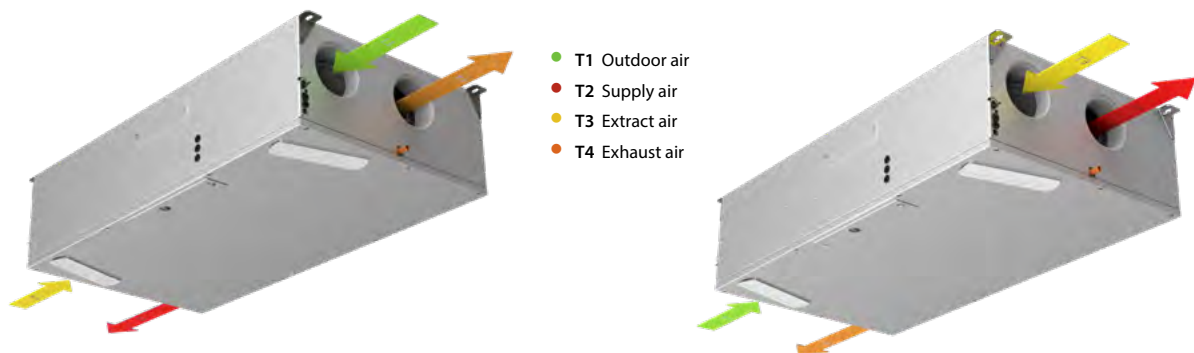

HCC 360E1



HCC 360E1

The HCC 360E1 is a unique and flexible residential ventilation solution. With only 30cm installation headroom it is ideal for installation in suspended ceilings or onto a wall, even hidden inside a closet. The unit can be electronically reversed, meaning that both air flows will be reversed. This allows the same unit type to be mounted with the inside/outside ducts connected to either the right or the left hand side of the unit. Electrical connections can be connected from either the left or the right.

The HCC 360E1's surface is in galvanised metal and the units will be delivered on pallets of four to reduce packaging and shipping costs. This makes it ideal for large-scale projects.



- High efficiency heat recovery – up to 85%
- EC fan motors with low energy consumption (low SPI)
- Only 300mm installation headroom height is required
- Time controlled ventilation level, based on 11 different built-in pre-programmed week programs, reducing power consumption in periods with low ventilation demands
- Summer cooling mode
- Automatic free-cooling features via inbuilt 100% by-pass, including the possibility of increasing the air flow automatically, lets in cool night air following hot days to help maintain a comfortable temperature throughout the day
- Fireplace mode, creating a momentary inside overpressure, to enhance chimney functionality
- Easy-to-install and commissioning solution with built in air measure ports, for easy balancing with PC Tool
- Electronically left/right fan direction switching, allowing same unit type to adapt any physical installation requirements, regardless of ceiling and wall selection
- TCP/IP ModBus connection, for inter-operation with Building Management System
- Electrical connections can be connected from either the left or the right
- Two humidity sensors to facilitate switching from left/right setup
- Prepared for easy mounting of condensate pump

Third party testing and certifications

Code	Description
ErP	Compliant with EU regulations for Eco-design
Nordic Swan Ecolabel	Listed in the Nordic Swan database for products suitable for Ecolabelled buildings

Specifications	Units		HCC 360 _{E1}
Maximum achievable flow at 100Pa	V100Pa	m ³ /h	360
Maximum declared flow at 100Pa	V _{max.rated}	m ³ /h	180
Recommended operating range	V	m ³ /h	50-180
EN 13141-7 reference flow at 50Pa	V _{ref}	m ³ /h	126
Performance			
Thermal efficiency EN 13141-7 at reference flow	η_{EN}	%	80
Leakage (external and internal) according to EN 13141-7	class		<2% (Class A1)
Filters in accordance with ISO16890	-	-	ISO Coarse 75% (optional on supply: ePM1>50%)
Filters in accordance with EN779	-	-	G4 (optional on supply: F7)
Installation surrounding temperature range	t _{surr}	°C	+12 to +40
Maximum humidity in extract air at 25°C	RH	%	55
Outdoor temperature range without preheating installed	t _{ODA}	°C	-12* to +45
Outdoor temperature range with preheating installed	t _{ODA}	°C	-15 to +45
Cabinet			
Dimensions (without wall bracket)	w x d x h	mm	600 x 279 x 1122
Spigots/duct connections	Ø	mm	125 – female
Weight	-	kg	34
Heat conductivity – polystyrene insulation	λ	W/mK	0.031
Heat transfer coefficient – polystyrene insulation	U	W/(m ² K)	<1
Drainage hose (accessory)	Ø	"	1/2
Cabinet colour	RAL	-	galvanised metal grey
Fire classification of the polystyrene insulation	-	-	DIN 4102-1 class B2 EN 13501 class E
Electrical			
Voltage	U	V	230
Maximum power consumption (without/with preheater)	P	W	161/1,061
Frequency	f	Hz	50
Protection class	-	-	IP20

* In order to ensure balanced ventilation, preheater is recommended when outdoor temperature is below -5°C.

Capacity and SPI curves with G4/G4 filters

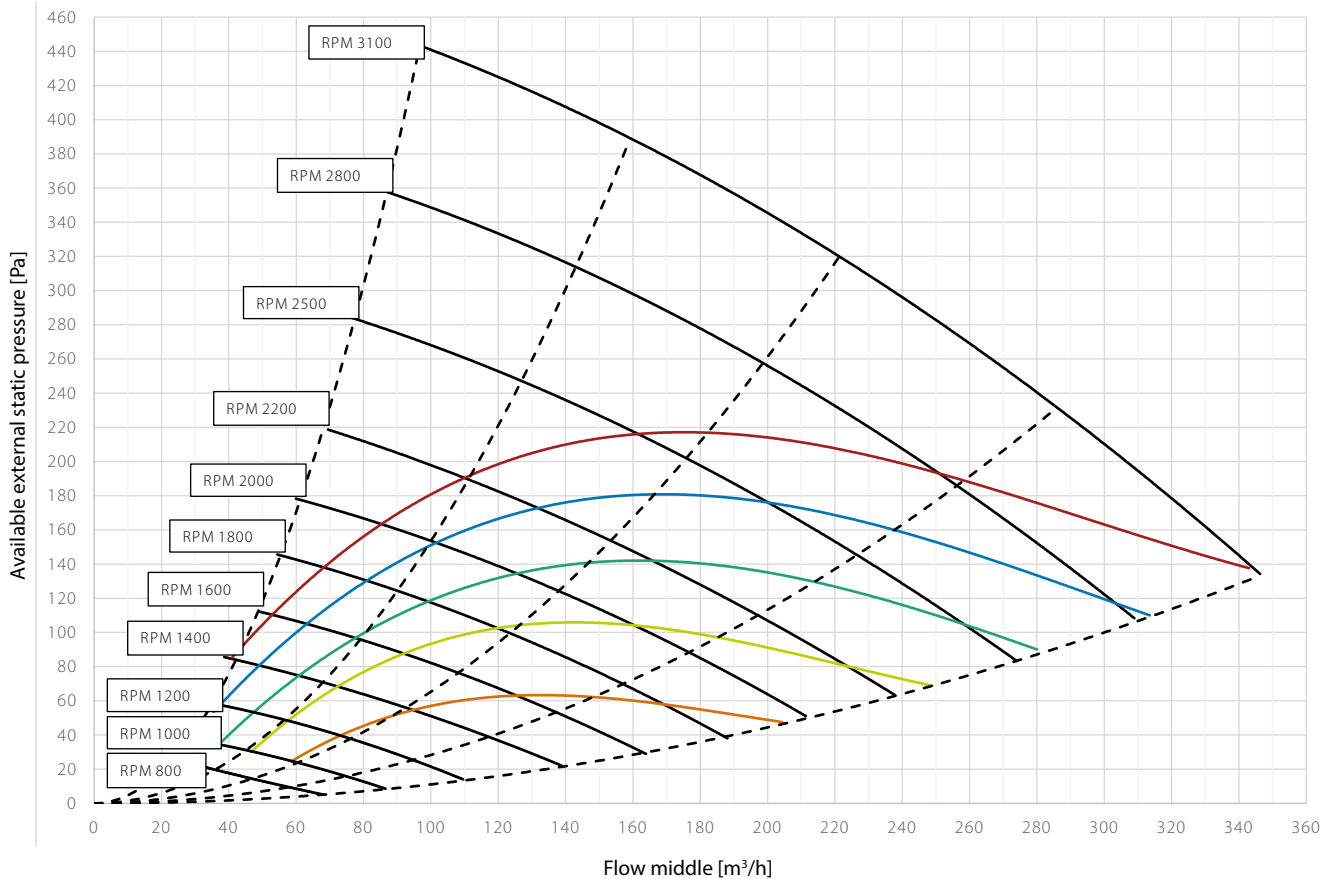

SFP/SPI/SEL*	0.45 W/m³/h	0.39 W/m³/h	0.33 W/m³/h	0.28 W/m³/h	0.22 W/m³/h
	1620 J/m³	1400 J/m³	1200 J/m³	1000 J/m³	800 J/m³
	1.62 W/l/s	1.40 W/l/s	1.20 W/l/s	1.0 W/l/s	0.80 W/l/s

* SFP/SPI/SEL includes power consumption of both fans and the control.

Thermal efficiency curves

Legend

- Thermal efficiency according to EN 13141-7 (dry)
Operational conditions: outdoor air: 7°C, 70% RH; extract air: 20°C, 38% RH
- Humidity efficiency according to EN 13141-7 (with condensation)
Operational conditions: outdoor air: 2°C, 88% RH; extract air: 20°C, 60% RH

All values at balanced flow

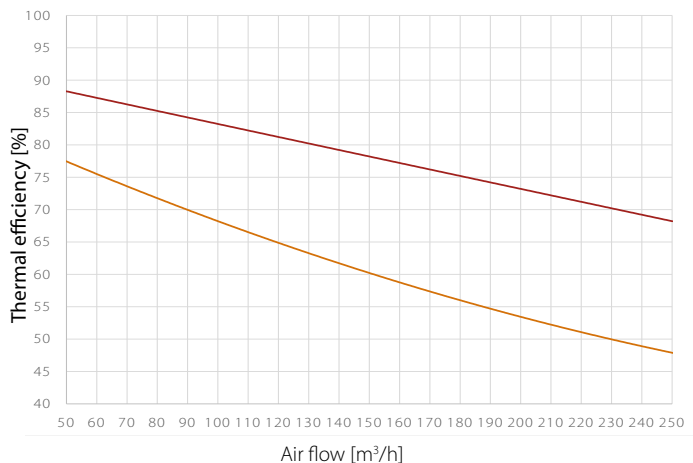

Sound power level (Lw) – ducts

RPM	Duct	[dB(A)]								
		63Hz	125Hz	250Hz	500Hz	1kHz	2kHz	4kHz	8kHz	Total
1400	supply/exhaust	29.7	44.1	48.1	48.4	46.6	43.8	33.3	18.4	54
	extract/outdoor	25.1	33.2	38.3	36.9	21.9	15.9	-	-	42
1600	supply/exhaust	31.7	44.1	58.0	52.1	50.0	47.3	37.5	23.4	60
	extract/outdoor	27.5	33.3	46.6	45.2	25.7	19.2	-	-	49
1800	supply/exhaust	33.8	44.2	60.3	54.6	52.9	50.2	40.8	27.8	62
	extract/outdoor	30.0	33.5	46.6	46.1	29.1	22.3	-	-	50
2000	supply/exhaust	36.0	44.4	64.4	56.5	55.4	52.8	43.9	31.5	66
	extract/outdoor	32.8	35.0	50.9	46.3	32.0	25.4	13.1	-	52
2200	supply/exhaust	37.3	45.8	64.4	59.9	57.7	55.2	46.7	35.0	67
	extract/outdoor	34.1	37.1	51.0	48.4	34.7	28.2	16.2	-	53
2500	supply/exhaust	39.9	48.0	64.5	62.5	61.1	58.8	50.2	39.8	68
	extract/outdoor	36.7	39.6	52.0	49.3	38.2	32.1	20.8	-	54
2800	supply/exhaust	42.4	50.2	67.9	65.6	64.1	61.8	53.2	43.3	72
	extract/outdoor	39.3	42.2	54.5	55.1	41.7	35.5	24.8	13.3	58
3100	supply/exhaust	54.5	52.5	68.7	70.5	67.6	64.7	56.0	46.3	74
	extract/outdoor	47.9	44.4	55.3	64.8	45.6	38.6	28.4	17.6	65

Sound pressure level (Lp) – cabinet**1m distance**

RPM	[dB(A)]								Total
	63Hz	125Hz	250Hz	500Hz	1kHz	2kHz	4kHz	8kHz	
1000	-	-	9.9	17.8	18.1	20.1	15.7	-	24
1200	-	-	11.0	19.5	19.1	20.2	15.7	-	25
1400	-	-	13.1	22.6	19.1	20.2	15.7	-	26
1500	-	-	18.0	25.0	21.0	20.4	15.8	-	28
1600	-	-	24.0	26.7	21.0	20.6	15.9	-	30
1700	-	-	26.2	29.2	21.4	21.0	16.0	-	32
1800	-	-	26.3	30.2	21.4	21.5	16.1	-	33
1900	-	-	27.0	31.7	22.9	21.8	16.3	-	34
2000	-	-	28.0	32.0	25.3	22.0	16.4	-	34
2100	-	-	29.5	32.9	25.4	22.7	16.9	-	35
2200	-	-	30.0	33.0	25.6	23.0	18.4	-	36
2300	-	-	30.4	34.8	26.3	23.4	19.0	-	37
2500	-	-	32.0	36.3	28.4	25.5	19.5	10.0	38
2700	-	-	36.1	40.8	30.5	27.5	19.7	11.1	43
2800	-	-	36.5	41.7	32.6	28.5	21.4	12.9	43
2900	-	-	31.7	45.3	32.7	29.0	22.2	13.3	46
3100	-	11.2	40.0	47.2	34.4	31.1	24.9	15.6	48

2m distance

RPM	[dB(A)]								Total
	63Hz	125Hz	250Hz	500Hz	1kHz	2kHz	4kHz	8kHz	
1000	-	-	5.6	17.8	18.1	18.2	14.1	-	23
1200	-	-	6.9	19.5	19.1	18.2	14.8	-	24
1400	-	-	10.6	21.1	19.1	19.3	15.0	-	25
1500	-	-	15.8	24.1	19.2	19.3	15.2	-	27
1600	-	-	17.7	25.0	20.7	20.0	15.6	-	28
1700	-	-	19.8	26.0	21.0	20.1	16.0	-	29
1800	-	-	20.0	28.3	21.0	20.2	16.1	-	30
1900	-	-	21.0	31.2	22.8	20.2	16.2	-	32
2000	-	-	22.0	31.5	22.8	20.5	16.4	-	33
2100	-	-	23.5	32.9	23.6	20.5	16.7	-	34
2200	-	-	23.5	33.0	25.0	22.4	18.4	-	34
2300	-	-	24.0	33.6	25.0	22.4	19.0	-	35
2500	-	-	29.0	34.7	26.1	24.3	19.5	-	37
2700	-	-	30.9	38.7	27.7	26.0	19.7	-	40
2800	-	-	31.0	39.0	28.4	26.1	20.9	-	40
2900	-	-	31.0	43.0	29.3	26.4	21.0	-	44
3100	-	6.7	31.0	45.3	31.4	28.1	21.9	10.6	46

Dimensions

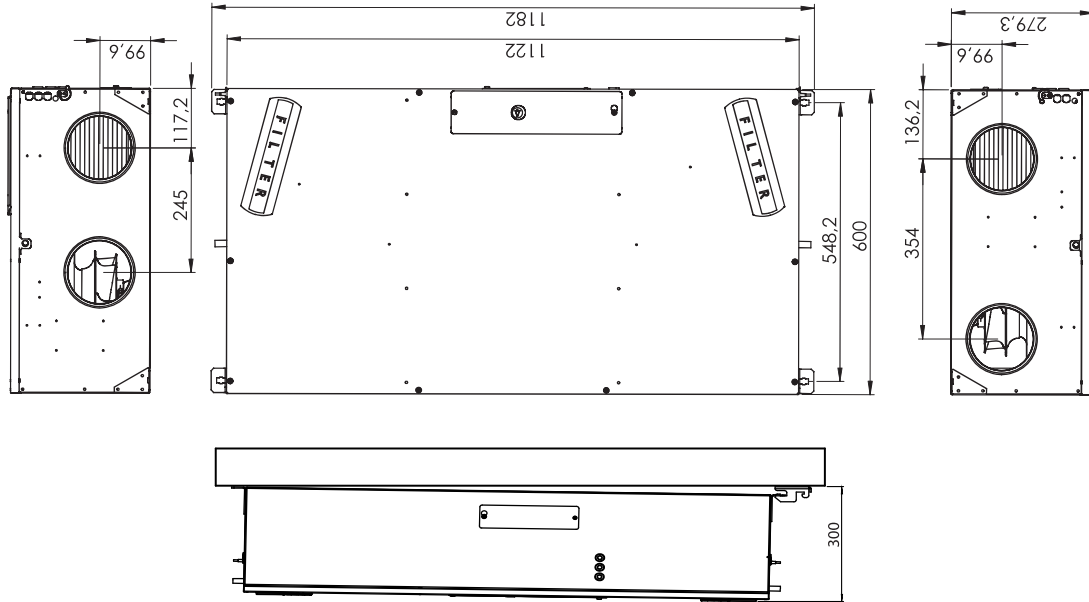

REVIT Revit files are available for free on request. Contact your local supplier or Dantherm for access.

Duct connections

2 set-up in 1 unit, easy change on site

(A) LEFT SET-UP
Factory set-up

(B) RIGHT SET-UP Optional -
easy change on site

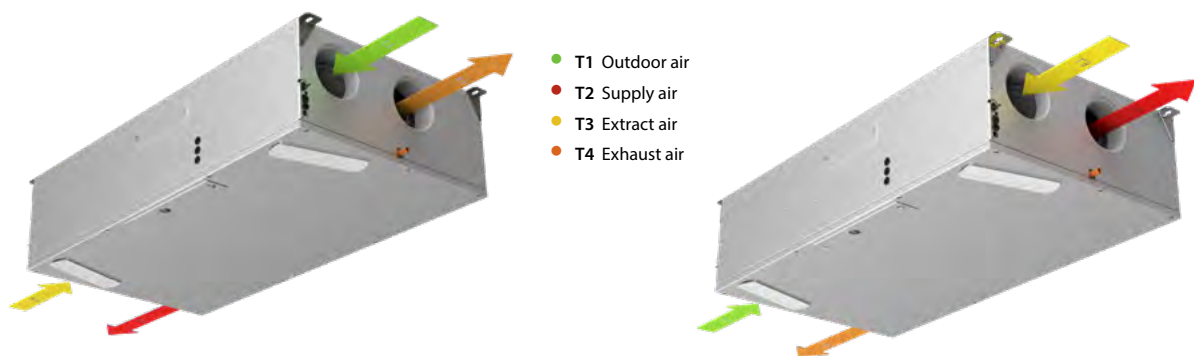

HCC 360P2



HCC 360P2

The HCC 360_{P2} is a unique and flexible residential ventilation solution. With only 30cm installation headroom it is ideal for installation in suspended ceilings or onto a wall, even hidden inside a closet. The unit can be electronically reversed, meaning that both air flows will be reversed. This allows the same unit type to be mounted with the inside/outside ducts connected to either the right or the left hand side of the unit. Electrical connections can be connected from either the left or the right.

The HCC 360_{P2}'s surface is in galvanised metal and the units will be delivered on pallets of four to reduce packaging and shipping costs. This makes it ideal for large-scale projects.



- High efficiency heat recovery – up to 85%
- EC fan motors with low energy consumption (low SPI)
- Only 300mm installation headroom height is required
- Time controlled ventilation level, based on 11 different built-in pre-programmed week programs, reducing power consumption in periods with low ventilation demands
- Summer cooling mode
- Automatic free-cooling features via inbuilt 100% by-pass, including the possibility of increasing the air flow automatically, lets in cool night air following hot days to help maintain a comfortable temperature throughout the day
- Fireplace mode, creating a momentary inside overpressure, to enhance chimney functionality
- Easy-to-install and commissioning solution with built in air measure ports, for easy balancing with PC Tool
- Electronically left/right fan direction switching, allowing same unit type to adapt any physical installation requirements, regardless of ceiling and wall selection
- TCP/IP ModBus connection, for inter-operation with Building Management System
- Electrical connections can be connected from either the left or the right
- Two humidity sensors to facilitate switching from left/right setup
- Prepared for easy mounting of condensate pump

Third party testing and certifications

Code	Description
ErP	Compliant with EU regulations for Eco-design
Nordic Swan Ecolabel	Listed in the Nordic Swan database for products suitable for Ecolabelled buildings

Specifications	Units		HCC 360 _{P2}
Maximum achievable flow at 100Pa	V100Pa	m ³ /h	360
Maximum declared flow at 100Pa	V _{max.rated}	m ³ /h	220
Recommended operating range	V	m ³ /h	50-220
EN 13141-7 reference flow at 50Pa	V _{ref}	m ³ /h	154
Performance			
Thermal efficiency EN 13141-7 at reference flow	η_{EN}	%	88
Leakage (external and internal) according to EN 13141-7	class		<2% (Class A1)
Filters in accordance with ISO16890	-	-	ISO Coarse 75% (optional on supply: ePM1>50%)
Filters in accordance with EN779	-	-	G4 (optional on supply: F7)
Installation surrounding temperature range	t _{surr}	°C	+12 to +40
Maximum humidity in extract air at 25°C	RH	%	55
Outdoor temperature range without preheating installed	t _{ODA}	°C	-12* to +45
Outdoor temperature range with preheating installed	t _{ODA}	°C	-15 to +45
Cabinet			
Dimensions (without wall bracket)	w x d x h	mm	600 x 279 x 1122
Spigots/duct connections	Ø	mm	125 – female
Weight	-	kg	34
Heat conductivity – polystyrene insulation	λ	W/mK	0.031
Heat transfer coefficient – polystyrene insulation	U	W/m ² K	U<1
Drainage hose (accessory)	Ø	"	1/2
Cabinet colour	RAL	-	galvanised metal grey
Fire classification of the polystyrene insulation	-	-	DIN 4102-1 class B2 EN 13501 class E
Electrical			
Voltage	U	V	230
Maximum power consumption (without/with preheater)	P	W	161/1,061
Frequency	f	Hz	50
Protection class	-	-	IP20

* In order to ensure balanced ventilation, preheater is recommended when outdoor temperature is below -3°C.

Capacity and SPI curves with G4/G4 filters

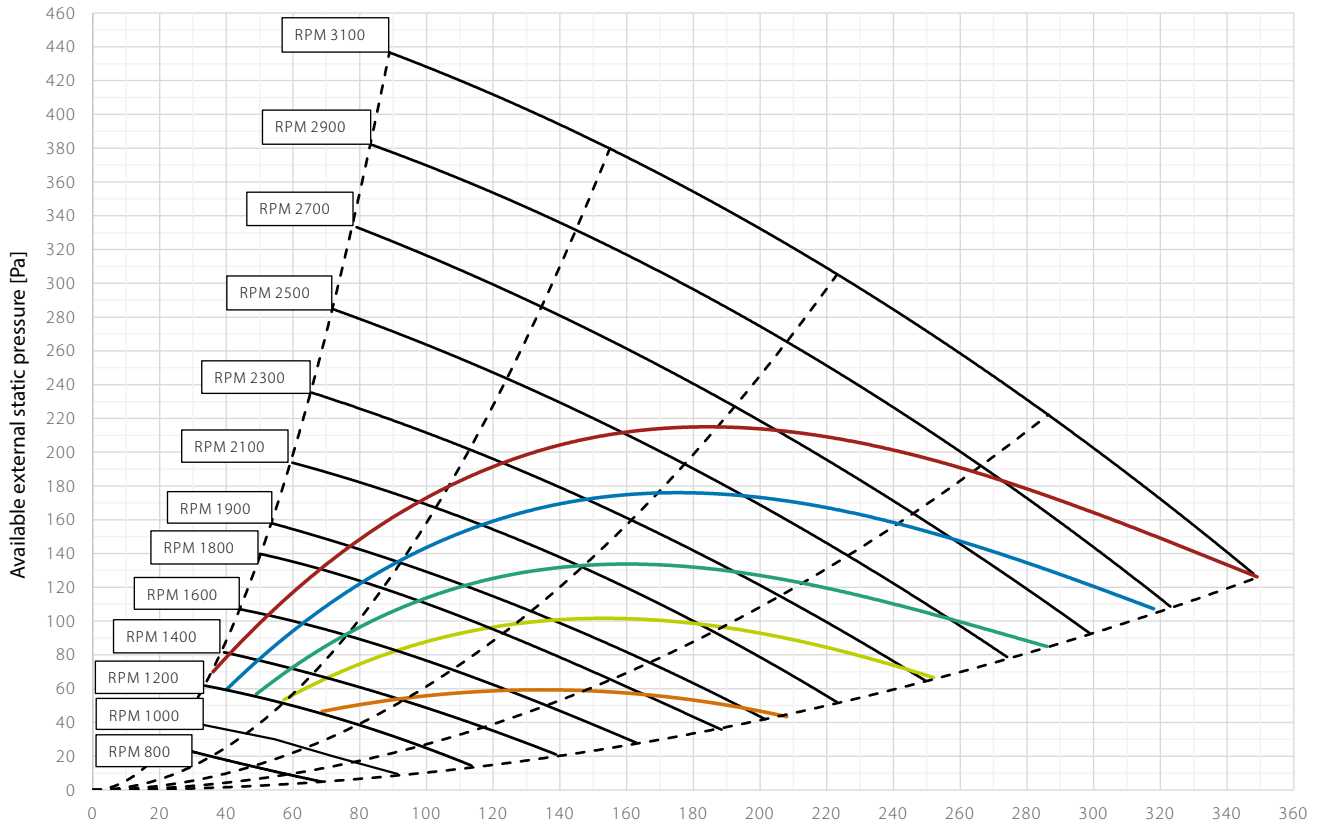

SFP/SPI/SEL*	0.45 W/m ³ /h	0.39 W/m ³ /h	0.33 W/m ³ /h	0.28 W/m ³ /h	0.22 W/m ³ /h
	1620 J/m ³	1400 J/m ³	1200 J/m ³	1000 J/m ³	800 J/m ³
	1.62 W/l/s	1.40 W/l/s	1.20 W/l/s	1.0 W/l/s	0.80 W/l/s

* SFP/SPI/SEL includes power consumption of both fans and the control.

Thermal efficiency curves

Legend

- Thermal efficiency according to EN 13141-7 (dry)
Operational conditions: outdoor air: 7°C, 88% RH; extract air: 20°C, 38% RH
All values at balanced flow

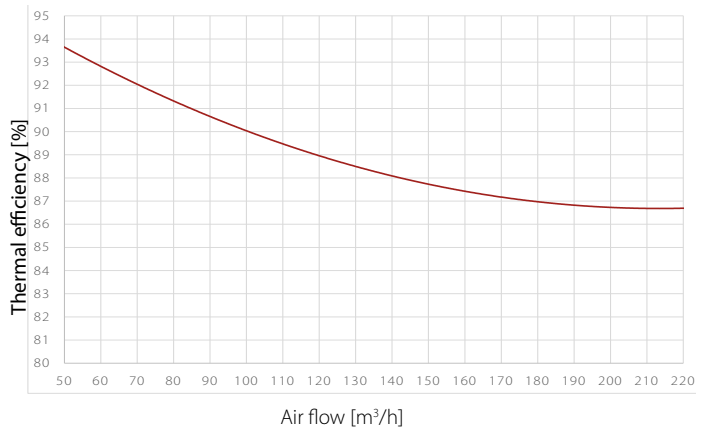

Sound power level (L_w) – ducts

RPM	Duct	[dB(A)]								
		63Hz	125Hz	250Hz	500Hz	1kHz	2kHz	4kHz	8kHz	Total
1000	supply/exhaust	21.3	34.5	38.1	37.2	34.3	30.7	17.6	-	43
	extract/outdoor	20.2	28.7	25.8	27.9	14.1	-	-	-	33
1200	supply/exhaust	24.4	44.1	40.7	41.5	39.1	36.2	24.5	-	48
	extract/outdoor	20.8	35.2	29.1	31.6	16.9	12.5	-	-	38
1400	supply/exhaust	27.7	44.1	44.5	45.7	43.2	40.4	30.1	15.5	51
	extract/outdoor	24.7	37.0	34.6	35.3	21.4	16.3	-	-	41
1500	supply/exhaust	34.5	45.1	47.8	48.1	44.8	42.9	33.4	18.5	53
	extract/outdoor	25.5	37.2	36.1	37.7	23.0	17.7	-	-	42
1700	supply/exhaust	38.4	45.2	52.3	51.5	48.3	46.8	37.3	23.5	57
	extract/outdoor	28.0	37.4	41.5	42.6	26.5	21.2	-	-	46
1900	supply/exhaust	38.5	45.3	58.4	54.7	52.1	49.5	40.9	28.1	61
	extract/outdoor	31.2	37.6	46.3	45.5	30.8	24.9	10.8	-	49
2100	supply/exhaust	38.6	45.4	61.0	56.7	53.7	51.8	43.5	32.0	63
	extract/outdoor	33.2	37.8	48.6	45.5	34.0	27.7	14.8	-	51
2300	supply/exhaust	38.7	45.5	61.0	61.3	57.8	55.1	46.7	36.1	66
	extract/outdoor	34.9	38.0	49.0	46.9	36.5	30.6	17.6	-	52
2500	supply/exhaust	38.9	46.6	61.8	62.1	59.6	57.4	49.0	38.8	67
	extract/outdoor	36.2	38.2	52.3	48.4	38.9	33.3	20.7	-	54
2700	supply/exhaust	40.5	48.6	66.0	64.1	61.7	59.6	51.1	41.4	70
	extract/outdoor	38.9	39.8	61.7	52.3	41.3	35.9	23.6	12.4	62
2900	supply/exhaust	42.3	50.5	68.8	67.1	64.4	61.7	53.2	43.7	72
	extract/outdoor	40.1	41.5	64.4	59.7	44.1	38.1	26.2	15.0	66
3100	supply/exhaust	54.9	51.4	69.0	71.4	68.5	63.7	55.2	45.7	75
	extract/outdoor	49.1	42.7	56.4	67.3	47.9	40.1	28.6	17.5	68

Sound pressure level (Lp) – cabinet**1m distance**

RPM	[dB(A)]								Total
	63Hz	125Hz	250Hz	500Hz	1kHz	2kHz	4kHz	8kHz	
1000	-	-	9.9	17.8	18.1	20.1	15.7	-	24
1200	-	-	11.0	19.5	19.1	20.2	15.7	-	25
1400	-	-	13.1	22.6	19.1	20.2	15.7	-	26
1500	-	-	18.0	25.0	21.0	20.4	15.8	-	28
1600	-	-	24.0	26.7	21.0	20.6	15.9	-	30
1700	-	-	26.2	29.2	21.4	21.0	16.0	-	32
1800	-	-	26.3	30.2	21.4	21.5	16.1	-	33
1900	-	-	27.0	31.7	22.9	21.8	16.3	-	34
2000	-	-	28.0	32.0	25.3	22.0	16.4	-	34
2100	-	-	29.5	32.9	25.4	22.7	16.9	-	35
2200	-	-	30.0	33.0	25.6	23.0	18.4	-	36
2300	-	-	30.4	34.8	26.3	23.4	19.0	-	37
2500	-	-	32.0	36.3	28.4	25.5	19.5	10.0	38
2700	-	-	36.1	40.8	30.5	27.5	19.7	11.1	43
2800	-	-	36.5	41.7	32.6	28.5	21.4	12.9	43
2900	-	-	31.7	45.3	32.7	29.0	22.2	13.3	46
3100	-	11.2	40.0	47.2	34.4	31.1	24.9	15.6	48

2m distance

RPM	[dB(A)]								Total
	63Hz	125Hz	250Hz	500Hz	1kHz	2kHz	4kHz	8kHz	
1000	-	-	5.6	17.8	18.1	18.2	14.1	-	23
1200	-	-	6.9	19.5	19.1	18.2	14.8	-	24
1400	-	-	10.6	21.1	19.1	19.3	15.0	-	25
1500	-	-	15.8	24.1	19.2	19.3	15.2	-	27
1600	-	-	17.7	25.0	20.7	20.0	15.6	-	28
1700	-	-	19.8	26.0	21.0	20.1	16.0	-	29
1800	-	-	20.0	28.3	21.0	20.2	16.1	-	30
1900	-	-	21.0	31.2	22.8	20.2	16.2	-	32
2000	-	-	22.0	31.5	22.8	20.5	16.4	-	33
2100	-	-	23.5	32.9	23.6	20.5	16.7	-	34
2200	-	-	23.5	33.0	25.0	22.4	18.4	-	34
2300	-	-	24.0	33.6	25.0	22.4	19.0	-	35
2500	-	-	29.0	34.7	26.1	24.3	19.5	-	37
2700	-	-	30.9	38.7	27.7	26.0	19.7	-	40
2800	-	-	31.0	39.0	28.4	26.1	20.9	-	40
2900	-	-	31.0	43.0	29.3	26.4	21.0	-	44
3100	-	6.7	31.0	45.3	31.4	28.1	21.9	10.6	46

Dimensions

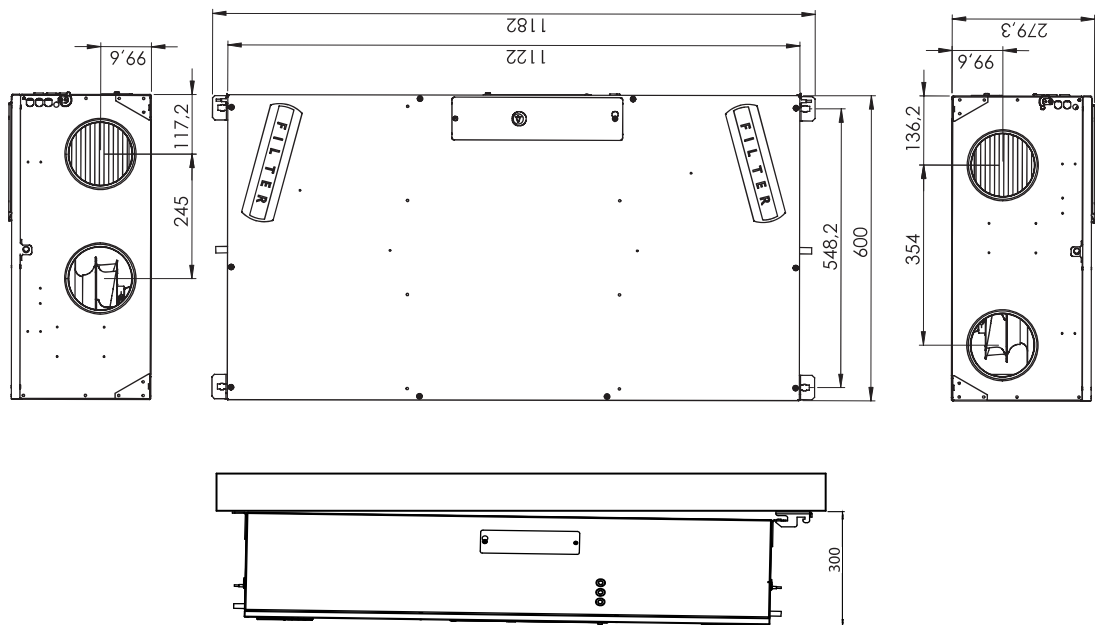

REVIT Revit files are available for free on request. Contact your local supplier or Dantherm for access.

Duct connections

2 set-up in 1 unit, easy change on site

(A) LEFT SET-UP
Factory set-up

(B) RIGHT SET-UP Optional -
easy change on site

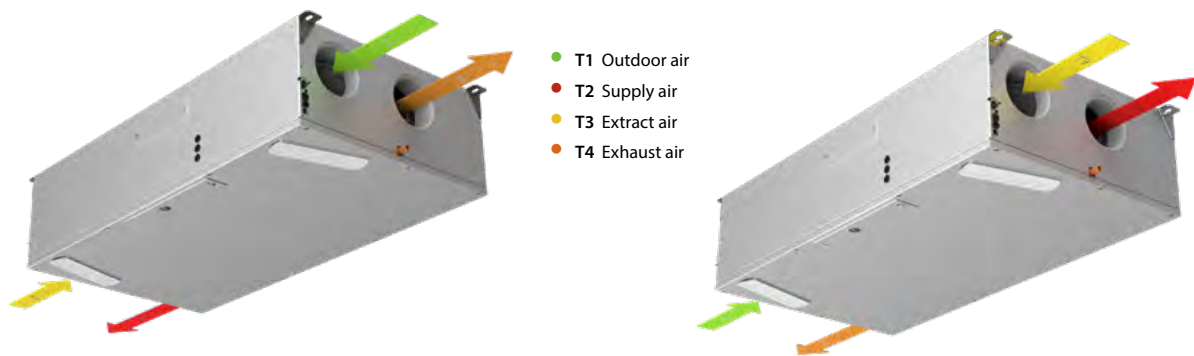



Function

The unit ventilates residential homes by extracting the inside humid air, and replacing it with fresh outside air, which has been heated with the heat energy of the extracted air. This reduces energy consumption.

The air volume can be controlled by:

- Selecting a fixed fan speed from 0-4
- Demand mode, in which a built in RH sensor continuously adjusts the fan speed depending on any immediate demand, determined by the humidity of the extracted air
- Week timer program – the fan speed will increase or decrease according to an hourly time schedule, or specific demand

When very humid inside air is extracted, the humidity will condensate inside the heat exchanger and be collected by the embedded drip tray. This water is drained from the unit through the enclosed hose and then disposed of in the nearest drainage. ducts connected to the home (supply and extract) are always on the left-hand side of the unit. The condensation drain is located at the rear of the unit.

Function

All units are equipped with easy-access filter slots. The control panel with LED light indicators is located in the front cover.

Cabinet

The RCV insulation is made of expanded polystyrene (EPS) with outer surface made of 0.8mm galvanised metal sheet metal. This has a high insulation level, and good air tightness, which permits location of the units in spaces with temperatures down to -12°C.

The leakage rate of the unit (internal and external) is <2% as specified in EN13141-7 leakage class A1.

Installation

After installation of the unit, ducts and condensate hose, the unit needs to be calibrated to the specific environment. Appropriate initial adjustments are performed with Dantherm PC Tool.

Maintenance

In general, the only regular maintenance required by the RCV residential ventilation units is to check/change the air filters once a year when the alarm is triggered (flashing LED and acoustic alarm).

The user changes the filter by opening the filter cover, changing the filters and resetting the filter timer on the built-in control panel.

Apart from changing the air filters and cleaning the outside of the unit, any other form of service will have to be carried out by qualified personnel.

Local Dantherm partners are always available with support to solve any problem that might arise with the unit.

Removing the front cover gives access to all types of service and repair.

RCV RANGE



Flexible unit

The factory-mounted duct seals on the side of the unit can easily be removed using a side cutter and then used to seal off other ducts not to be used.

Mirroring all duct connections

2 set-up in 1 unit, easy change on site

The air flow direction can be electronically swapped, providing ability to route the connected ducts, either to the right or to the left. This means that the supply air duct connections can be either to the right or to the left hand side of the unit.

Unlike all other residential ventilation units on the market, the RCV offers a stunning 48 different ways of connecting ducts to the unit.

24 available combinations for left setups (A) and 24 for right setups (B). Simply choose whichever one is more convenient in terms of installation!

With this flexible unit, you'll be able to find a fast and cost-efficient way to finalise installation work, even in the trickiest of installation areas.

On the RCV 320 it is possible to connect the supply duct to the bottom if the ducts are to run beneath the floor.



Duct connections

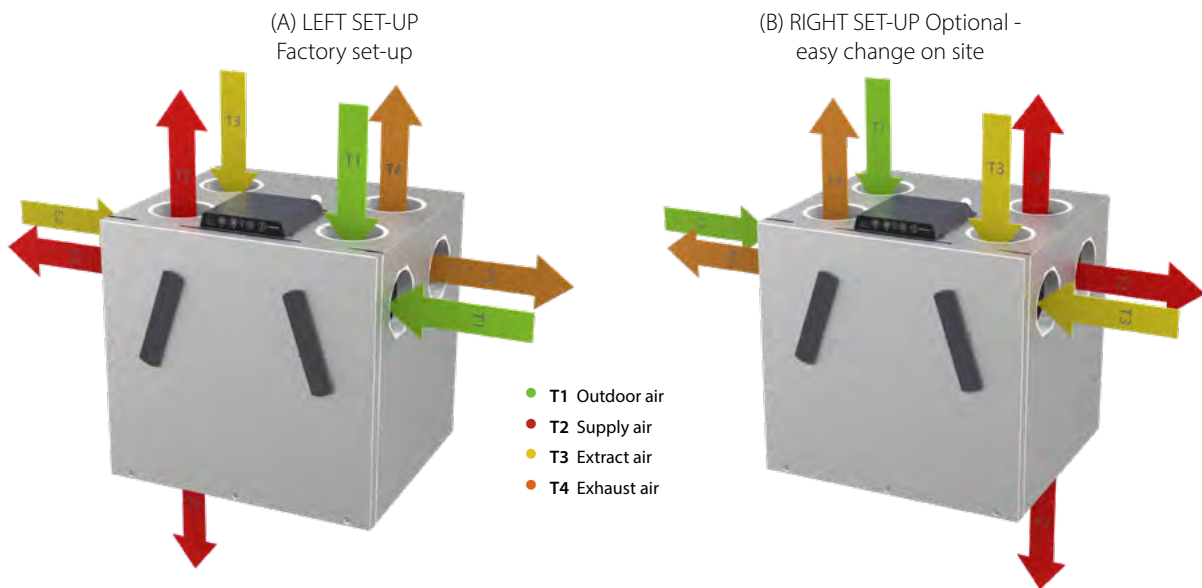

On the RCV 320 it is possible to connect the supply duct to the bottom if the ducts are to run beneath the floor

RCV 320P1



RCV 320P1

The 320P1 is a highly efficient and very compact residential ventilation unit for houses, villas, and apartments. Based on patent-pending technology and an ingenious design, it is delivered as a true plug and play solution with a built-in control panel and all necessary parts for on-site wall installation.

Heat recovery takes place in a highly efficient counter-flow heat exchanger, which is able to achieve optimum efficiency with the least possible loss of pressure in connection with the low air volumes used in housing.

All units come with an galvanised metal surface finish and will be packaged four units on a pallet at a time to ease handling at building sites.

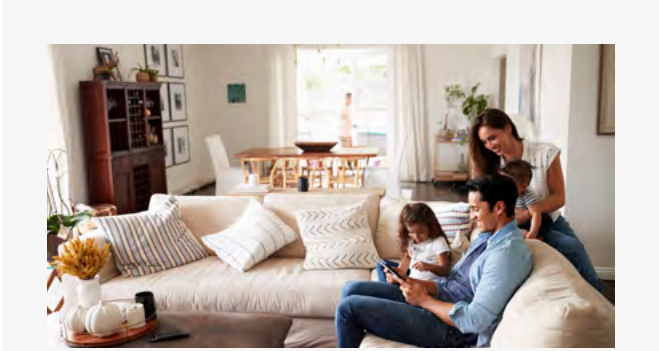

- Demand-controlled ventilation with integrated humidity sensor, reducing power consumption at times with low ventilation demands
- Summer mode in which the supply fan is stopped, thereby reducing power consumption. Open windows will supply cooler outside air, lowering the room temperature
- Automatic free-cooling features via inbuilt 100% by-pass, including the possibility of increasing the air flow automatically, lets in cool night air following hot days to help maintain a comfortable temperature throughout the day
- Fireplace mode, creating a temporary inside overpressure to enhance chimney functionality
- High-efficiency heat recovery
- EC fan motors with extremely low energy consumption (low SPI)
- Highly customisable units with the option to add a high variety of internal as well as external accessories
- Ducts can be connected through the top of the unit, either side or the bottom as preferred
- Compact design
- External pre-heater as accessory
- Free smartphone App available

Third party testing and certification

Code	Description
ErP	Compliant with EU regulations for Eco-design
Nordic Swan Ecolabel	Listed in the Nordic Swan database for products suitable for Ecolabelled buildings
PCDB listed SAP App. Q	Pending: Listed in the UK database for balanced whole-house mechanical ventilation with heat recovery
PHI	Passivhaus certified
EPB	Pending: Listed in the database for Energy Performance of Buildings in Belgium
EPD	Environmental product declaration for declared product variant is available in the epddanmark.dk database

RCV 320P1



Flexible unit

The factory-mounted duct seals on the side of the unit can easily be removed using a side cutter and then used to seal off other ducts not to be used.

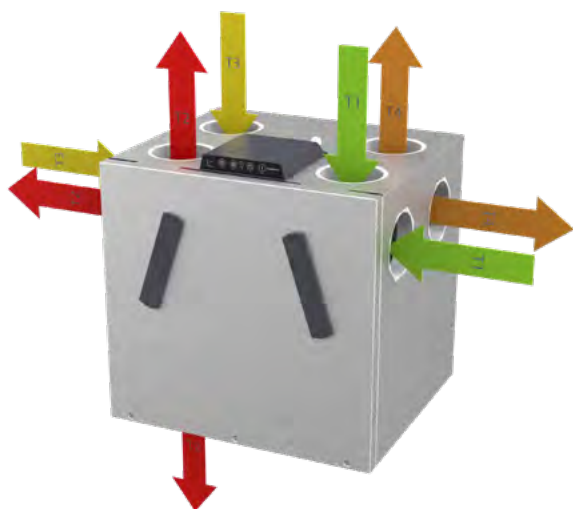

(A) LEFT SET-UP

Tired of having to redo ducting to fit ventilation units?

Unlike all other residential ventilation units on the market, the RCV offers a stunning 48 different ways of connecting ducts to the unit. 24 available combinations for left setups (A) and 24 for right setups (B). Simply choose whichever one is more convenient in terms of installation!

With this flexible unit, you'll be able to find a fast and cost-efficient way to finalise installation work, even in the trickiest of installation areas.

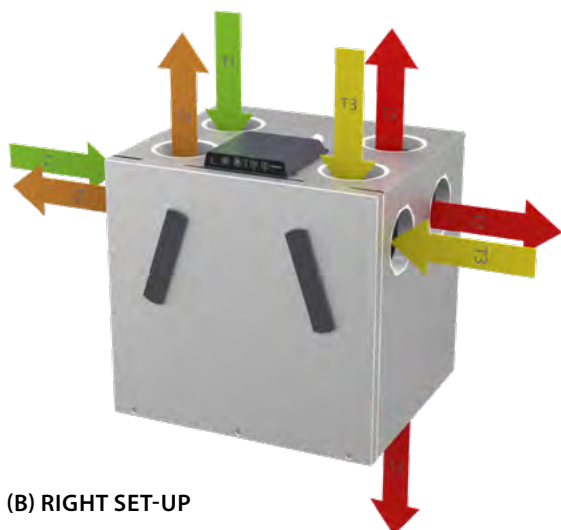

(B) RIGHT SET-UP

- T1 Outdoor air
- T2 Supply air
- T3 Extract air
- T4 Exhaust air

Specifications	Units		RCV 320P1
Maximum flow at 100Pa	V_{100Pa}	m ³ /h	320
Maximum rated flow at 100Pa	$V_{max. nom.}$	m ³ /h	200
Recommended operating range	V	m ³ /h	50-200
Operating range Passivhaus at 100Pa	V_{PHI}	m ³ /h	71-162
EN 13141-7 reference flow at 50Pa	V_{REF}	m ³ /h	140
Performance			
Thermal efficiency in accordance with PHI	η_{SUP}	%	94
Thermal efficiency in accordance with EN13141-7	η_{SUP}	%	95
Leakage (external and internal) in accordance with EN 13141-7			<2% (Class A1)
Filters in accordance with ISO16890	-	-	ISO Coarse 75% (optional on supply: ePM1>50%)
Filters in accordance with EN779:2012			G4 (optional on supply: F7)
Installation surrounding temperature	t_{SURR}	°C	-12 to +45
Outdoor temperature without preheater installed	t_{ODA}	°C	-12* to +45
Outdoor temperature with preheater installed	t_{ODA}	°C	-15 to +45
Maximum absolute humidity of extract air	x	g/kg	10
Cabinet			
Dimensions (without bracket)	w x h x d	mm	600 x 603 x 526**
Spigots/ducts connections	Ø	mm	8 pcs ø125 and 2 pcs oval (68 x 163) – female
Weight		kg	32
Thermal conductivity – polystyrene insulation	λ	W/mK	0.031
Heat transition figures – polystyrene insulation	U	W/m ² K	U<1
Fire classification of the polystyrene insulation	-	-	DIN 4102-1 class B2 EN 13501 class E
Drainage hose included	Ø/length	"/m	ø¾" – 1m
Cabinet colour	-	-	galvanised metal grey
Electrical			
Voltage	U	V	230
Maximum power consumption (without/with preheater)	P	W	170/1370
Frequency	f	Hz	50
Protection class	-	-	IP21

* The use of preheating coil is recommended at outdoor temperature -3°C to ensure balanced operation.

** +20mm fitting.

Capacity and SPI curves with G4/G4 filters

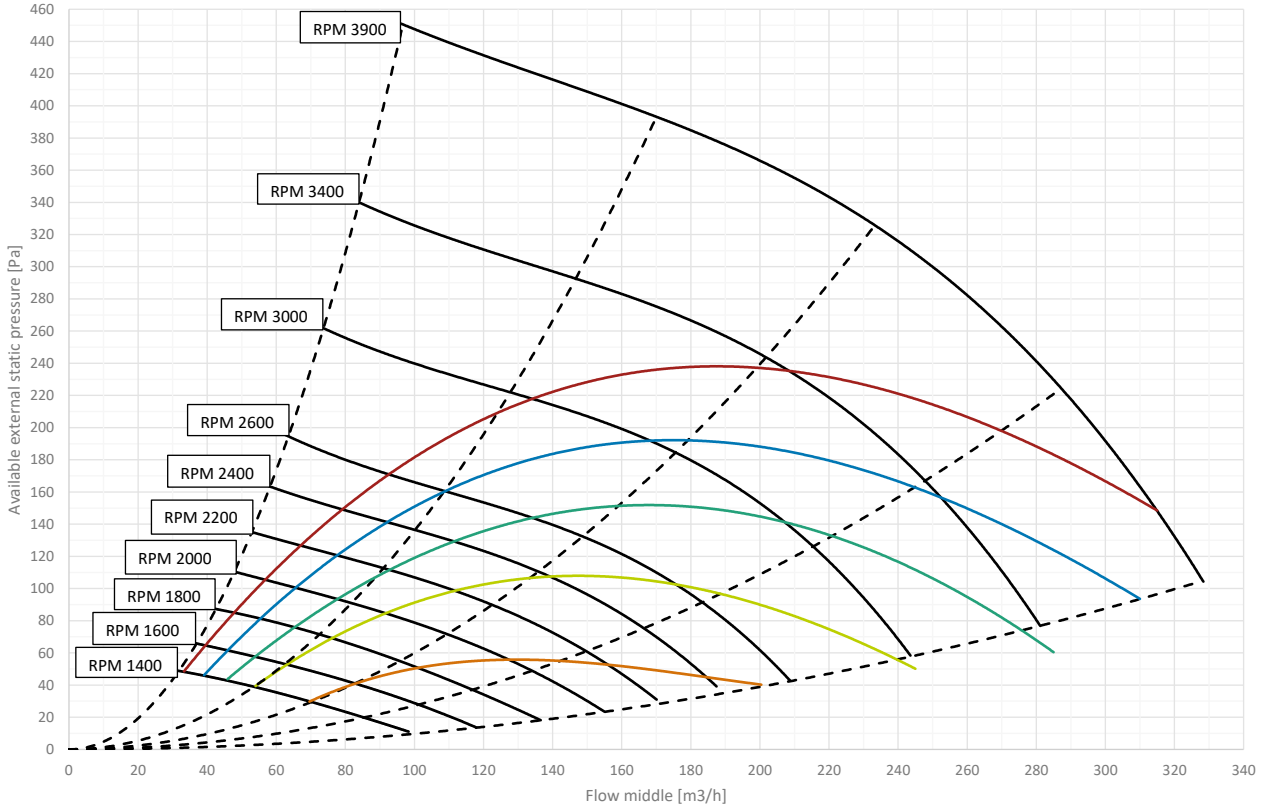

SFP/SPI/SEL*	0.45 W/m ³ /h	0.39 W/m ³ /h	0.33 W/m ³ /h	0.28 W/m ³ /h	0.22 W/m ³ /h
	1620 J/m ³	1400 J/m ³	1200 J/m ³	1000 J/m ³	800 J/m ³
	1.62 W/l/s	1.40 W/l/s	1.20 W/l/s	1.0 W/l/s	0.80 W/l/s

* SFP/SPI/SEL includes power consumption of both fans and the control.

Thermal efficiency curves

- Thermal efficiency according to EN 13141-7 (dry)
Operational conditions: outdoor air: 7°C, 85% RH; extract air: 20°C, 37% RH
 - Thermal efficiency according to EN 13141-7 (with condensation)
Operational conditions: outdoor air: 2°C, 85% RH; extract air: 20°C, 60% RH
 - Thermal efficiency acc. PassivHaus Institut
Operational conditions: outdoor air: 4°C, 94% RH; extract air: 21°C, 30% RH
- All values at balanced flow

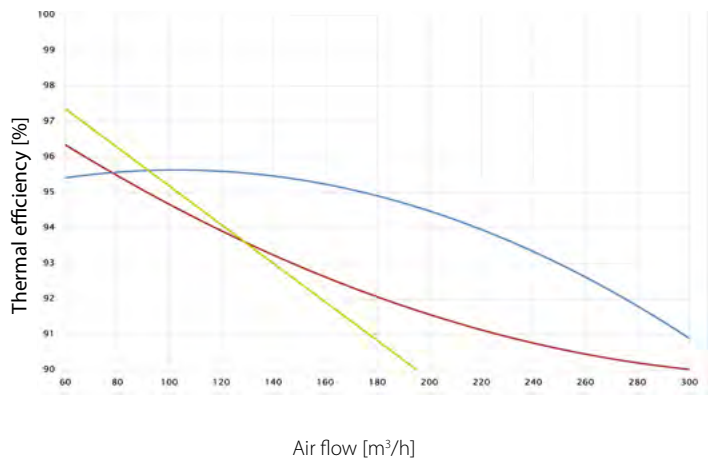

Sound power level (L_w) – ducts

RPM	Duct	[dB(A)]								
		63Hz	125Hz	250Hz	500Hz	1kHz	2kHz	4kHz	8kHz	Total
1200	supply/exhaust	23.6	33.1	32.8	34.0	30.0	20.8	13.3	18.5	39
	extract/outdoor	20.2	26.0	26.0	30.0	23.9	15.5	6.9	13.0	33
1400	supply/exhaust	26.2	36.1	37.0	37.2	34.4	24.6	19.0	18.6	42
	extract/outdoor	21.9	28.5	30.1	33.7	28.3	21.5	18.1	21.4	37
1600	supply/exhaust	27.8	36.7	41.0	40.2	37.6	28.8	22.0	19.1	45
	extract/outdoor	23.9	29.0	35.6	36.3	31.7	25.5	17.3	21.5	40
1800	supply/exhaust	30.2	38.1	46.1	43.1	40.6	32.1	24.9	13.3	49
	extract/outdoor	26.8	30.4	38.2	38.9	34.7	28.8	18.8	21.7	43
2000	supply/exhaust	32.0	39.8	49.4	45.8	43.5	35.2	28.5	13.0	52
	extract/outdoor	30.2	31.5	41.9	41.3	37.5	31.6	18.1	20.3	46
2200	supply/exhaust	34.2	40.9	51.0	48.1	46.0	38.1	31.8	12.7	54
	extract/outdoor	32.3	33.0	43.4	43.6	39.9	34.1	21.5	21.5	48
2400	supply/exhaust	35.4	42.3	54.4	50.1	47.6	40.6	34.7	18.7	57
	extract/outdoor	33.9	34.2	44.5	45.8	42.0	36.2	20.7	14.9	49
2600	supply/exhaust	38.6	43.9	55.8	52.4	49.7	43.1	37.5	19.7	58
	extract/outdoor	36.6	35.8	47.7	47.8	43.8	38.4	24.8	23.3	52
3000	supply/exhaust	40.1	45.6	59.0	62.5	53.1	47.0	41.9	26.9	65
	extract/outdoor	37.7	37.5	47.7	53.3	47.3	42.5	28.3	23.3	55
3400	supply/exhaust	43.8	51.4	62.4	68.8	57.0	50.2	45.7	31.9	70
	extract/outdoor	40.3	40.1	48.2	61.2	50.2	45.1	31.2	24.6	62

Sound pressure level (L_p) – cabinet**2m distance**

RPM	Without background noise weighted [dB(A)]								
	63Hz	125Hz	250Hz	500Hz	1kHz	2kHz	4kHz	8kHz	Total
1000	-	2.6	9.5	12.9	9.6	5.8	1.4	3.0	17
1200	-	4.0	11.1	15.8	16.3	12.6	9.4	4.1	21
1400	-	7.1	13.9	17.6	16.4	12.6	5.3	1.7	22
1600	-	8.5	18.0	20.8	17.7	13.2	6.0	-0.1	24
1800	-	10.0	21.9	23.6	20.2	16.3	9.4	4.9	27
2000	-	11.5	22.4	25.7	22.2	18.3	11.6	5.6	29
2200	-	13.3	26.5	28.2	24.6	20.7	13.3	5.6	32
2400	-	18.5	28.1	30.9	27.7	24.4	17.5	5.6	35
2600	11.0	20.1	29.9	34.6	29.5	25.6	18.9	5.6	37
3000	11.1	20.2	32.3	37.9	32.1	29.0	22.8	9.0	40

Dimensions

On the RCV 320P1, it is possible to connect the supply duct to the bottom if the ducts are to run beneath the floor.

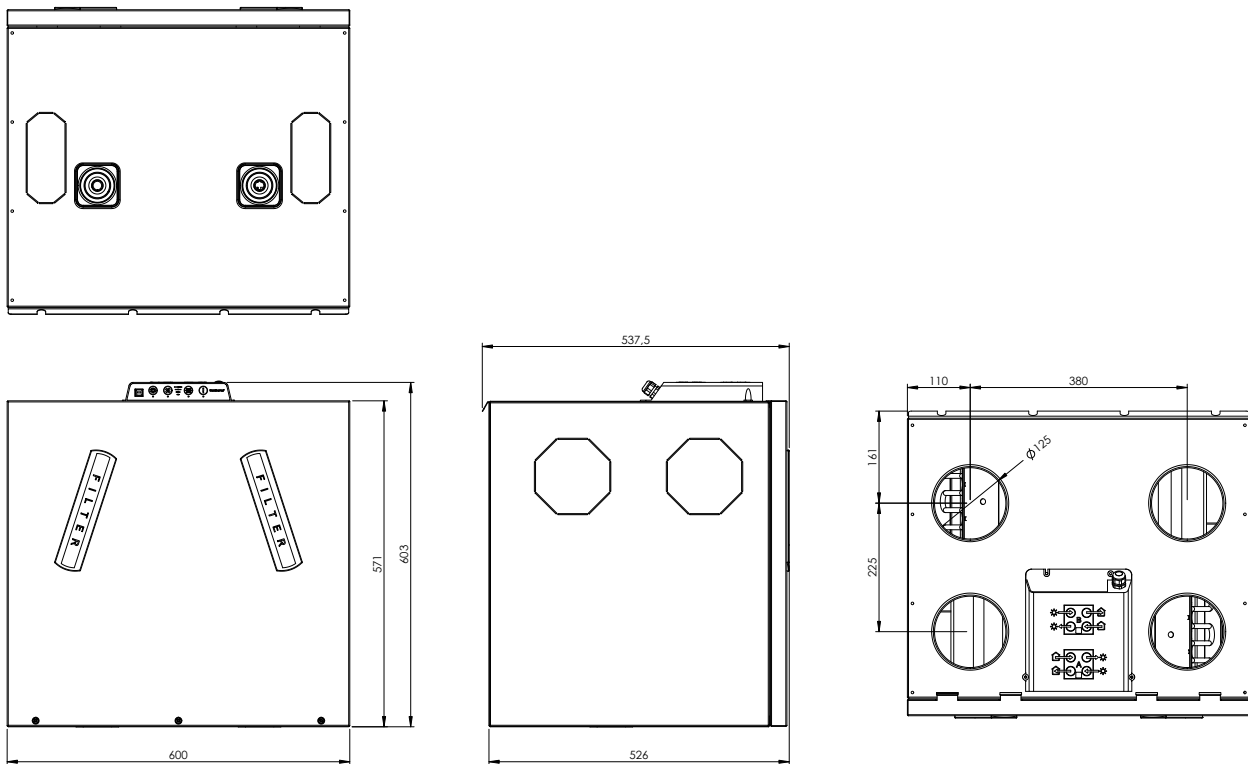

REVIT

Revit files are available for free on request.
Contact your local supplier or Dantherm for access.

RCV 320P2



RCV 320P2

The RCV 320P2 is a highly efficient and very compact residential ventilation unit for houses, villas, and apartments. Based on patent-pending technology and an ingenious design, it is delivered as a true plug and play solution with a built-in control panel and all necessary parts for on-site wall installation.

All units come with an galvanised metal surface finish and will be packaged four units on a pallet at a time to ease handling at building sites. In addition to speeding up your installation work, this reduces the amount of packaging materials for you to get rid of while also benefitting the environment.

- Demand-controlled ventilation with integrated humidity sensor, reducing power consumption at times with low ventilation demands
- Summer mode in which the supply fan is stopped and any open window will supply cooler outside air, lowering the room temperature
- Automatic free-cooling features via inbuilt 100% by-pass, including the possibility of increasing the air flow automatically, lets in cool night air following hot days to help maintain a comfortable temperature throughout the day
- Fireplace mode, creating a temporary inside overpressure to enhance chimney functionality
- High-efficiency heat recovery
- EC fan motors with extremely low energy consumption (low SPI)
- Highly customisable units with the option to add a high variety of internal as well as external accessories
- Ducts can be connected through the top of the unit, either side or the bottom as preferred
- Compact design
- Internal pre-heater as accessory

Third party testing and certification

Code	Description
ErP	Compliant with EU regulations for Eco-design
Nordic Swan Ecolabel	Listed in the Nordic Swan database for products suitable for Ecolabelled buildings
EPD	Environmental product declaration for declared product variant is available in the epddanmark.dk database

Specifications	Units		RCV 320P2
Maximum flow at 100Pa	V_{100Pa}	m^3/h	320
Maximum rated flow at 100Pa	$V_{max.nom.}$	m^3/h	200
Recommended operating range	V	m^3/h	50-200
EN 13141-7 reference flow at 50Pa	V_{REF}	m^3/h	140
Performance			
Thermal efficiency in accordance with EN13141-7	η_{SUP}	%	90
Leakage (external and internal) in accordance with EN 13141-7			<2% (Class A1)
Filters in accordance with ISO16890	-	-	ISO Coarse 75% (optional on supply: ePM1>50%)
Filters in accordance with EN779:2012			G4 (optional on supply: F7)
Installation surrounding temperature	t_{SURR}	$^{\circ}C$	-12 to +45
Outdoor temperature without preheater installed	t_{ODA}	$^{\circ}C$	-12* to +40
Outdoor temperature with preheater installed	t_{ODA}	$^{\circ}C$	-15 to +40
Maximum absolute humidity of extract air	x	g/kg	10
Cabinet			
Dimensions (without bracket)	w x h x d	mm	600 x 603 x 526**
Spigots/ducts connections	\emptyset	mm	8 pcs \emptyset 125 and 2 pcs oval (68 x 163) – female
Weight		kg	32
Thermal conductivity – polystyrene insulation	λ	W/mK	0.031
Heat transition figures – polystyrene insulation	U	W/m ² K	U<1
Fire classification of the polystyrene insulation	-	-	DIN 4102-1 class B2 EN 13501 class E
Drainage hose included	\emptyset /length	"/m	\emptyset 3/4" – 1m
Cabinet colour	-	-	galvanised metal grey
Electrical			
Voltage	U	V	230
Maximum power consumption (without/with preheater)	P	W	170/1070
Frequency	f	Hz	50
Protection class	-	-	IP21

* The use of preheating coil is recommended at outdoor temperature -3°C to ensure balanced operation.

** +20mm fitting.

Capacity and SPI curves with G4/G4 filters

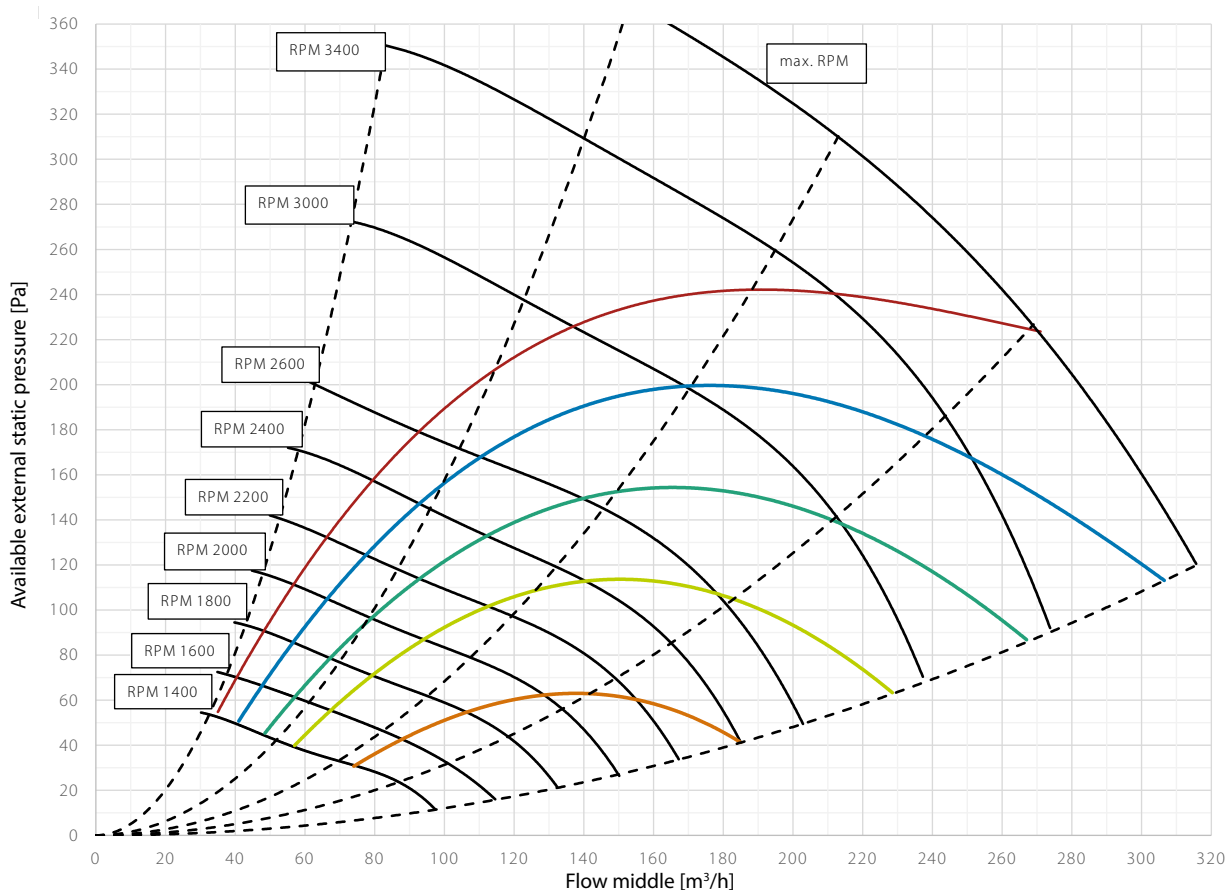

SFP/SPI/SEL*	0.45 W/m ³ /h	0.39 W/m ³ /h	0.33 W/m ³ /h	0.28 W/m ³ /h	0.22 W/m ³ /h
	1620 J/m ³	1400 J/m ³	1200 J/m ³	1000 J/m ³	800 J/m ³
	1.62 W/l/s	1.40 W/l/s	1.20 W/l/s	1.0 W/l/s	0.80 W/l/s

* SFP/SPI/SEL includes power consumption of both fans and the control.

Thermal efficiency curves

Legend

- Thermal efficiency according to EN 13141-7 (dry)
Operational conditions: outdoor air: 7°C, 85% RH; extract air: 20°C, 37% RH

All values at balanced flow

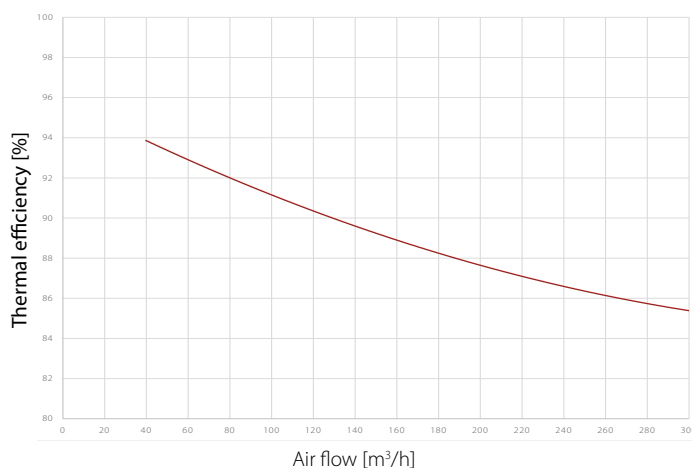

Sound power level (L_w) – ducts

RPM	Duct	[dB(A)]								
		63Hz	125Hz	250Hz	500Hz	1kHz	2kHz	4kHz	8kHz	Total
1200	supply/exhaust	23.6	33.1	32.8	34.0	30.0	20.8	13.3	18.5	39
	extract/outdoor	20.2	26.0	26.0	30.0	23.9	15.5	6.9	13.0	33
1400	supply/exhaust	26.2	36.1	37.0	37.2	34.4	24.6	19.0	18.6	42
	extract/outdoor	21.9	28.5	30.1	33.7	28.3	21.5	18.1	21.4	37
1600	supply/exhaust	27.8	36.7	41.0	40.2	37.6	28.8	22.0	19.1	45
	extract/outdoor	23.9	29.0	35.6	36.3	31.7	25.5	17.3	21.5	40
1800	supply/exhaust	30.2	38.1	46.1	43.1	40.6	32.1	24.9	13.3	49
	extract/outdoor	26.8	30.4	38.2	38.9	34.7	28.8	18.8	21.7	43
2000	supply/exhaust	32.0	39.8	49.4	45.8	43.5	35.2	28.5	13.0	52
	extract/outdoor	30.2	31.5	41.9	41.3	37.5	31.6	18.1	20.3	46
2200	supply/exhaust	34.2	40.9	51.0	48.1	46.0	38.1	31.8	12.7	54
	extract/outdoor	32.3	33.0	43.4	43.6	39.9	34.1	21.5	21.5	48
2500	supply/exhaust	35.4	42.3	54.4	50.1	47.6	40.6	34.7	18.7	57
	extract/outdoor	33.9	34.2	44.5	45.8	42.0	36.2	20.7	14.9	49
2700	supply/exhaust	38.6	43.9	55.8	52.4	49.7	43.1	37.5	19.7	58
	extract/outdoor	36.6	35.8	47.7	47.8	43.8	38.4	24.8	23.3	52
2900	supply/exhaust	40.1	45.6	59.0	62.5	53.1	47.0	41.9	26.9	65
	extract/outdoor	37.7	37.5	47.7	53.3	47.3	42.5	28.3	23.3	55

Sound pressure level (Lp) – cabinet**1m distance**

RPM	[dB(A)]								
	63Hz	125Hz	250Hz	500Hz	1kHz	2kHz	4kHz	8kHz	Total
1000	-	2.8	11.4	14.7	11.7	10.6	2.7	3.0	19
1200	-	4.1	16.7	15.9	16.4	13.0	9.7	4.9	22
1400	-	7.3	18.5	19.6	17.7	13.2	10.0	4.9	24
1600	-	9.5	22.5	21.0	19.3	13.3	10.3	4.9	26
1800	-	10.3	24.6	24.5	22.2	18.1	11.1	5.6	29
2000	-	11.7	26.7	26.8	24.3	19.3	11.8	6.3	31
2200	-	13.5	30.6	29.5	26.7	21.9	14.7	6.3	34
2400	-	18.6	30.9	32.2	30.3	25.3	18.3	6.3	36
2600	11.0	20.2	34.0	35.0	31.3	26.5	20.5	7.3	39
3000	11.1	20.3	35.3	38.9	34.9	30.3	26.7	10.6	42

2m distance

RPM	[dB(A)]								
	63Hz	125Hz	250Hz	500Hz	1kHz	2kHz	4kHz	8kHz	Total
1000	-	2.6	9.5	12.9	9.6	5.8	1.4	3.0	17
1200	-	4.0	11.1	15.8	16.3	12.6	9.4	4.1	21
1400	-	7.1	13.9	17.6	16.4	12.6	5.3	1.7	22
1600	-	8.5	18.0	20.8	17.7	13.2	6.0	-0.1	24
1800	-	10.0	21.9	23.6	20.2	16.3	9.4	4.9	27
2000	-	11.5	22.4	25.7	22.2	18.3	11.6	5.6	29
2200	-	13.3	26.5	28.2	24.6	20.7	13.3	5.6	32
2400	-	18.5	28.1	30.9	27.7	24.4	17.5	5.6	35
2600	11.0	20.1	29.9	34.6	29.5	25.6	18.9	5.6	37
3000	11.1	20.2	32.3	37.9	32.1	29.0	22.8	9.0	40

Dimensions

On the RCV 320, it is possible to connect the supply duct to the bottom if the ducts are to run beneath the floor.

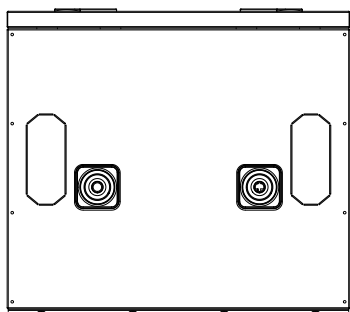

REVIT

Revit files are available for free on request. Contact your local supplier or Dantherm for access.

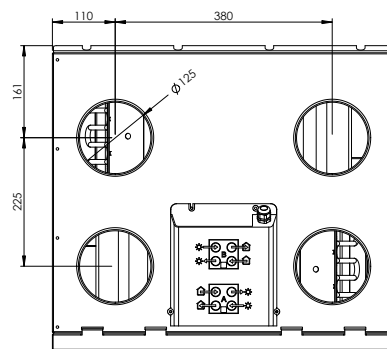
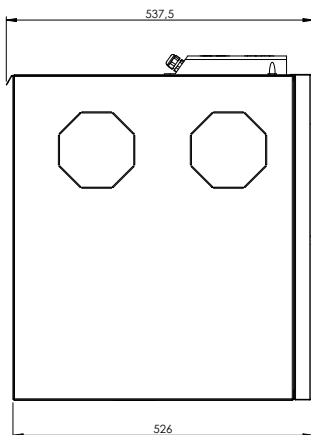
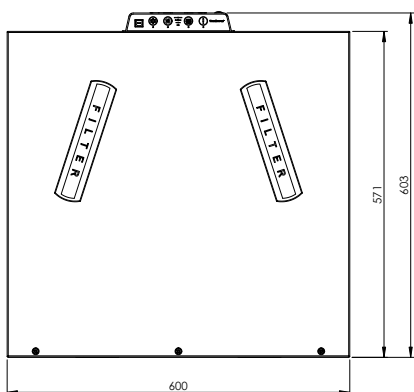

Duct connections

(A) LEFT SET-UP
Factory set-up

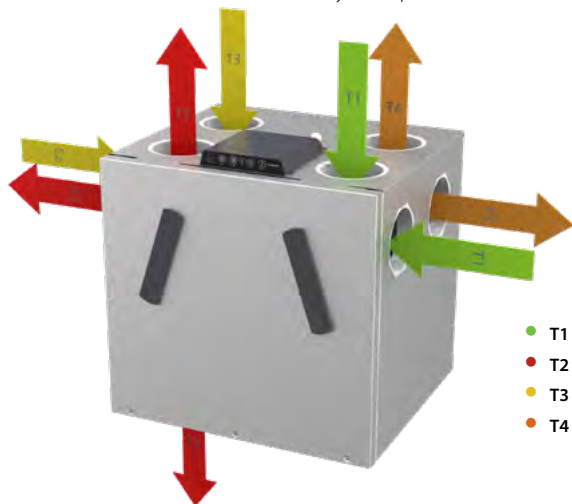

(B) RIGHT SET-UP Optional -
easy change on site

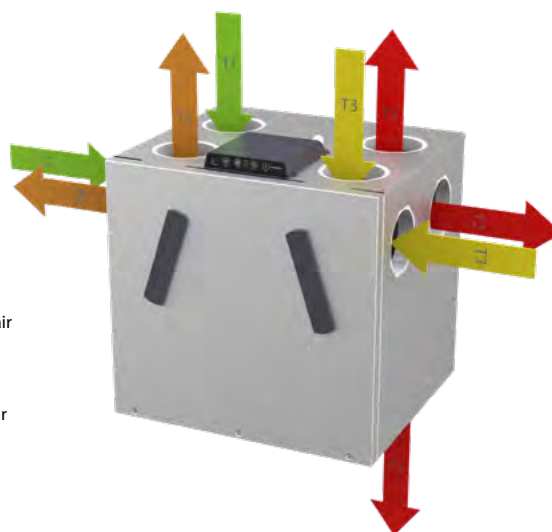

- T1 Outdoor air
- T2 Supply air
- T3 Extract air
- T4 Exhaust air

HCH RANGE



For a quick selection of the product range you can use the selection chart below. The selection chart shows the air volumes at 100Pa pressure loss.

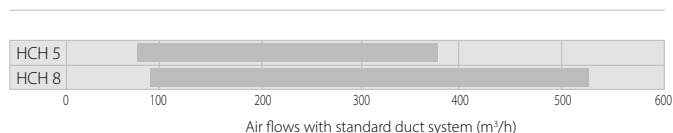

Overview

The HCH residential ventilation units are primarily designed for 1 and 2 family houses. The units are supplied as packaged ventilation units complete with a control panel. The residential ventilation units are fitted with highly efficient counter-flow heat exchangers which are optimised to a very high efficiency level thus achieving a very low specific fan power (SFP value) for the entire unit.

For a quick selection you can use the selection chart below. The selection chart shows the air volumes when operating with a normal duct system with normal pressure drop.

All HCH models are fully operational in surrounding temperatures down to -12°C.

The HCH residential ventilation units are horizontal models designed to be fitted in the loft or on the floor of a plant room. They fulfil the ventilation requirements of houses up to approximately 475m², depending on national requirements and the actual pressure loss in the installation.

All HCH models have duct connections at the ends and service access at the front. Electrical connection is at the end of the unit facing the fresh air – right-hand – side. The ducts connected to the home (supply and extract) are always on the left-hand side of the unit. The condensation drain is located at the rear of the unit.



Filters

All models use 50mm G4 compact filters as standard for both supply air and extract air. This will cater for the majority of air cleaning needs. The advantage of compact filters is that they have a considerably larger filter surface area than fibrous filters and small bag filters. The filter thus works for longer and under normal conditions, it will not need changing more than twice a year, equivalent to the filter timer setting.

If necessary, F7 filters (pollen filters) are available as accessories, which ensure that allergens do not enter the home through the ventilation system.

**PANEL FILTERS****CHANGING THE HCH FILTER****Installation**

Measurement and adjustment of air volumes is done via pressure nozzles and PC-tool. A performance graph is adhered to the polystyrene front showing the pressure and air volumes the installer must use to determine the correct fan speeds. The label also has a space for the installer to write in the air volumes, the back pressure and fan speeds to which the system has been adjusted.

Operation

The two horizontal models HCH 5 and HCH 8 are operated via the control panel. It is recommended to connect an App or HCP11 so that the status of the unit can be seen/heard and adjusted.

Safety operation – connection to a smoke or fire alarm system

It is possible to connect a standard smoke/fire alarm system to the HCH residential ventilation unit. When activated, the alarm system will give a fire alarm signal and stop both fans to avoid more smoke/fire to enter from outside. Once the smoke/fire danger is no longer present, the unit must be restarted manually by reset button on foil panel.

When desired (due to higher risk of smoke/fire or higher safety requirements), it is also possible to build duct dampers into the duct work and have the ventilation unit open/close these whenever the unit is running/stopped. The damper motors (one for supply and one for extract air) can be powered and controlled by the accessory controller FPC (Fire Protections Controller).

Service and maintenance

In general, the only regular maintenance required by HCH products is to check/change the air filters twice a year, when the alarm LED blinks yellow and the acoustic alarm bleeps once an hour. On the HCH models, the front panel is removed, after which the two filters can be changed and the filter timer reset.

Apart from changing the air filters and cleaning the outside of the unit, any other form of service will have to be carried out by qualified personnel. Local Dantherm technicians and Dantherm partners are always available to solve any problem with the unit that might arise.

**HCH 5**

The HCH 5 residential ventilation unit is primarily designed for 1-2 family houses. The unit is supplied as packaged ventilation units complete with built-in demand-control and a control panel. The residential ventilation units are fitted with highly efficient counter-flow heat exchangers which are optimised to a very high efficiency level thus achieving a very low specific fan power (SFP value) for the entire unit.



- Demand-controlled ventilation with integrated humidity sensor, reducing power consumption at times with low ventilation demands
- High-efficiency heat recovery
- EC motors with extremely low energy consumption (low SFP)
- Easy-to-install solution with pressure pipes for air volume measurement and adjustment via PC-Tool
- HCH models are suitable for installation on uninsulated attics
- Summer mode in which the supply fan is stopped and any open window will supply cooler outside air, lowering the room temperature
- Automatic free-cooling features via inbuilt 100% by-pass, including the possibility of increasing the air flow automatically, lets in cool night air following hot days to help maintain a comfortable temperature throughout the day
- Fireplace mode, creating a temporary inside overpressure to enhance chimney functionality
- Highly customisable units with the option to add a high variety of internal as well as external accessories
- Internal pre-heater as accessory

Third party testing and certifications

Code	Description
PHI	Passivhaus certified
PCDB listed SAP App. Q	Listed in the UK database for balanced whole-house mechanical ventilation with heat recovery
EPB	Listed in the database for Energy Performance of Buildings in Belgium
ErP	Compliant with EU regulations for Eco-design
Nordic Swan Ecolabel	Listed in the Nordic Swan database for products suitable for Ecolabelled buildings

Specifications	Units		HCH 5
Maximum achievable flow at 100Pa	V100Pa	m ³ /h	350
Maximum declared flow at 100Pa	V _{max.rated}	m ³ /h	300
Recommended operating range	V	m ³ /h	80-300
EN 13141-7 reference flow at 50Pa	V _{ref}	m ³ /h	210
Performance			
Thermal efficiency	η_{EN}	%	Up to 94 **
Leakage (external and internal) according to EN 13141-7	class		<2% (Class A1)
Filters in accordance with EN779			G4 (optional on supply: F7)
Filters in accordance with ISO 16890			ISO Coarse 75% (optional on supply: ePM1>50%)
By-pass			Yes
Installation surrounding temperature range	t _{surr}	°C	-12 to +50
Operational temperature range without preheating	t _{ODA}	°C	-13 *** to +50
Operational temperature range with preheating	t _{ODA}	°C	-20 to +50
Cabinet			
Dimensions	w x h x d	mm	1180 x 600 x 580
Duct connection	∅	mm	160
Weight		kg	52
Weight including packaging		kg	66
Dimensions including packaging and pallet	w x h x d	mm	1210 x 610 x 750
Outer cabinet material			galvanised metal
Colour	RAL		galvanised metal grey
Cabinet insulation, polystyrene		mm	40
Insulation factor – cabinet		W/m ² x °K	0.78
Fire classification – polystyrene cabinet			DIN 4102 class B1
Fire classification – whole unit			EN 13501 class E
Electrical			
Voltage	U	V	1 x 230
Maximum power consumption (without/with preheater)	P	W	154/1554
Frequency	f	Hz	50
Protection class			IP20

* Requires an Energy Efficiency Class A+ kit (including CO₂ sensor and HAC accessory control). Described under Accessories.

** Condensing operation.

We recommend preheating at temperatures under -3°C to ensure a balanced operation.

Capacity and SPI curves with G4/G4 filters

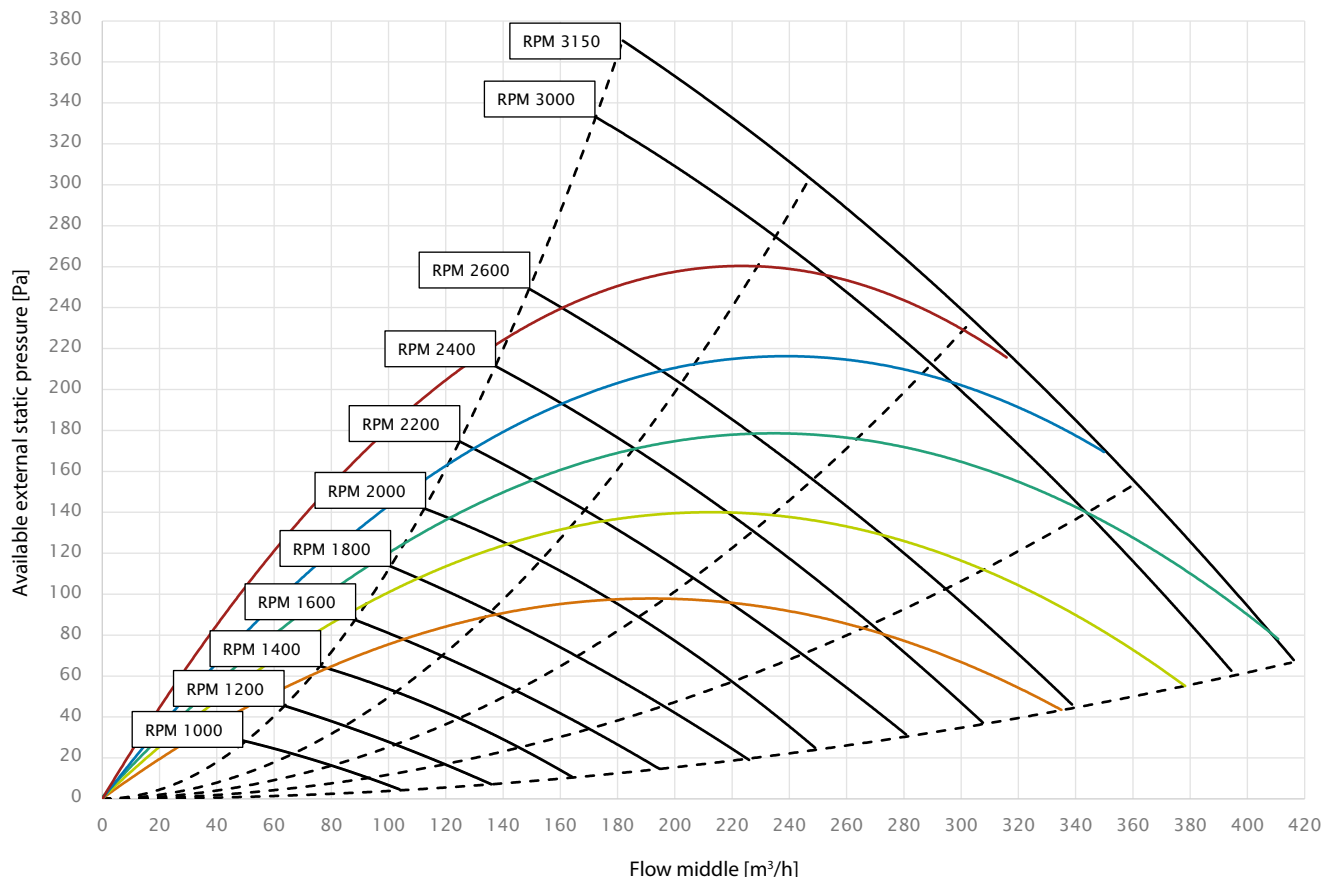

SFP/SPI/SEL*	0.45 W/m ³ /h	0.39 W/m ³ /h	0.33 W/m ³ /h	0.28 W/m ³ /h	0.22 W/m ³ /h
	1620 J/m ³	1400 J/m ³	1200 J/m ³	1000 J/m ³	800 J/m ³
	1.62 W/l/s	1.40 W/l/s	1.20 W/l/s	1.0 W/l/s	0.80 W/l/s

* SFP/SPI/SEL includes power consumption of both fans and the control.

Thermal efficiency curves

Legend

- Thermal efficiency according to EN 13141-7 (dry)
Operational conditions: outdoor air: 7°C, 80% RH; extract air: 20°C, 38% RH
- Thermal efficiency (with condensation)
Operational conditions: outdoor air: -10°C, 50% RH; extract air: 25°C, 55% RH
- Thermal efficiency according Passivhaus Institut
Operational conditions: outdoor air: 4°C, 90% RH; extract air: 21°C, 32% RH

All values at balanced flow

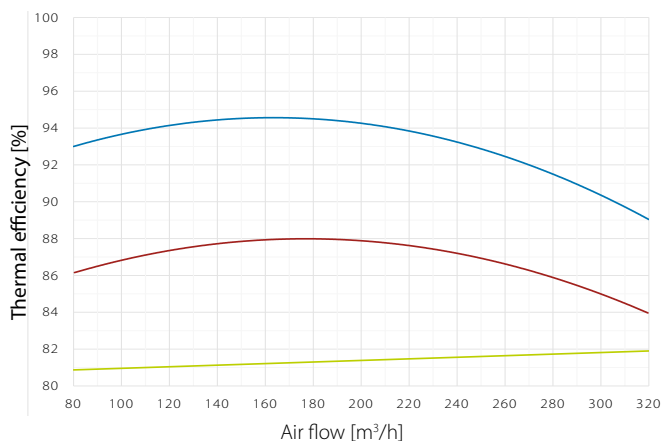

Sound data with G4/G4 filters

Flow m ³ /h	Pres. Pa	Measure point	Frequency band sound power L _w (A) dB(A)								Total sound power L _w (A) dB(A)	Sound pres. L _p (A) Standard room*
			63Hz	125Hz	250Hz	500Hz	1000Hz	2000Hz	4000Hz	8000Hz		
162	70	Supply air	23	34	40	36	29	25	17	18	42	
		Extract air	23	33	39	37	29	24	18	18	42	
		Cabinet	22	31	39	41	31	29	23	21		40
	100	Supply air	25	35	43	38	31	28	18	18	45	
		Extract air	25	36	42	39	40	25	17	18	45	
		Cabinet	23	34	41	42	33	31	24	21		41
216	70	Supply air	26	36	44	39	33	30	19	18	46	
		Extract air	28	36	43	41	34	29	18	18	46	
		Cabinet	28	35	45	44	37	35	27	21		45
	100	Supply air	26	37	44	40	34	31	19	18	47	
		Extract air	27	37	45	42	35	30	19	18	48	
		Exhaust air	34	43	52	52	47	51	38	21	57	
		Cabinet	26	34	46	45	38	36	28	21		46
250	100	Supply air	28	39	46	42	37	33	21	18	49	
		Extract air	30	39	48	45	38	33	20	18	50	
		Cabinet	28	36	50	48	41	39	32	22		49

* Standard room = room with 10m² floor, 2.4m ceiling height, mean absorption 0.2.

HCH 5



Dimensions

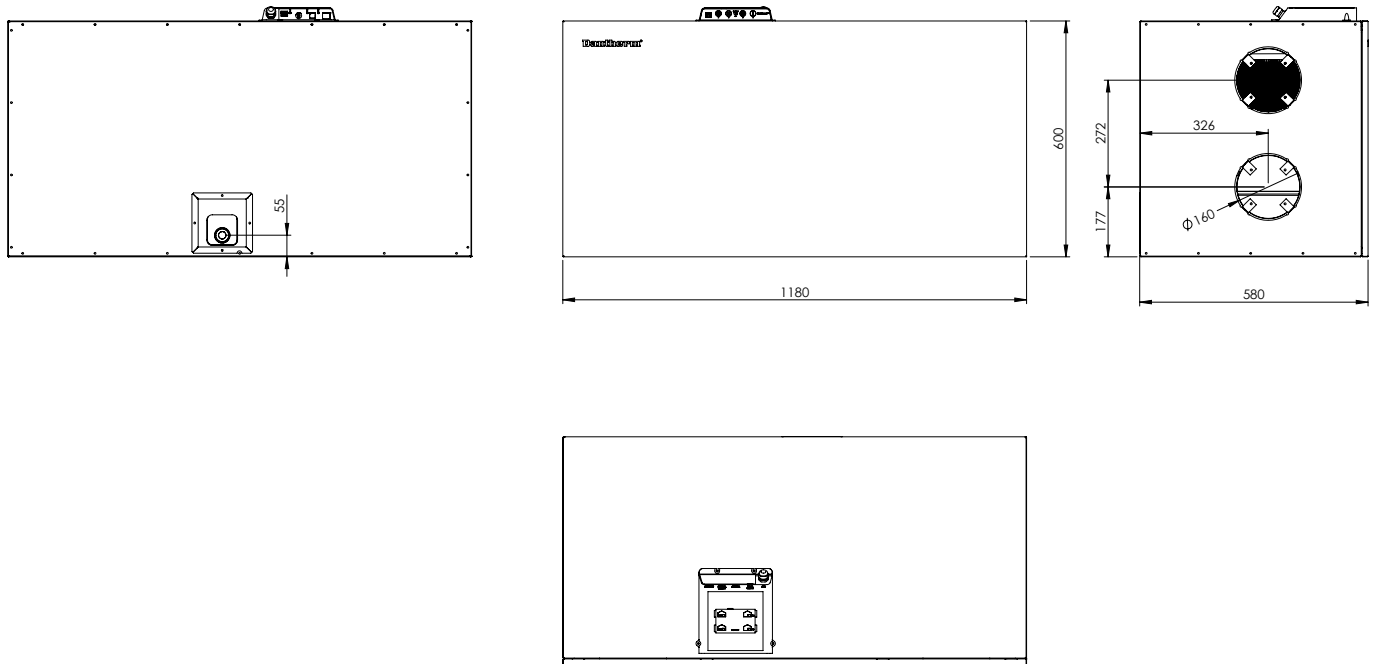

Duct connections



HCH 8



HCH 8

The HCH 8 residential ventilation unit is primarily designed for 1-2 family houses. The units are supplied as packaged ventilation units complete with built-in demand-control and a control panel. The residential ventilation units are fitted with highly efficient counter-flow heat exchangers which are optimised to a very high efficiency level thus achieving a very low specific fan power (SFP value) for the entire unit.

- Demand-controlled ventilation with integrated humidity sensor, reducing power consumption at times with low ventilation demands
- High-efficiency heat recovery
- EC motors with extremely low energy consumption (low SFP)
- Easy-to-install solution with pressure pipes for air volume measurement and adjustment via PC-Tool
- HCH models are suitable for installation on uninsulated attics
- Summer mode in which the supply fan is stopped and any open window will supply cooler outside air, lowering the room temperature
- Automatic free-cooling features via inbuilt 100% by-pass, including the possibility of increasing the air flow automatically, lets in cool night air following hot days to help maintain a comfortable temperature throughout the day
- Fireplace mode, creating a temporary inside overpressure to enhance chimney functionality
- Highly customisable units with the option to add a high variety of internal as well as external accessories

Third party testing and certifications

Code	Description
PHI	Passivhaus certified
PCDB listed SAP App. Q	Listed in the UK database for balanced whole-house mechanical ventilation with heat recovery
EPB	Listed in the database for Energy Performance of Buildings in Belgium
ErP	Compliant with EU regulations for Eco-design
Nordic Swan Ecolabel	Listed in the Nordic Swan database for products suitable for Ecolabelled buildings

Specifications	Units		HCH 8
Maximum achievable flow at 100Pa	V100Pa	m ³ /h	500
Maximum declared flow at 100Pa	V _{max.rated}	m ³ /h	500
Recommended operating range	V	m ³ /h	80-500
EN 13141-7 reference flow at 50Pa	V _{ref}	m ³ /h	350
Performance			
Thermal efficiency	η_{EN}	%	Up to 92%**
By-pass			Yes
Filters in accordance with EN779			G4 (optional on supply: F7)
Filters in accordance with ISO 16890			ISO Coarse 75% (optional on supply: ePM1>50%)
Surrounding temperature where the unit is installed		°C	-12 to +50
Operational temperature range without preheating		°C	-13*** to +50
Operational temperature range with preheating		°C	-20 to +50
Leakage (external and internal) according to EN 13141-7	class		<2% (Class A1)
Cabinet			
Dimensions	w x d x h	mm	1180 x 780 x 600
Duct connection	Ø	mm	250
Weight, unit		kg	70
Weight including packaging		kg	84
Dimensions including packaging and pallet (w x d x h)		mm	1200 x 800 x 775
Outer cabinet material			galvanised metal
Colour	RAL		galvanised metal grey
Cabinet insulation – polystyrene		mm	40
Insulation factor – cabinet		W/m ² x °K	0.78
Fire classification – polystyrene cabinet			DIN 4102 class B1
Fire classification – whole unit			EN 13501 class E
Protection class			IP20
Electrical			
Voltage	U	V	1 x 230
Frequency	f	Hz	50
Max. current consumption, without pre- and after-heat		A	1.1
Max. power consumption, without pre- and after-heat	P	W	246

* Requires an Energy Efficiency Class A+ kit (including CO₂ sensor and HAC accessory control). Described under Accessories.

** Condensing operation.

We recommend preheating at temperatures under -3°C to ensure a balanced operation.

Capacity and SPI curves with G4/G4 filters

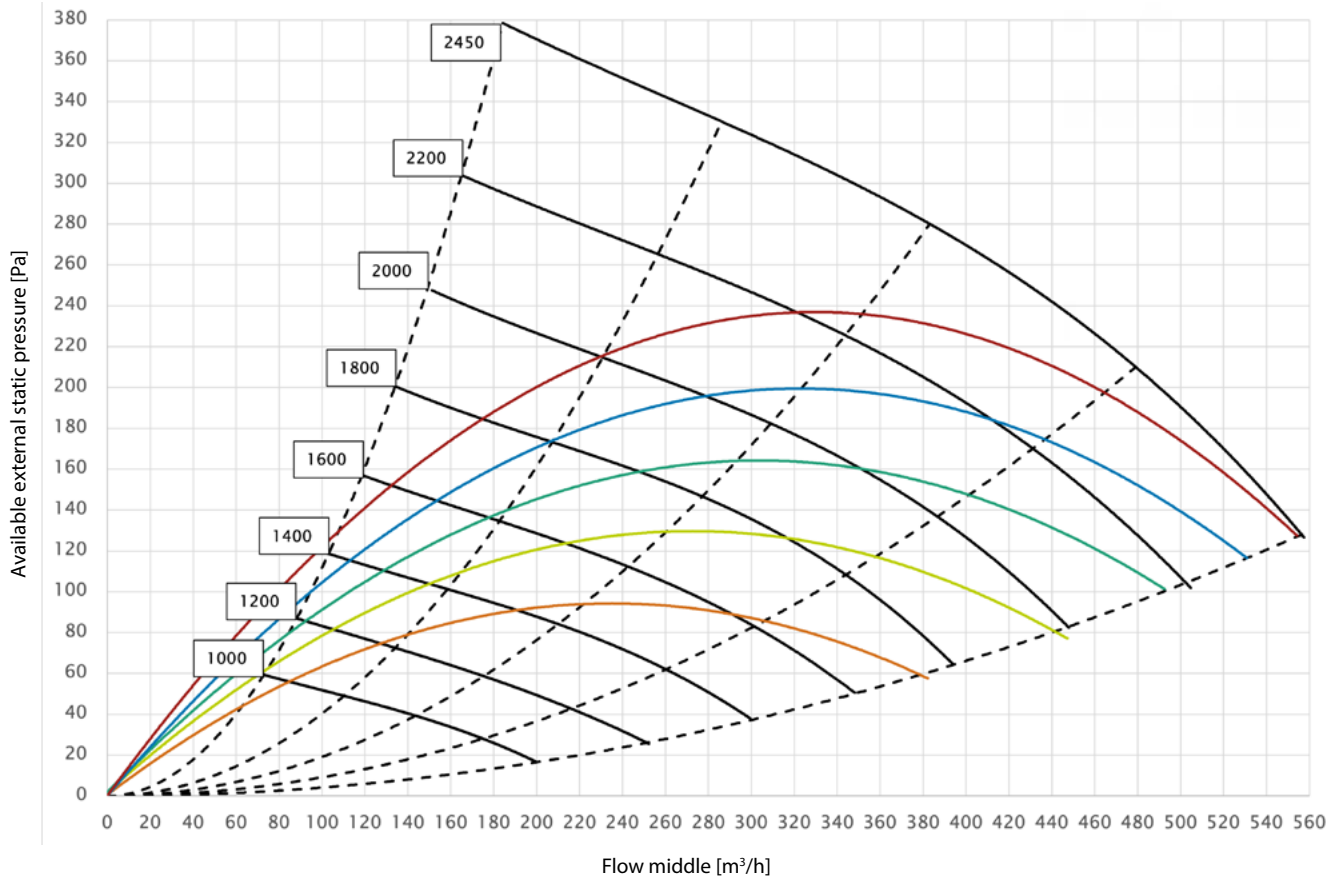

	—	—	—	—	—
SFP/SPI/SEL*	0.45 W/m ³ /h	0.39 W/m ³ /h	0.33 W/m ³ /h	0.28 W/m ³ /h	0.22 W/m ³ /h
	1620 J/m ³	1400 J/m ³	1200 J/m ³	1000 J/m ³	800 J/m ³
	1.62 W/l/s	1.40 W/l/s	1.20 W/l/s	1.0 W/l/s	0.80 W/l/s

* SFP/SPI/SEL includes power consumption of both fans and the control.

Thermal efficiency curves

Legend

- Thermal efficiency according to EN 13141-7 (dry)
Operational conditions: outdoor air: 7°C, 80% RH; extract air: 20°C, 38% RH
 - Thermal efficiency (with condensation)
Operational conditions: outdoor air: -10°C, 50% RH; extract air: 25°C, 55% RH
 - Thermal efficiency according Passivhaus Institut
Operational conditions: outdoor air: 4°C, 90% RH; extract air: 21°C, 32% RH
- All values at balanced flow

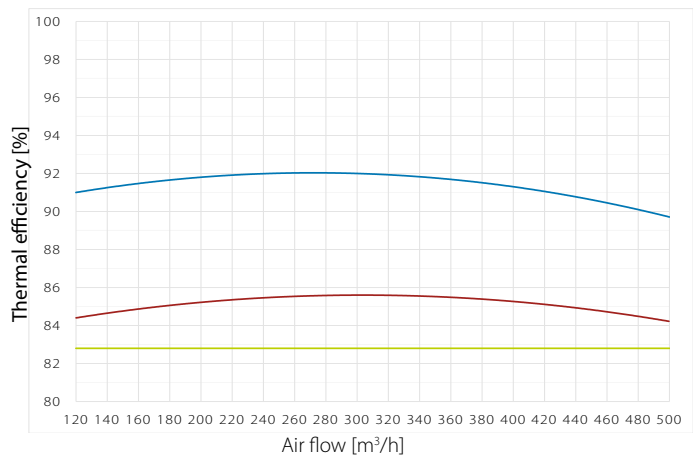

HCH 8



Sound data with G4/G4 filters

Flow m ³ /h	Pres. Pa	Measure point	Frequency band sound power L _w (A) dB(A)								Total sound power L _w (A) dB(A)	Sound pres. L _p (A) Standard room*
			63Hz	125Hz	250Hz	500Hz	1000Hz	2000Hz	4000Hz	8000Hz		
350	100	Supply air	44	51	56	50	43	38	23	7	63	
		Extract air	41	47	48	46	41	36	23	2	59	
		Cabinet	26	37	52	43	40	37	23	17		52
450	100	Supply air	39	48	62	55	52	50	37	22	67	
		Extract air	39	47	61	55	53	48	37	20	66	
		Cabinet	38	46	60	52	50	47	36	22		61

* Standard room = room with 10m² floor, 2.4m ceiling height, mean absorption 0.2.

Dimensions

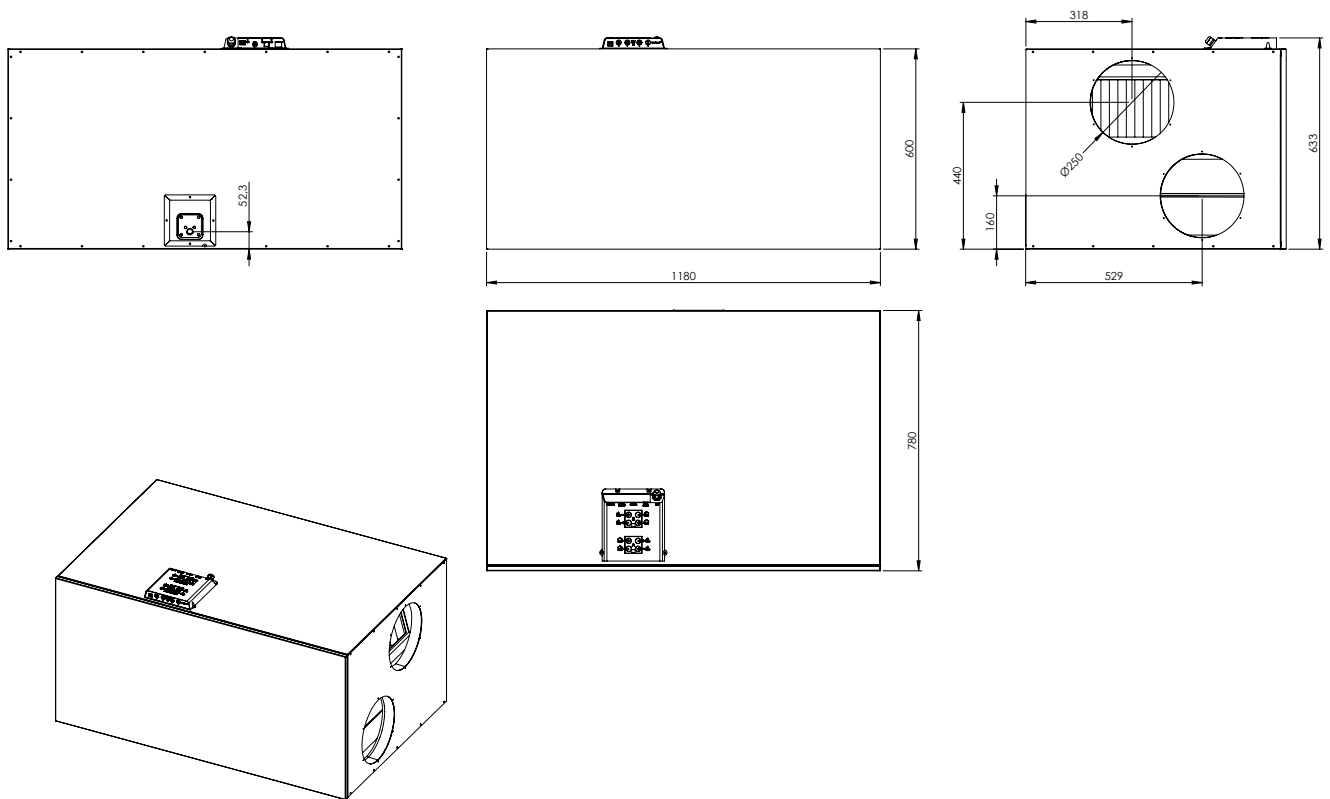

VENTILATION ACCESSORIES



The HCV 400-460 Silencer Box reduces fan and air flow noise before it is carried into the duct system. It is made of galvanised metal painted in colour RAL 9016. The ends of the sound attenuators are fitted with coupling connections and can be mounted directly on top of the HCV 400 or HCV 460 residential ventilation units.

Illustration	Accessory	Description	HCV 300	HCV 400	HCV 460	HCV 500	HCV 700	HCH 5	HCH 8	RCV 320	HCC 2	HCC 260 P1	HCC 360 E1
	096978	Silencer Box The HCV 400-460 Silencer Box reduces fan and air flow noise before it is carried into the duct system.		●	●								



HCV 400-460 with Silencer Box

Key features

- Discreet design with same width, depth and colour as HCV 400-460 unit
- Significant sound attenuation is achieved on all four ducts
- Plug-and-Play solution that fits direct to the top of the HCV 400-460 unit
- All four ducts in the Silencer Box are thermally and acoustically insulated and prepared for HCV 400-460 left and right configuration of duct work to reduce installation time
- Easy cabling at the top of the HCV 400-460 unit, because the front lid of the silencer can be removed
- Pressure loss is negligible
- Includes circular sound attenuators made of perforated aluminium surrounded with glass wool insulation and a PE vapour barrier

Dimensions

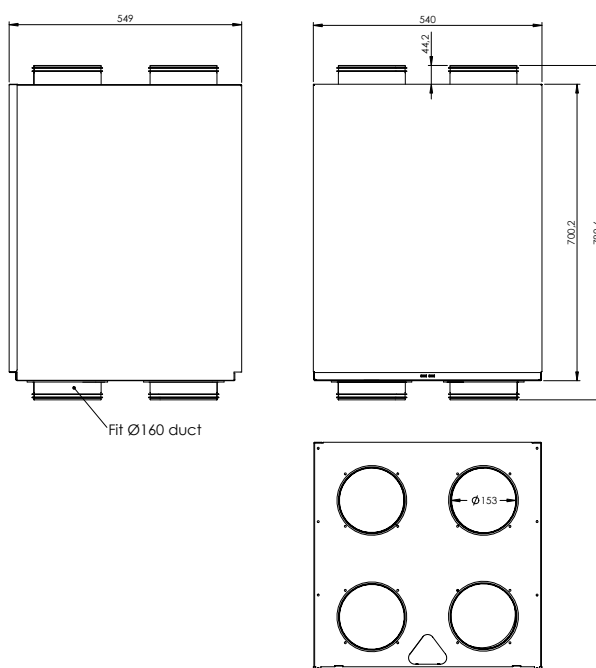

The HCV 400-460 Silencer Box significantly reduces fan and air flow noise. The tables below illustrate the sound data with the Silencer Box installed, and can be compared with the sound data tables of the respective products in the wall-mounted units section of this catalogue.

HCV 400P1 Sound data with G4/G4 filters and silencer box

Air flow	Pressure	Operational point	Sound effect Lw for centre frequency (1/1 octave)								Total sound power Lw(A)	Sound pressure 1m distance	Sound pressure 2m distance
			63Hz	125Hz	250Hz	500Hz	1000Hz	2000Hz	4000Hz	8000Hz			
m ³ /h	Pa		dB								dB(A)		
130	70	Supply	18.3	31.4	33.4	29.5	17.8	12.1	13.7	4.8	36.7		
		Extract	33.8	35.1	33.1	30.1	21.6	17.6	17.0	9.1	39.5		
		Outdoor	33.8	35.1	33.1	30.1	21.6	17.6	17.0	9.1	39.5		
		Exhaust	18.3	31.4	33.4	29.5	17.8	12.1	13.7	4.8	36.7		
		Cabinet										36.2	35.2
150	70	Supply	20.3	32.4	35.4	31.5	18.8	13.1	15.7	6.8	38.4		
		Extract	34.8	35.1	38.1	32.1	22.6	18.6	18.0	10.1	41.7		
		Outdoor	34.8	35.1	38.1	32.1	22.6	18.6	18.0	10.1	41.7		
		Exhaust	20.3	32.4	35.4	31.5	18.8	13.1	15.7	6.8	38.4		
		Cabinet										38.1	36.2
150	100	Supply	21.3	34.4	36.4	32.5	21.8	16.1	19.7	10.8	39.7		
		Extract	37.8	37.1	39.1	34.1	25.6	21.6	23.0	16.1	43.5		
		Outdoor	37.8	37.1	39.1	34.1	25.6	21.6	23.0	16.1	43.5		
		Exhaust	21.3	34.4	36.4	32.5	21.8	16.1	19.7	10.8	39.7		
		Cabinet										41.1	38.1
225	70	Supply	23.3	35.4	35.4	33.5	23.8	17.1	21.7	12.8	39.9		
		Extract	37.8	38.1	39.1	34.1	26.6	22.6	24.0	18.1	43.8		
		Outdoor	37.8	38.1	39.1	34.1	26.6	22.6	24.0	18.1	43.8		
		Exhaust	23.3	35.4	35.4	33.5	23.8	17.1	21.7	12.8	39.9		
		Cabinet										41.8	39.3
225	100	Supply	26.3	39.4	40.4	35.5	25.8	20.1	23.7	15.8	43.9		
		Extract	39.8	41.1	44.1	37.1	29.6	24.6	27.0	22.1	47.4		
		Outdoor	39.8	41.1	44.1	37.1	29.6	24.6	27.0	22.1	47.4		
		Exhaust	26.3	39.4	40.4	35.5	25.8	20.1	23.7	15.8	43.9		
		Cabinet										43.5	41.2
300	100	Supply	28.3	40.4	39.4	40.5	29.8	23.1	27.7	19.8	45.2		
		Extract	42.8	43.1	44.1	41.1	32.6	28.6	31.0	27.1	49.2		
		Outdoor	42.8	43.1	44.1	41.1	32.6	28.6	31.0	27.1	49.2		
		Exhaust	28.3	40.4	39.4	40.5	29.8	23.1	27.7	19.8	45.2		
		Cabinet										46.5	44.5

HCV 400P2 Sound data with G4/G4 filters and silencer box

Air flow	Pressure	Operational point	Sound effect Lw for centre frequency (1/1 octave)								Total sound power Lw(A)	Sound pressure 1m distance	Sound pressure 2m distance
			63Hz	125Hz	250Hz	500Hz	1000Hz	2000Hz	4000Hz	8000Hz			
m ³ /h	Pa		dB								dB(A)		
100	80	Supply	19.4	36.7	25.0	21.6	11.7	4.8	17.6	8.5	37.2		
		Extract	32.9	39.1	24.6	25.7	13.7	9.4	18.2	16.5	40.4		
		Outdoor	32.9	39.1	24.6	25.7	13.7	9.4	18.2	16.5	40.4		
		Exhaust	19.4	36.7	25.0	21.6	11.7	4.8	17.6	8.5	37.2		
		Cabinet										33.4	31.2
150	100	Supply	27.6	37.3	38.0	32.0	21.3	14.0	18.7	16.5	41.5		
		Extract	40.5	41.3	38.0	36.3	23.0	15.9	19.2	16.5	45.5		
		Outdoor	40.5	41.3	38.0	36.3	23.0	15.9	19.2	16.5	45.5		
		Exhaust	27.6	37.3	38.0	32.0	21.3	14.0	18.7	16.5	41.5		
		Cabinet										40.9	38.3
240	200	Supply	34.0	40.2	47.9	41.8	30.4	22.1	21.2	19.8			
		Extract	47.0	46.9	47.2	44.1	32.5	24.5	24.9	21.0			
		Outdoor	47.0	46.9	47.2	44.1	32.5	24.5	24.9	21.0			
		Exhaust	34.0	40.2	47.9	41.8	30.4	22.1	21.2	19.8			
		Cabinet											

HCV 400E1 Sound data with G4/G4 filters and silencer box

Air flow	Pressure	Operational point	Sound effect Lw for centre frequency (1/1 octave)								Total sound power Lw(A)	Sound pressure 1m distance	Sound pressure 2m distance
			63Hz	125Hz	250Hz	500Hz	1000Hz	2000Hz	4000Hz	8000Hz			
m ³ /h	Pa		dB								dB(A)		
100	80	Supply	17.0	36.2	33.7	26.5	16.9	10.0	16.1	0.0	38.5		
		Extract	35.9	37.3	30.9	30.0	19.7	16.0	16.6	7.9	40.7		
		Outdoor	35.9	37.3	30.9	30.0	19.7	16.0	16.6	7.9	40.7		
		Exhaust	17.0	36.2	33.7	26.5	16.9	10.0	16.1	0.0	38.5		
		Cabinet										33.7	32.8
150	100	Supply	21.8	35.9	39.0	30.5	21.5	13.9	18.3	11.7	41.2		
		Extract	38.8	39.5	42.3	35.9	23.0	17.1	18.7	11.6	45.8		
		Outdoor	38.8	39.5	42.3	35.9	23.0	17.1	18.7	11.6	45.8		
		Exhaust	21.8	35.9	39.0	30.5	21.5	13.9	18.3	11.7	41.2		
		Cabinet										40.7	39
240	200	Supply	30.2	39.0	41.6	39.4	28.9	20.5	20.6	20.7	45.2		
		Extract	41.8	43.5	47.1	41.5	31.0	23.9	22.7	22.8	50.2		
		Outdoor	41.8	43.5	47.1	41.5	31.0	23.9	22.7	22.8	50.2		
		Exhaust	30.2	39.0	41.6	39.4	28.9	20.5	20.6	20.7	45.2		
		Cabinet										48.6	46.5

Filters











Most models use 50mm **G4 cartridge** filters as standard for both supply air and extract air. This will cater to the majority of air cleaning needs. The advantage of compact filters is that they have a considerably larger filter surface area than fibrous filters and small bag filters. The filter thus works for longer and under normal conditions it will not need changing more often than twice a year, equivalent to the filter timer setting.

F7 filters (pollen filters): If necessary, F7 filters are available as accessories, which ensure that allergens do not enter the home through the ventilation system. All filters are available to buy online, including those for out-phased units.

Illustration	Accessory	Description	HCV 300	HCV 400	HCV 460	HCV 500	HCV 700	HCH 5	HCH 8	RCV 320	HCC 2	HCC 260P1	HCC 360E1	HCC 360P2	RCC 220
	093844	HCV 300 – Panel filter set, F7/G4 One F7 filter and one G4 filter.	●												
	093845	HCV 300 – Panel filter set, G4 Two G4 filters.	●												
	098346	HCV 400 – Panel filter set, F7/G4 One F7 filter and one G4 filter.		●	●										
	098347	HCV 400 – Panel filter set, G4 Two G4 filters.		●	●										
	096393	HCV 500 – Panel filter set, F7/G4 One F7 filter and one G4 filter.				●									
	087342	HCV 500 – Panel filter set, G4 Two G4 filters.				●									
	093479	HCV 700 – Panel filter set, F7/G4 One F7 filter and one G4 filter.					●								
	093478	HCV 700 – Panel filter set, G4 Two G4 filters.					●								
	063448	HCH 5 – Panel filter set, F7/G4 One F7 filter and one G4 filter.						●							
	063470	HCH 5 – Panel filter set, G4 Two G4 filters.						●							
	063449	HCH 8 – Panel filter set, F7/G4 One F7 filter and one G4 filter.							●						
	063471	HCH 8 – Panel filter set, G4 Two G4 filters.							●						
	087998	HCC 2 – Panel filter set, F7/G4 One F7 filter and one G4 filter.									●	●	●	●	
	087997	HCC 2 – Panel filter set, G4 Two G4 filters.									●	●	●	●	
	111174	RCV 320 – Panel filter set, G4 Two G4 filters.								●					
	111175	RCV 320 – Panel filter set, F7/G4 One F7 filter and one G4 filter.								●					
	30101544	RCC – Panel filter set, G4 Two G4 filters.													●
	30101547	RCC – Panel filter set, F7/G4 One F7 filter and one G4 filter.													●

Pre/after water heating coils

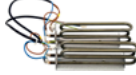
Pre- and after-heating coils are effective solutions to regulate the air temperature, with preheating coils an excellent choice for preventing ice building up in the heat exchanger at low temperatures, and post-heating coils effective at increasing the supply air temperature.

Illustration	Accessory	Description	HCV 300	HCV 400	HCV 460	HCV 500	HCV 700	HCH 5	HCH 8	RCV 320 P1	RCV 320 P2	HCC 2	HCC 260 P1	HCC 360 E1	HCC360	RCC 220
	063843	Water heating coil set, Ø125mm The set includes water heating coils with 2RR, two-way water valve, 0-10V servo motor, 230/24V VAC trafo, duct sensor and tube sensor for frost protection. To be controlled by the accessory control HAC.	●							●	●	●	●	●	●	●
 Servo motor	063851	Water heating coil set, Ø160mm The set includes water heating coils with 2RR, two-way water valve, 0-10V servo motor, 230/24V VAC trafo, duct sensor and tube sensor for frost protection. To be controlled by the accessory control HAC.		●	●	●		●		●	●	●	●	●	●	●
 Two-way water valve	063852	Water heating coil set, Ø250mm The set includes water heating coils with 2RR, two-way water valve, 0-10V servo motor, 230/24V VAC trafo, duct sensor and tube sensor for frost protection. To be controlled by the accessory control HAC.					●		●							
 230/24 V VAC trafo																
	076107	Preheating coil, 700W For building into the unit.	●													
	098268	Preheating coil, 1400W For building into the unit.		●												
	108639	Preheating coil, 1850W For building into the unit.			●											
	115124	Preheating coil, 1400W For building into the unit.				●		●								
	076108	Preheating coil, 2 x 600W For building into the unit.				●										
	076109	Preheating coil, 2 x 800W For building into the unit.					●									
	110459	Preheating coil, 1 x 900W For building into the unit, only for the RCV320P2. RCV320 P1 use external preheater									●					

Pre/after water heating coils



Water heating coils

The water heating coil kit includes 2RR, 2-way water valve, 0-10V servo motor, 230/24VAC trafo, duct sensor and tube sensor for frost protection. It is controlled by the accessory control HAC 2.

CWW 125-2-2.5		Max capacity						Supply air temperature 21°C					
		80°C/60°C			60°C/40°C			80°C/60°C			60°C/40°C		
Air volume	m ³ /h	85	150	215	85	150	215	85	150	215	85	150	215
Air temperature out	°C	40	36	34	28	25	23	21	21	21	21	21	21
Pressure loss	Pa	11	28	51	11	28	51	11	28	51	11	28	51
Capacity	kW	0.7	1.1	1.4	0.4	0.5	0.6	0.2	0.3	0.5	0.2	0.3	0.5
Water flow	L/h	36	36	72	36	36	36	9	10	23	17	22	28
Pressure loss, max.	KPa	0.5	0.5	1	0.5	0.5	0.5	0.2	0.2	0.4	0.3	0.4	0.5

CWW 160-2-2.5**		Max capacity						Supply air temperature 21°C					
		80°C/60°C			60°C/40°C			80°C/60°C			60°C/40°C		
Air volume	m ³ /h	145	250	335	145	250	335	145	250	335	145	250	335
Air temperature out	°C	47	43	40	33	31	29	21	21	21	21	21	21
Pressure loss	Pa	6	15	27	6	15	27	6	15	27	6	15	27
Capacity	kW	1.6	2.4	3.0	0.9	1.3	1.7	0.3	0.5	0.7	0.3	0.5	0.7
Water flow	L/h	72	108	144	36	72	72	14	24	35	12	28	30
Pressure loss, max.	KPa	1	3	4	0.5	1	2	0.2	0.4	0.5	0.1	0.4	0.5

CWW 250-2-2.5***		Max capacity						Supply air temperature 21°C			
		80°C/60°C		60°C/40°C		80°C/60°C		60°C/40°C			
Air volume	m ³ /h	360	630	630	360	360	630	360	630		
Air temperature out	°C	44	40	31	29	21	21	21	21		
Pressure loss	Pa	10	25	10	25	10	25	10	25		
Capacity	kW	3.6	5.3	2.0	3.0	0.74	1.29	0.74	1.28		
Water flow	L/h	72144	252	108	144	30	61	40	61		
Pressure loss, max.	KPa	1	3	1	2	0.5	1.0	0.7	1.0		

*Air in 15°C.

** Please note that this heater coil has 160mm duct connections, so 2 pcs of Ø160/200mm duct reduction parts are needed for installation with a HCV 700 (Ø200).

*** Please note that this heater coil has 250mm duct connections, so 2 pcs of Ø200/250mm duct reduction parts are needed for installation with a HCV 700 (Ø200).

Pre/after water heating coils







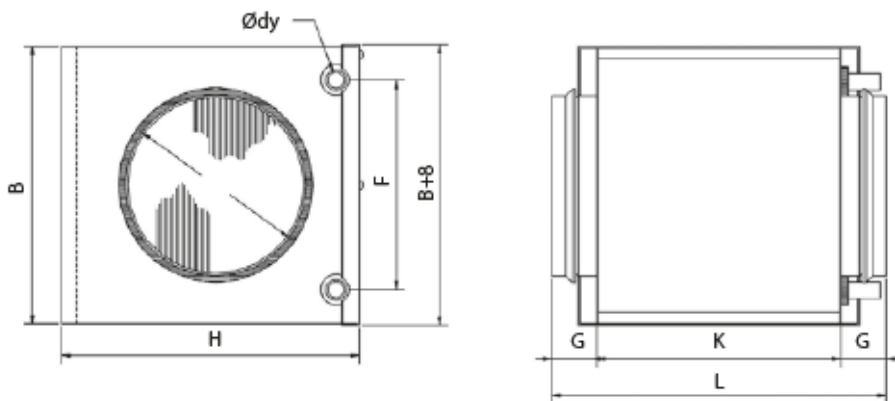

Weight

	Ød	B	H	Ødy	F	G	K	L	Weight
	mm								kg
CWW 125-2-2.5	125	238	180	10	137	40	276	356	3.5
CWW 160-2-2.5	160	313	255	10	212	40	276	356	5.4
CWW 250-2-2.5	250	398	330	10	250	40	276	356	7.7

Dimensions



Pre/after heaters

Illustration	Accessory	Description	HCV 300	HCV 400	HCV 460	HCV 500	HCV 700	HCH 5	HCH 8	RCV320 P1	RCV320 P2	HCC 2	HCC 260 P1	HCC 360	RCC 220
	063853	Electric pre-/after heating coil, Ø125mm, 900W stand-alone The set includes a 900W electric heater with duct sensor and built-in thermostat control. Direct control by the built-in thermostat, with no connection to the ventilation unit.	▼							▼	▼	▼	▼	▼	●
	063854	Electric pre-/after heating coil, Ø160mm, 1200W stand-alone The set includes a 1200W electric heater with duct sensor and built-in thermostat control. Direct control by the built-in thermostat, with no connection to the ventilation unit.		▼		▼	▼	●							
	063855	Electric pre-/after heating coil, Ø250mm, 1800W stand-alone The set includes a 1800W electric heater with duct sensor and built-in thermostat control. Direct control by the built-in thermostat, with no connection to the ventilation unit.					▼		●						
	063898	Electrical pre-/after heater kit, Ø125mm, 900W, 0-10V controlled The set includes a 900W heater, integrated 0-10V regulation and a duct sensor. Must be controlled from the accessory control HAC.	▼							▼	▼				●
	063899	Electrical pre-/after heater kit, Ø160mm, 1200W, 0-10V controlled The set includes a 1200W heater, integrated 0-10V regulation and a duct sensor. Must be controlled from the accessory control HAC.		▼	▼	▼	▼		●						
	063900	Electrical pre-/after heater kit, Ø250mm, 1800W, 0-10V controlled The set includes a 1800W heater, integrated 0-10V regulation and a duct sensor. Must be controlled from the accessory control HAC.					▼		●						
	086877	External electric preheating coil Ø125, 900W The set includes a 900W heater and a power cable. The heater is controlled and powered by the main PCB at the unit.											●	●	●
		External electric preheating coil Ø125, 1200W The set includes a 1200W heater and a power cable. The heater is controlled and powered by the main PCB at the unit.								●					

▼ Only used for after heating.

Pre/after heaters features



Circular electric duct heater for reheating of supply air

The electric duct heater is designed for installation in the supply air duct. The duct heater is provided with duct connections with a rubber sealing gasket. The duct heater is not suitable for outdoor installation. The control current is connected to the accessory control HAC 2. Connection to supply voltage 230V is made separately. The duct heater is controlled by a stepless regulation via the accessory control HAC 2.

Circular electric duct heater, direct control by the built-in thermostat

This duct heater is controlled by the built-in thermostat. Both heaters are supplied with a duct sensor.

Capacity, dimensions and weight

The duct heaters are without fins and therefore the resulting air pressure loss is negligible.

Specifications	Units	063853	063854	063855
Air volume	m ³ /h	180	300	450
Heat output	kW	0.9	1.2	1.8
Temperature rise	°C	14.7	11.7	11.7
Power consumption, 1 x 230V	A	4.1	5.5	8.2
Duct connection	Ømm	125	160	250
Weight	kg	3.0	3.5	5.0

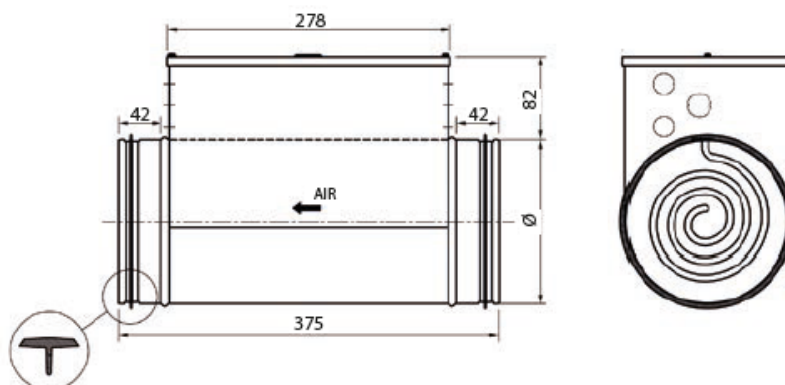

Dimensions



Enthalpy heat exchangers









Heat recovery takes place in a highly efficient counter-flow heat exchanger, which is able to achieve optimum efficiency with the least possible loss of pressure in connection with the low air volumes used in housing. Transferring the humidity from the extract air to the fresh supply air prevents a dry indoor climate during wintertime.

In the summer, when the relative humidity of the outdoor air is high, supply air will be dehumidified when passing through the enthalpy exchanger. This makes the supply air feel comfortably cold. Because of their superb ability to recover both heat and humidity, enthalpy exchangers are known to reduce heating costs substantially.

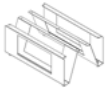











Illustration	Accessory	Description	HCV 300	HCV 400 P1-P2	HCV 460P2	HCV 500	HCV 700	HCH 5	HCH 8	RCV 320P1	RCV 320P2	HCC2	HCC 260P1	HCC 360P2	RCC120/220
	099183-4	Enthalpy heat exchanger For SWOP solution. Separate box including installation, labelling, flow chart etc.		●	●										
	099229	Enthalpy heat exchanger For SWOP solution. Separate box including installation, labelling, flow chart etc.										●	●	●	
	099183-5	Enthalpy heat exchanger For SWOP solution. Separate box including installation, labelling, flow chart etc.								●	●				

When the heat exchanger has been swapped, you need to use the PC Tool to change the unit type to the right enthalpy variant (E1). To ensure correct air balance, you will subsequently have to recalibrate the unit.



Plugs and cables

Illustration	Accessory	Description	HCV 300	HCV 400	HCV 460	HCV 500	HCV 700	HCH 5	HCH 8	RCV 320	RCV 320P1	RCV 320P2	HCC 2	HCC 260 P1	HCC 360	RCC 220
	087353	Condensate pump kit This condensate pump kit is designed for mounting on HCC 2 units where there is no safe drain with fall to a drainage or on units where the drain is too far away. The kit is furnished with a bracket for fixing it to the HCC 2 unit, a power supply cable for connection to the HCC 2 unit, pressure equalisation hose and drain hose.											●			
	108625	Condensate pump kit This condensate pump kit is designed for mounting on HCC 260, HCC 360 & RCC 220 units where there is no safe drain with fall to a drainage or on units where the drain is too far away.												●	●	●
	064885	Power supply, 230VAC - 24VDC for duct control The 24VDC power supply is used together with HAC if the ventilation unit is controlling duct damper motors.	●	●	●	●	●	●	●	●	●	●	●	●	●	●
	086861	Digital plug, 25 pcs This digital plug is connected to the control of the unit. This allows to override the following fan speed, fire/smoke/negative pressure/stop+alarm and high water level stop.	●	●	●	●	●	●	●	●	●	●	●	●	●	●
	087619	USB cable, 3m USB cable to be used in connection with software update of units and Dantherm PC Tool (HPT 1).	●	●	●	●	●	●	●	●	●	●	●	●	●	●
	099104	Cable for HCP 11, 20m Extention cable for the wired HCP 11 control.	●	●	●	●	●	●	●	●	●	●	●	●	●	●
	086853	Calibration set, 10 pcs Calibration set for air flow calibration. Including 3m silicone tube, suction cups and fittings.	●	●	●	●	●	●	●	●	●	●	●	●	●	●
	062737	Siphon trap kit Including 2m 3/4" hose.						●	●							
	064807	Heat cable, 3m 230V, 10W/m including 5°C thermostat. For frost protection of condensate hose.						●	●							

Installation accessories

Illustration	Accessory	Description	HCV 300	HCV 400	HCV 460	HCV 500	HCV 700	HCH 5	HCH 8	RCV 320P1	RCV 320P2	RCC 220	HCC 2	HCC 260 P1	HCC 360
	053730	Floor stand Height 230mm and adjustable feet. RAL 9016 Traffic white.	●												
	099220-2	Floor stand Height 120mm and adjustable feet. RAL 9016 Traffic white.		●	●										
	099220-3	Floor stand Galvanised metal surface		●	●										
	052423	Floor stand Height 230mm and adjustable feet. RAL 9016 Traffic white.				●	●								
	111172	Floor stand Floor stand RCV, Galvanised metal surface								●	●				
	098251	Mounting attrap, 2 sets To indicate the mounting dimensions in advance, without using the real unit. Includes 2 x mounting attrap + 2 x wall rails.		●	●										
	098426	Mounting attrap To indicate the mounting dimensions in advance, without using the real unit. Includes 2 x mounting attrap + 2 x wall rails.	●												
	052250	Inspection door 730 x 1200mm Mat white RAL 9016 with key.										●	●	●	●
	052251	Inspection door with sound insulation 730 x 1200mm Mat white RAL 9016 with key.										●	●	●	●
	052252	Inspection door 730 x 1500mm Mat white RAL 9016 with key.										●	●	●	●
	052254	Inspection door with sound insulation 730 x 1500mm Mat white RAL 9016 with key.										●	●	●	●
	111176	Oval duct adaptor PE-HD adaptor to connect an oval duct. The integrated lip seal provides an airtight connection between the pipe and the adaptor. The oval duct adaptor is suitable for supply air.								●	●				

Display kits

Illustration	Accessory	Description	HCV 300	HCV 400	HCV 460	HCV 500	HCV 700	HCH 5	HCH 8	RCV 320P1	RCV 320P2	HCC 2	HCC 260 P1	HCC 360	RCC 220
	051958	Display kit Kit including polycarbonate and mounting parts, flow chart and instructions.		●	●										
	051956	Display kit Kit including polycarbonate and mounting parts, flow chart and instructions.										●	●	●	
	111173	Display kit Kit including polycarbonate front.								●	●				

HCV and HCC units have an embedded control which measures and adjusts all parameters continuously in order to maintain a correct ventilation level at the lowest possible energy consumption. The controller has a wide range of connections for both internal and external accessories.

**PLATFORM 2**

The controller has a wide range of connections for both internal and external accessories.

For external connections, you will find:

- Wired LAN interface that supplies data communication to ModBus over TCP/IP
- Ideal for connection to external building management systems (BMS/CTS)
- ModBus over RS485: For HAC accessory control or wired control (HCP 11)
- Antenna socket for the wireless remote control antenna
- Two additional digital inputs that can be used for e.g. forced operation controlled by the hygrostat, cooker hood, fire protection or similarly

For more on internal accessories, please see the "Accessories" chapter.

The USB connection of the controller enables professional installers to carry out all adjustments and settings using the Dantherm PC Tool. The PC Tool is also capable of displaying both live and historic data for all unit components. This is crucially important in connection with maintenance, service and troubleshooting.

The USB port offers firmware update option.

The HCV units are secured against incorrect and uneconomical operation for long periods of time. Several of the functions return to default after four hours as a means of preventing excessive energy consumption, for instance if a unit is left running at maximum fan speed or in manual by-pass mode. If you switch off the installation, it will automatically restart after four hours to ensure proper ventilation and to keep condensation from forming in the ducts and in the unit.

In emergency situations where there is a warning message about switching off ventilation systems and closing doors and windows, the supply current to the system must be interrupted by a safety switch or similarly.

Control panel

The HCV unit has a built-in control panel with four buttons for controls, and nine LED feedback signals.

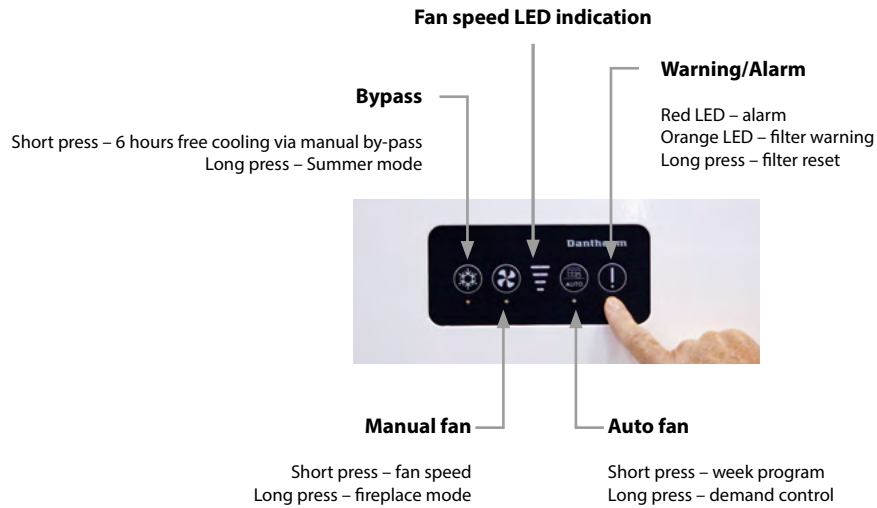

Fan control

During initial calibration, fan speed no. 3 is set on the control panel to the nominal air volume the house requires under normal usage.

The correlation between the four fan speeds on the control panel is as follows:

- Fan speed 0 = both fans stopped for 4 hours
- Fan speed 1 = 30% lower than fan speed 2
- Fan speed 2 = 30% lower than fan speed 3
- Fan speed 3 = nominal air change, set by installer during the initial calibration
- Fan speed 4 = 30% higher than fan speed 3 (4-hour time-out)

In demand-controlled mode with integrated humidity sensor, the maximum speed is step 3.

In demand-controlled mode with integrated VOC sensor or CO₂ sensor connected to the HAC 2, the maximum speed is step 3.

Filter control

The filter pressure is expected to increase between filter change intervals. To compensate for the reduced air volumes over time, the two fans run faster and faster until the filter alarm is triggered and the filter timer has been reset.

WIRELESS REMOTE CONTROL



We offer a wireless remote control option, which can be mounted on the wall or placed on a shelf. The remote control is designed for the user, but also includes a special installer menu, allowing the installer to do extensive settings without the use of the PC Tool.

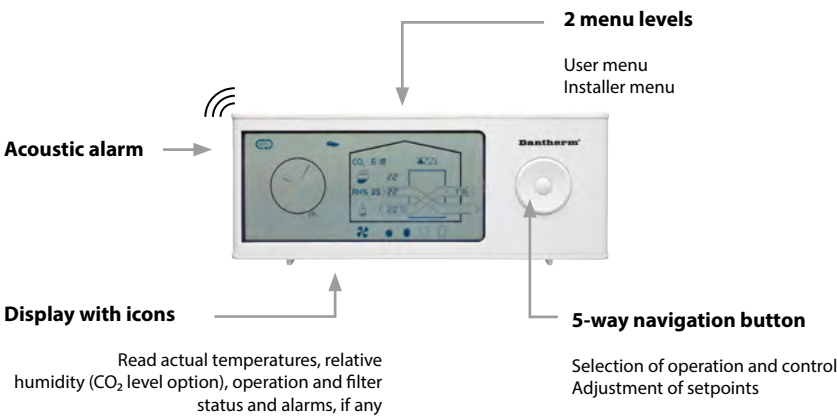

The user features are:

- Select fan speed in manual mode
- Select demand mode
- Select week mode, as well as selecting week program 1-11
- Manually activated by-pass
- Enable fireplace boost mode – seven minutes with overpressure inside the house for easy ignition of a fireplace
- Enable/disable away mode – the unit decreases permanently to fan speed 1
- Enable/disable night mode – the unit decreases to fan speed 1. The hour for enable/disable can be adjusted.
- Adjust filter timer duration
- Reset filter timer after filter exchange
- Reading air temperatures in the duct connections, including the remote controls embedded temperature sensor
- Setting time and date

The remote control has a visual/acoustic alarm that will sound when the filter needs to be inspected or replaced. This ensures correct maintenance even when the unit is set to demand mode and your attention is not at the remote control.

The wireless remote control uses two AAA alkaline batteries. Battery lifetime of up to two years is possible, as the display and remote shifts to hibernation mode after two minutes without user interaction. In addition, the remote is shut down at night.

Illustration	Code	Description	HCV 300	HCV 400	HCV 460	HCV 500	HCV 700	RCV 320P1	RCV 320P2	RCC 220	HCH 5	HCH 8	HCC 2	HCC 260 P1	HCC 360
	087953	Wireless remote control, HRC 3 Remote control with manual operation, demand-controlled operation, week program, away operation, night operation, readings and installer menu.	●	●	●	●	●	●	●	●	●	●	●	●	●

WIRED CONTROL



Wired control (HCP)

This wired control comes with a white plastic frame and a metal frame for fastening into a standard junction box as well as a 6m communication cable. Alternatively, Dantherm can supply a box for fixing to the wall in an appropriate place.

The HCP 11 wired control gives the user the following possibilities :

- Manual control of air change (step 0-4)
- Control of air change with week program
- Demand controlled air change (when RH and VOC sensors are connected)
- Enable summer cooling mode (only extract air)
- Enable free cooling with by-pass
- Enable fireplace mode
- Reading and resetting of alarms, including filter alarm

The installer can use the wired HCP 11 to adjust air volumes during commissioning.

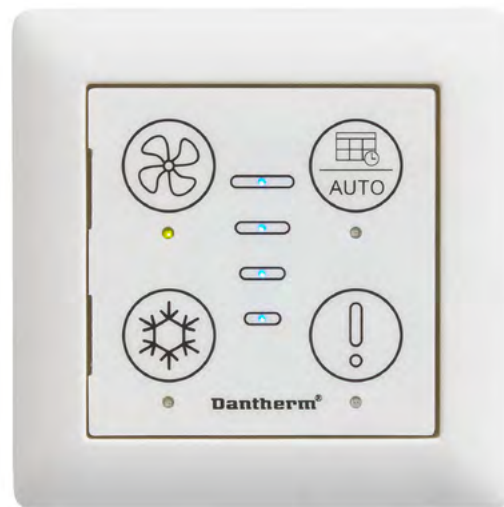

Illustration	Code	Description	HCV 300	HCV 400	HCV 460	HCV 500	HCV 700	RCV 320P1	RCV 320P2	RCC 220	HCH 5	HCH 8	HCC 2	HCC 260 P1	HCC 360
	052539	Wired control, HCP 11 With acoustic alarm. Fire protection control compatible. Wired control with manual control, week program, demand control, summer cooling mode, free cooling with by-pass, fireplace mode as well as air flow settings. Including 6m cable.	●	●	●	●	●	●	●	●	●	●	●	●	●

DANTHERM APP

The Dantherm App, which is available for iOS and Android via the App store and Google play, offers a user-friendly and intuitive way to control the residential ventilation unit. The App is connected to the Wi-Fi router of the house. It is available for all HCV and HCC units.

The control options include:

- Demand control operation
- Manual operation
- Week program operation
- Night operation
- Manual by-pass cooling
- Summer cooling.
- Fireplace mode
- Alarms
- Settings menu

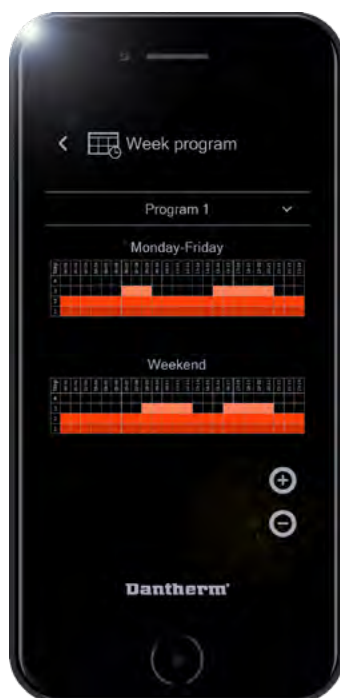

Easy to use! You can download it on Google Play or the App Store. Demo mode included.



CONTROL ACCESSORIES RANGE

A wide range of additional control accessories are available in order to cover any specific need for control and system optimisation.

Illustration	Accessory	Description	W	HCV 400	HCV 460	HCV 500	HCV 700	HCH5	HCH8	RCC 220	HCC 2	HCC 260 P1	HCC 360
	516301	Hygrostat The hygrostat measures the humidity in wet rooms. Ideal for high-humidity rooms requiring an increased air change, for instance bathrooms.	●	●	●	●	●	●	●	●	●	●	●
	113118-2	Humidity sensor, 700mm The RH% demand sensor will continuously monitor the humidity of the extract air and adjust the air flow level accordingly.									●	●	●
	111635-2	Air quality sensor, 700mm The VOC sensor will continuously monitor the level of artificial as well as natural organic fumes in the air and adjust the air flow level accordingly.									●	●	●
	113114-2	Humidity sensor, 480mm The RH% demand sensor will continuously monitor the humidity of the extract air and adjust the air flow level accordingly.	●	●	●	●	●	●	●	●			
	111633-2	Air quality sensor, 480mm The VOC sensor will continuously monitor the level of artificial as well as natural organic fumes in the air and adjust the air flow level accordingly.	●	●	●	●	●	●	●	●			
	063874	CO₂ sensor For control of air change accordance with the CO ₂ level in a given room.	●	●	●	●	●	●	●	●	●	●	●
	096984	Antenna extender 5m.		●	●					●			
	098084	Potentialfree Damper Controller (PDC) For potential free ON/OFF control of damper motor. Up to 4 PDC per ventilation unit.	●	●	●	●	●	●	●	●	●	●	●
	098083	Fire Protection Controller (FPC) For connection of fire and smoke damper or smoke damper. Up to 4 FPC per ventilation unit.	●	●	●	●	●	●	●	●	●	●	●
	077138	Accessory control, HAC 2 For control of heating coils, geothermal pre-cooling/heating coils, duct dampers, stop function input, fire thermostat, CO ₂ sensor, hygrostat and alarms. Including 3m cable.	●	●	●	●	●	●	●	●	●	●	●



Accessory control HAC 2

Accessory control HAC 2

One or more of the following functions can be connected to the accessory control:

- After heating coils for water or electricity
- Geothermal preheating/pre-cooling coils
- 24 VDC duct damper outlet
- Stop function inlet
- Fire/smoke detector inlet
- External CO₂ sensor for demand control
- External hygrostat
- Filter alarm outlet
- General alarm

HAC 2 comes with 3m cable.



VOC air quality demand sensor

VOC air quality demand sensors

The unit can be fitted with a VOC air quality sensor. This sensor will continuously monitor the level of artificial as well as natural organic fumes in the air.

Examples of included fumes:

- Natural fumes, e.g. formaldehyde from building materials
- Chemical fumes from sprays, e.g. hair spray or perfumes
- Indoor pollution e.g. from smoking and printing with laser printer
- Fumes from fire-retardant substances in carpets, paint and furniture

Using the VOC sensor in demand mode will result in the correct level of ventilation with the lowest possible power consumption. If a wireless remote control or App is connected, the actual VOC level will be shown in the display using a 3 level icon.



Humidity sensor

Humidity RH% demand sensor

The ventilation units can be fitted with a humidity sensor (RH%). This sensor will continuously monitor the humidity of the extract air and adjust the air flow level in accordance with the demand of the home. Using demand mode will ensure the correct level of ventilation at the lowest possible electrical power consumption. The level of humidity is indicated in the Dantherm App as well as the wireless remote control (if connected). If VOC, CO₂ and RH% sensors have been fitted, the ventilation level will be determined by the sensor that detects the highest demand.

FIRE PROTECTION CONTROLLER (FPC)

The Fire Protection Controller (FPC) is a unit that controls a fire damper for fire and smoke protection purposes. The unit has been designed for Belimo or similar fire damper actuators fitted with spring-return and position feedback. The fire damper actuator is connected directly to the FPC, and then controlled via the ventilation system. Each FPC is to be addressed individually. Up to four FPCs can be connected to one ventilation unit.

The FPC is fitted with LED lamps indicating the damper position and status, and a digital input socket for surveillance if so required in your installation, for instance for a thermostat or a smoke detector.



Features

- Easy cable installation
- Individual alarm and damper status
- Digital input for thermostat or smoke detector for surveillance where required
- LED lamps indicate damper position and status
- Weekly or monthly self-test

FIRE PROTECTION CONTROLLER (FPC)

For decentralised ventilation applications, the most frequently used solution is to lead exhaust air from each apartment and to the roof through separate air ducts. The ducts are fireproofed and joined in one exhaust air cowl. Such a solution often requires more ventilation shaft space than available, particularly in connection with renovation projects. Instead, the exhaust air can be removed using one joint air duct. But that requires fire and smoke dampers, fire thermostats and external automatic fire protection. Until now, this has dramatically increased the price of renovation projects.

Keeping installation costs for projects with joint air ducts at a very competitive level, Dantherm's new residential ventilation units have been fully prepared for control of fire and smoke dampers by means of the FPC.

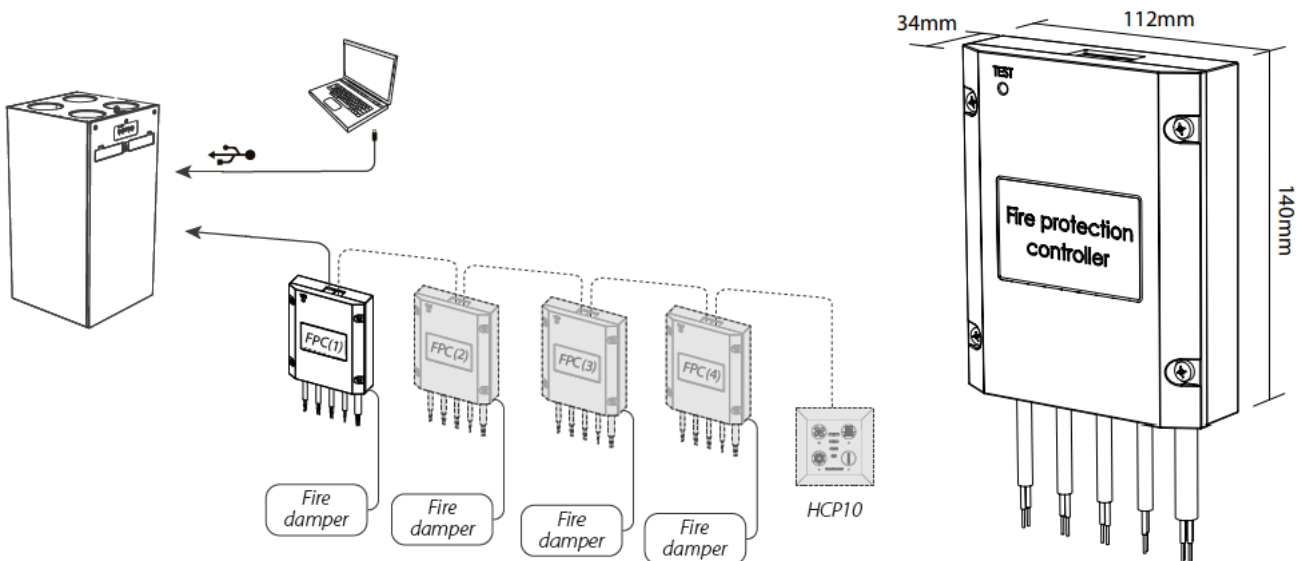

FIRE PROTECTION CONTROLLER SET-UP

The ventilation unit controls the FPC which in turn controls the fire and smoke dampers by means of the connected fire thermostats and smoke sensors. When a fire is detected, the ventilation unit is shut down and the fire and smoke dampers are closed. That stops smoke from spreading to other apartments. The ventilation keeps running in apartments where there is no fire.

Fire control features:

Activation of the digital input, for instance if fire or smoke is detected

- The ventilation unit is shut down
- The fire and smoke damper is closed

Loss of power or stopped ventilation unit

- The fire and smoke damper is closed

Faulty components, wiring and bus communication

- The ventilation unit is shut down
- The fire and smoke damper is closed
- The ventilation unit displays an FPC error and logs it in the alarm log

Weekly or monthly self-test

- Shuts down the ventilation unit, closes the fire and smoke damper and tests the position feedback
- Opens the fire and smoke damper, tests the position feedback and powers up the ventilation unit
- If faults are registered, the fire damper is closed, the ventilation unit is shut down and the display will report an error which will be registered in the alarm log

Manual test activated using the PC Tool in connection with

- Annual testing of automatic control as well as fire and smoke dampers
- Testing before apartment occupancy

After faults, the ventilation units must be reset manually using the control panel. Automatic and manual tests are registered in the alarm log of the unit.

Power	Unit	Connection
Damper motor supply	24V/230V AC	Terminal 1&2 Wago cage clamp
Position feedback Digital input for dry contact use SPDT connections for open/close feedback	12V/12mA	Terminal S1-S6 Wago cage clamp
Thermostat/smoke detector For dry contact use	12V/12mA	Terminal 10-11 Wago cage clamp
RS 485 communication ModBus RTU protocol	12V/A-B	RJ11 696C
Power consumption		Max 100mA

DANTHERMGROUP

DENMARK

Dantherm Denmark A/S
DK-7800 Skive
+45 96 14 37 00
sales.dk@danthermgroup.com

GERMANY

Trotec GmbH
52525 Heinsberg
+49 2452 962-0
vertrieb.de@danthermgroup.com

FRANCE

Dantherm Group SAS
69694 Vénissieux Cedex
+33 4 78 47 11 11

67850 Herrlisheim
+33 3 90 29 48 18
sales.fr@danthermgroup.com

SPAIN

Dantherm Group SP SAU
28108 Alcobendas, Madrid
+34 91 661 45 00

46980 Paterna, Valencia
+34 961 524 866
sales.es@danthermgroup.com

UNITED KINGDOM

Dantherm Group Ltd
Maldon CM9 4XD
+44 (0)1621 856611
sales.uk@danthermgroup.com

ITALY

Dantherm Group S.p.A.
37010 Pastrengo (VR)
+39 045 6770533
sales.it@danthermgroup.com

POLAND

Dantherm Group Sp. z o.o.
62-023 Gądki
+48 61 65 44 000
sales.pl@danthermgroup.com

NORWAY

Dantherm Group AS
3138 Skallestad
+47 33 35 16 00
sales.no@danthermgroup.com

SWEDEN

Dantherm Group AB
602 13 Norrköping
+46 (0)11 19 30 40
sales.se@danthermgroup.com

SWITZERLAND

Dantherm Group AG
CH-5405 Baden Dättwil
+41 43 500 00 50
sales.ch@danthermgroup.com

Sales contact:

02-2025

KEEP UPDATED
FOLLOW US ON:



danthermgroup.com